

R454b Refrigerant

SUBMITTAL DATA SHEET



Series Name: Extreme Heat AHU Series
Model Number: MAUSE-H36B-2A/MO1SE-H36B-2A

Air Handler Heat Pump System

Location:	Approval:
Engineer:	Date:
Submitted to:	Construction:
Submitted by:	Unit #:
Reference:	Drawing #:



INDOOR SPECIFICATION

ESP(inWG)	0~1.0	
Indoor Air Flow (Turbo/H/ML/Si) (CFM)	1236 / 1148 / 1059 / 971 / 971	
Indoor Noise Level (Turbo/H/ML/Si) (dBA)	48 / 46.5 / 45 / 33 / 33	
Dimension (W×D×H)	inch	17-1/2 x 21-1/2 x 58-1/8
	mm	445 x 546 x 1476
Package (W×D×H)	inch	20-1/2 x 31-1/8 x 62-3/8
	mm	520 x 790 x 1585
Net/Gross Weight	lbs	149 / 182
	kg	67.7 / 82.6

OUTDOOR SPECIFICATION

Compressor Type	TWIN-ROTARY	
Compressor Model	EKPQ420D1UMUA	
Refrigerant	R454B	
Refrigerant Oil Charge(mL)	1,460	
Refrigerant Oil	VG75	
Outdoor Air Flow (Max) (CFM)	3,002	
Outdoor Noise Level (dBA)	63	
Dimension (W×D×H)	inch	38-9/16 x 16-3/8 x 38-3/8
	mm	980 x 415 x 975
Package (W×D×H)	inch	45-1/16 x 19-11/16 x 42-1/2
	mm	1145 x 500 x 1080
Net/Gross Weight	lbs	204 / 235
	kg	92.6 / 106.7

EFFICIENCY

Cooling		Heating	
SEER2	18.0	HSPF2-4	10.0
EER2	12.0	COP	3.50

PERFORMANCE of Cooling

Cooling (Btu/hr)	
Rated Capacity	36,000
Min/Max Capacity	12,100 ~ 43,000
Moisture Removal(L/h)	3.41
Standard Operating Range(°F/°C)	-22~122 (-30 ~ 50)
Rated Cooling Conditions:	Indoor: 80°F DB/67°F WB Outdoor: 95°F DB/75°F WB

PERFORMANCE of Heating

Heating (Btu/hr)	
1. @ 47°F Rated	37,000
2. @ 47°F Min/Max Capacity	11,400 ~ 47,000
3. @ 17°F Rated	31,000
4. @ 5°F Rated: Capacity / COP	37,400 / 1.9
5. @ 5°F Max: Capacity	37,400
Standard Operating Range(°F/°C)	-22~75 (-30 ~ 24)
1. Rated Heating Conditions:	Indoor: 70°F DB/60°F WB Outdoor: 47°F DB/43°F WB
2. Rated Heating Conditions:	Indoor: 70°F DB/60°F WB Outdoor: 17°F DB/15°F WB
3. Heating Conditions, Compressor Operating at Max. Frequency	Indoor: 70°F DB/60°F WB Outdoor: 5°F DB/5°F WB

ELECTRICAL

Indoor Power Supply	115/208/230V,60Hz,1Ph	
Indoor MCA 115V/(208/230V)	8.0/6.0	
Indoor MOP	15.0	
Outdoor Power Supply	208/230V,60Hz,1Ph	
Outdoor MCA	29.0	
Outdoor MOP	30.0	
Communication Wiring	AWG 20/2	
Compressor RLA	20.5	
Outdoor Fan Motor RLA	2.4	
Outdoor Fan Motor W	250	
Indoor Fan Motor RLA	4.5	
Indoor Fan Motor W	600	
System Power Input @ Cooling (W)	3,000 (910 ~ 4,370)	
System Power Input @ Heating (W)	3,100 (755 ~ 4,210)	
MCA: Min. circuit amps (A)	MOCP: Max. over current protection (A)	
RLA: Rated load amps (A)	W: Fan motor rated output (W)	

PIPING

Throttle type(Indoor)	EXV
Throttle type(Outdoor)	EXV
Liquid Size	3/8" (9.52mm)
Gas Size	3/4" (19mm)
Max. Piping Length(ft/m)	246 (75)
Max. Height Difference(ft/m)	98 (30)
Max. Pre-charged Length(ft/m)	25 (7.5)
Refrigerant Pre-charged Amount(oz/kg)	127 (3.6)
Additional Charge of Refrigerant(oz/ft)/(g/m)	0.7 (65)
Connection Method	Flared

Indoor Unit Dimension

Unit: inch (mm)

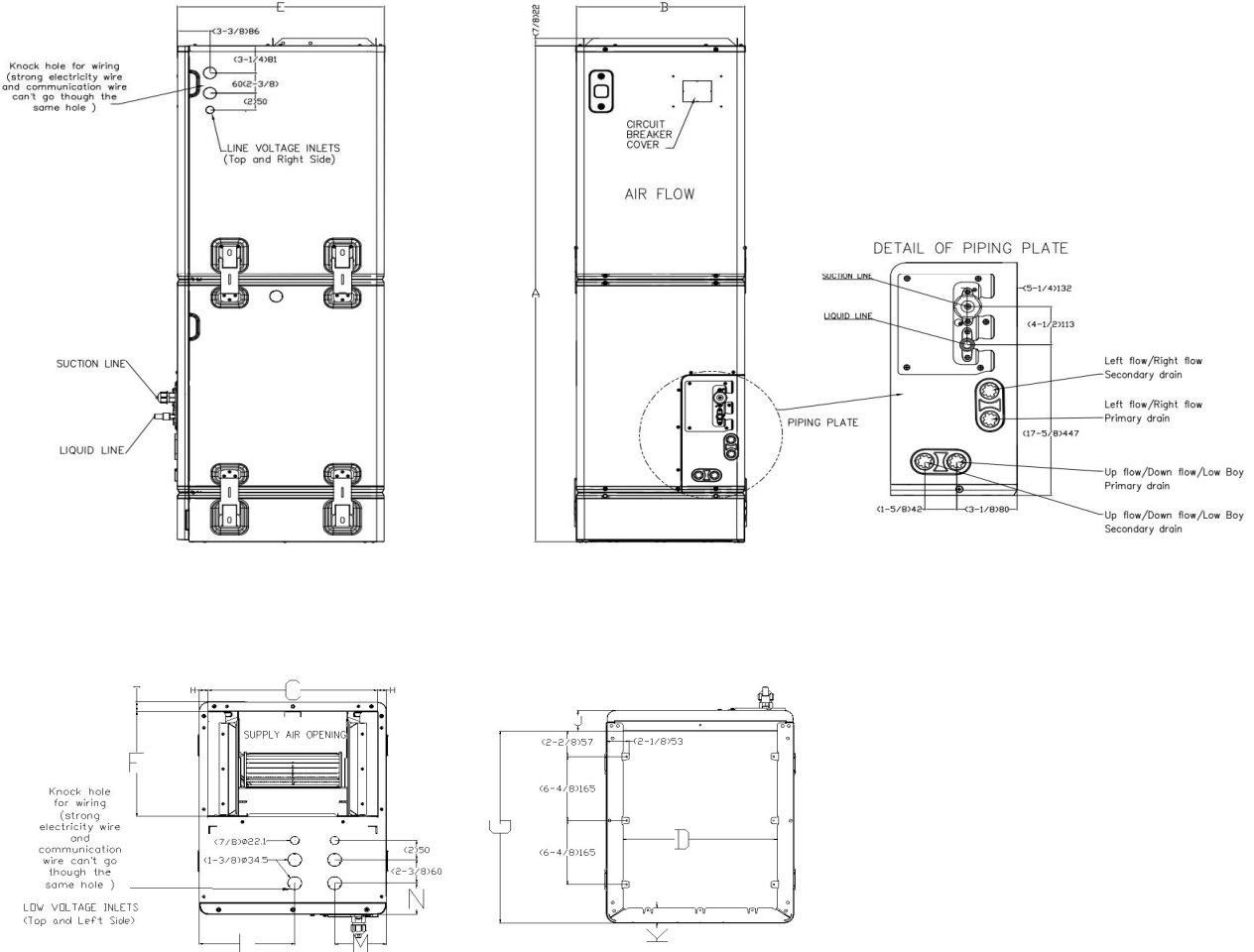

Dimensions	Model(Btu/h)	18K/24K		30K/36K		48K/54K	
		inch	mm	inch	mm	inch	mm
A	Model Height	53-7/8	1368	58-1/8	1476	60-1/8	1526
B	Model Width	14-4/8	368	17-4/8	445	21-4/8	546
C	Supply Air Opening Width	12-7/8	328	16	405	19-7/8	506
D	Return Air Opening Width	11-1/8	282	14-4/8	368	18-4/8	470
E	Model Depth	21-1/2	546	21-1/2	546	21-1/2	546
F	Supply Air Opening Depth	10-5/8	271	10-5/8	271	10-5/8	271
G	Return Air Opening Depth	19	484	19	484	19	484
H	Supply Air Opening Clearance	7/8	22	7/8	22	7/8	22
I	Return Air Opening Clearance	1	24	1	24	1	24
J	Return Air Opening Front Clearance	2-4/8	62	2-4/8	62	2-4/8	62
K	Return Air Opening Back Clearance	1-4/8	37	1-4/8	37	1-4/8	37
L	Top cover knock hole	/	/	9	229	10-7/8	275
M	Top cover knock hole	4-1/2	113	4-7/8	124	5-1/8	131
N	Top cover knock hole	2	51	2	51	1-5/8	41

Outdoor Unit Dimension

Unit: inch, mm

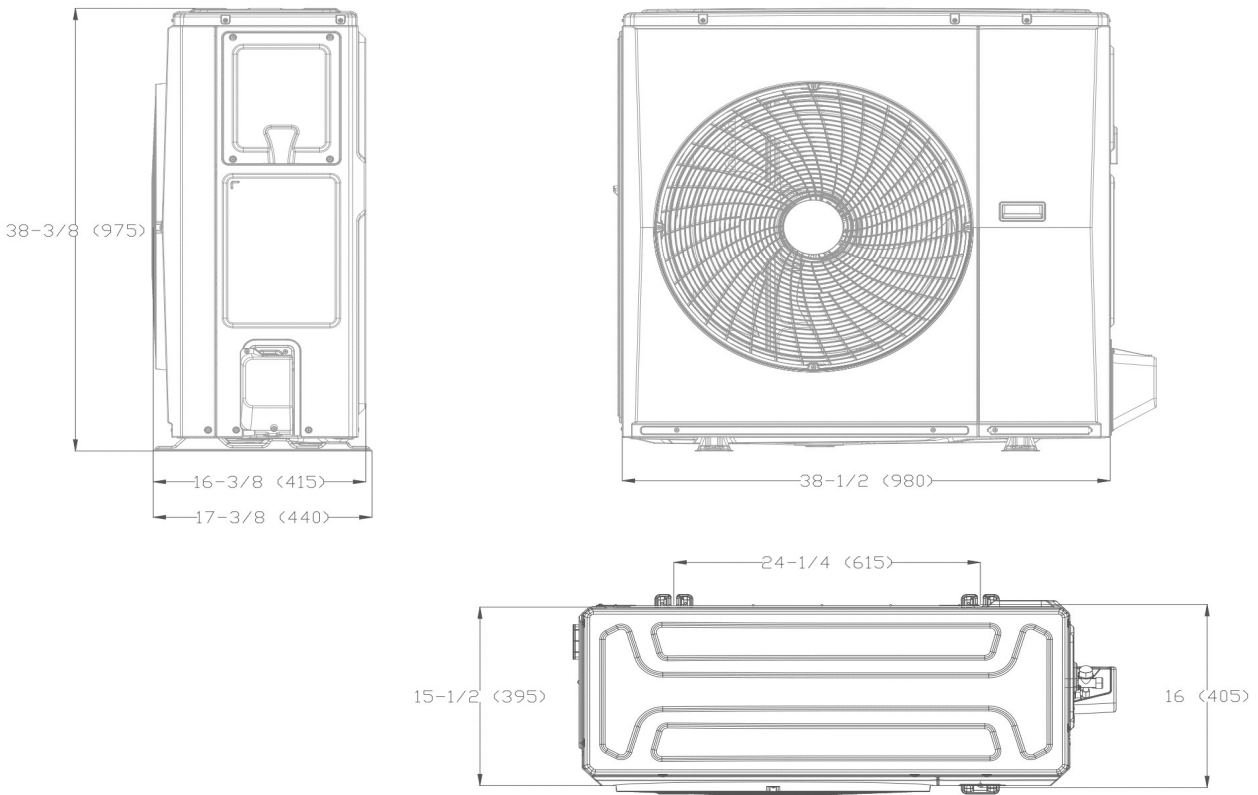

Installation Instruction For Outdoor Unit

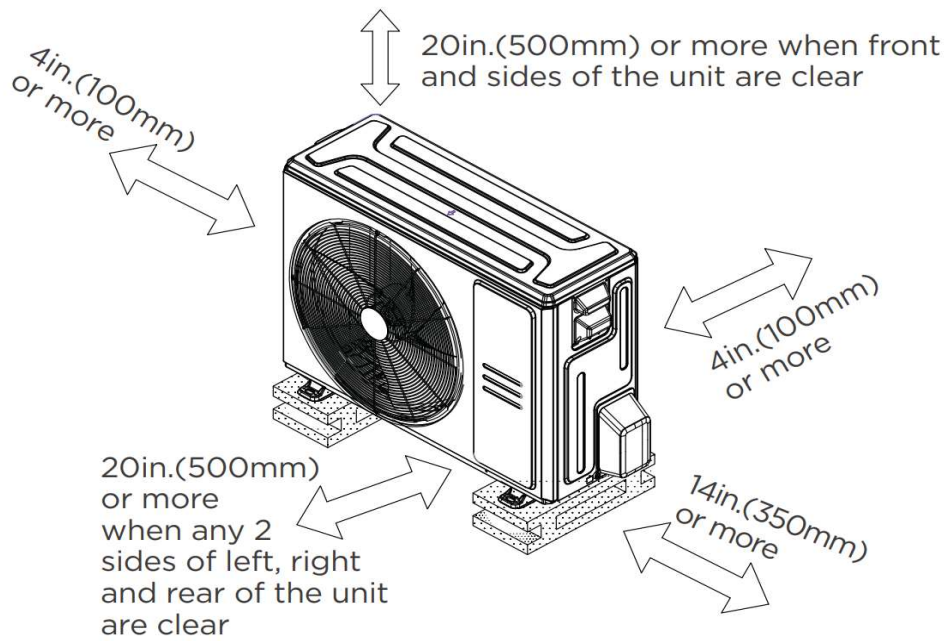

Fan Performance For Indoor Unit

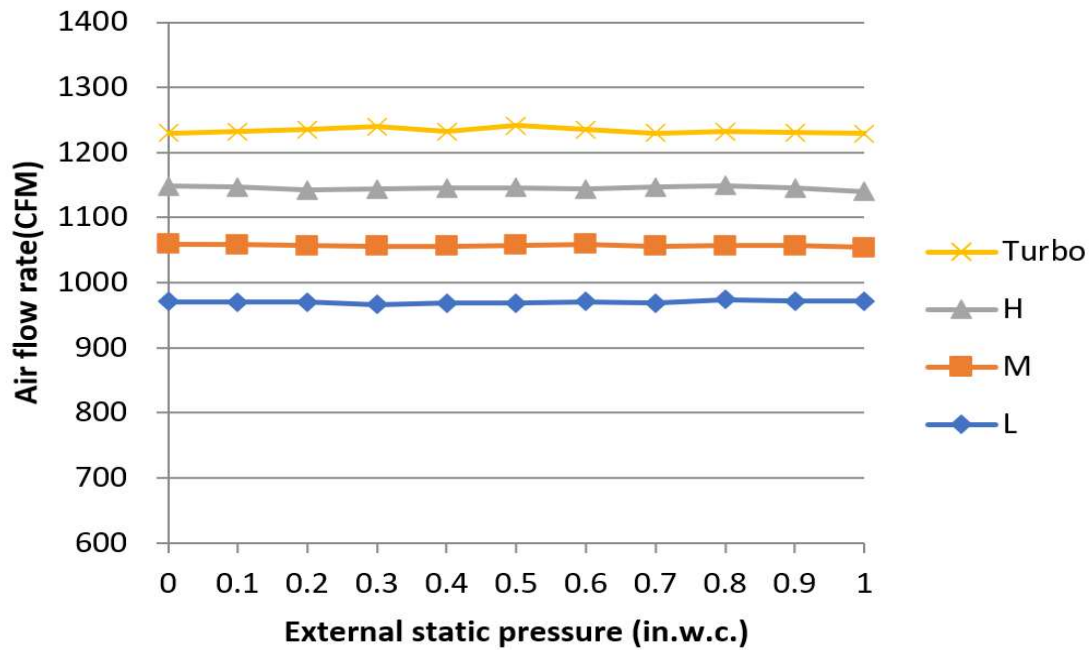

Features

- Multi-position installation: horizontal(left or right), vertical(up or down)
- The IDU supports 115/230V voltage compatibility
- Aluminum Coil
- Constant Air Flow system: Up to 1.0 In.W.G
- Optional Auxiliary heat kit up to 25kW
- Easy Maintenance
- Multiple control options available:
 - Two-way communication wired controller:120N(X6)
 - Two-way communication wired controller with built-in Wi-Fi: 120N (X6W)
 - Wireless remote controller
 - Third-Party 24V Thermostat
- Adaptive Control System
- High efficiency up to 19 SEER2, 12.5 EER2, 10.8 HSPF2
- 100% heating output down to -13°F*
- Base pan heater and crankcase heater are equipped as standard

* When MAUSE-H36B-2A is paired with MO1SE-H36B-2A, its rated heating capacity at -13°F is 100%