

# R454b Refrigerant

# SUBMITTAL DATA SHEET



Series Name: Extreme Heat AHU Series  
Model Number: MAUSE-H24B-2A/MO1HE-H24B-2A

### Air Handler Heat Pump System

Location:	Approval:
Engineer:	Date:
Submitted to:	Construction:
Submitted by:	Unit #:
Reference:	Drawing #:



### INDOOR SPECIFICATION

ESP(inWG)		0~1.0
Indoor Air Flow (Turbo/H/ML/SI) (CFM)		824 / 759 / 694 / 630 / 630
Indoor Noise Level (Turbo/H/ML/SI) (dBA)		47.5 / 47.5 / 44 / 33 / 33
Dimension (WxDxH)	inch	14-1/2 x 21-1/2 x 53-7/8
	mm	368 x 546 x 1368
Package (WxDxH)	inch	17-1/2 x 31-1/8 x 58-1/4
	mm	445 x 790 x 1480
Net/Gross Weight	lbs	123 / 155
	kg	55.8 / 70.2

### OUTDOOR SPECIFICATION

Compressor Type		ROTARY
Compressor Model		KTM240D46UKT2
Refrigerant		R454B
Refrigerant Oil Charge(mL)		620
Refrigerant Oil		VG74
Outdoor Air Flow (Max) (CFM)		1,766
Outdoor Noise Level (dBA)		59
Dimension (WxDxH)	inch	35 x 13-1/2 x 26-1/2
	mm	890 x 342 x 673
Package (WxDxH)	inch	39-1/8 x 15-5/8 x 29-1/8
	mm	995 x 398 x 740
Net/Gross Weight	lbs	102 / 109
	kg	46.4 / 49.5

### EFFICIENCY

Cooling		Heating	
SEER2	18.6	HSPF2-4	10.0
EER2	12.0	COP	3.49

### PERFORMANCE of Cooling

Cooling (Btu/hr)	
Rated Capacity	24,000
Min/Max Capacity	6,400 ~ 2,8800
Moisture Removal(L/h)	2.23
Standard Operating Range(°F/°C)	-22~122 (-30 ~ 50)
Rated Cooling Conditions:	Indoor: 80°F DB/67°F WB Outdoor: 95°F DB/75°F WB

### PERFORMANCE of Heating

Heating (Btu/hr)	
1. @ 47°F Rated	24,000
2. @ 47°F Min/Max Capacity	6,600 ~ 29,200
3. @ 17°F Rated	19,000
4. @ 5°F Rated: Capacity / COP	20,600 / 2.14
5. @ 5°F Max: Capacity	20,600
Standard Operating Range(°F/°C)	-22~75 (-30 ~ 24)
1. Rated Heating Conditions:	Indoor: 70°F DB/60°F WB Outdoor: 47°F DB/43°F WB
2. Rated Heating Conditions:	Indoor: 70°F DB/60°F WB Outdoor: 17°F DB/15°F WB
3. Heating Conditions, Compressor Operating at Max. Frequency	Indoor: 70°F DB/60°F WB Outdoor: 5°F DB/5°F WB

### ELECTRICAL

Indoor Power Supply	115/208/230V,60Hz,1Ph
Indoor MCA 115V/(208/230V)	5.5/3.5
Indoor MOP	15.0
Outdoor Power Supply	208/230V,60Hz,1Ph
Outdoor MCA	19.0
Outdoor MOP	20.0
Communication Wiring	AWG 20/2
Compressor RLA	14.0
Outdoor Fan Motor RLA	1.0
Outdoor Fan Motor W	80
Indoor Fan Motor RLA	2.5
Indoor Fan Motor W	600
System Power Input @ Cooling (W)	2000 (830 ~ 2,850)
System Power Input @ Heating (W)	2,010 (405 ~ 2,450)
MCA: Min. circuit amps (A)	MOCP: Max. over current protection (A)
RLA: Rated load amps (A)	W: Fan motor rated output (W)

### PIPING

Throttle type(Indoor)	EXV
Throttle type(Outdoor)	EXV
Liquid Size	3/8" (9.52mm)
Gas Size	3/4" (19mm)
Max. Piping Length(ft/m)	164 (50)
Max. Height Difference(ft/m)	82 (25)
Max. Pre-charged Length(ft/m)	25 (7.5)
Refrigerant Pre-charged Amount(oz/kg)	74 (2.1)
Additional Charge of Refrigerant(oz/ft)/(g/m)	0.7 (65)
Connection Method	Flared

Indoor Unit Dimension

Unit: inch, mm

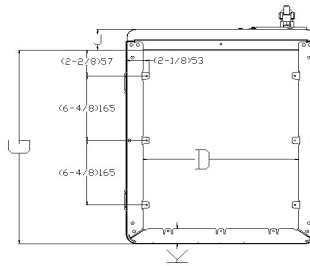
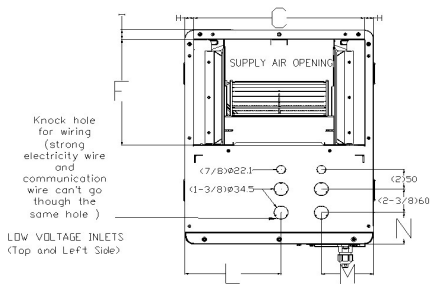
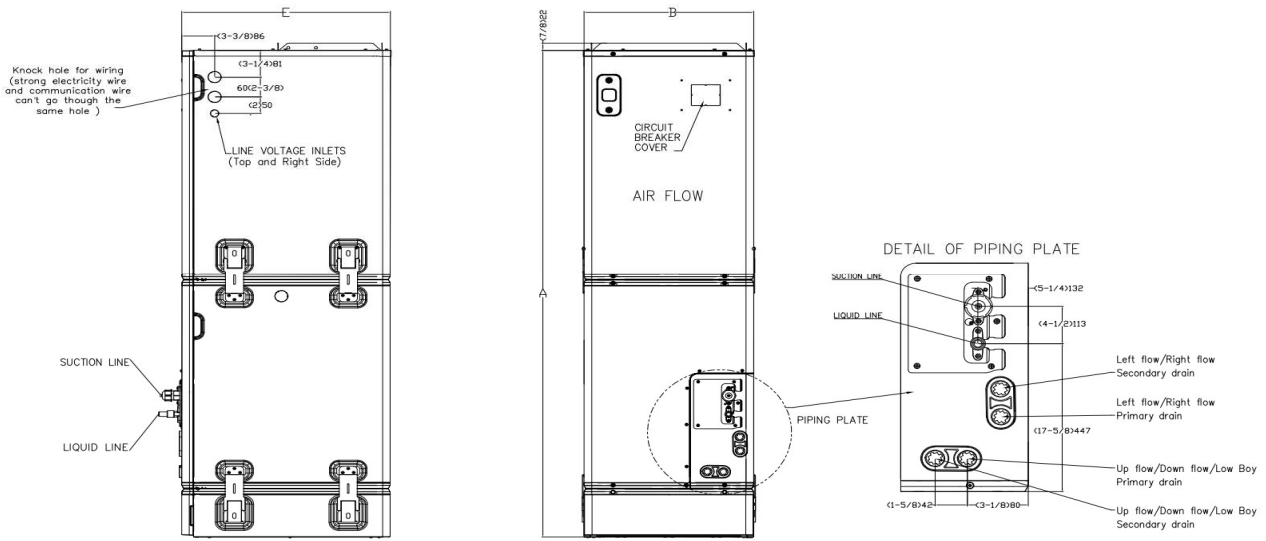

Dimensions	Model(Btu/h)	18K/24K		30K/36K		48K/54K	
		inch	mm	inch	mm	inch	mm
A	Model Height	53-7/8	1368	58-1/8	1476	60-1/8	1526
B	Model Width	14-4/8	368	17-4/8	445	21-4/8	546
C	Supply Air Opening Width	12-7/8	328	16	405	19-7/8	506
D	Return Air Opening Width	11-1/8	282	14-4/8	368	18-4/8	470
E	Model Depth	21-1/2	546	21-1/2	546	21-1/2	546
F	Supply Air Opening Depth	10-5/8	271	10-5/8	271	10-5/8	271
G	Return Air Opening Depth	19	484	19	484	19	484
H	Supply Air Opening Clearance	7/8	22	7/8	22	7/8	22
I	Supply Air Opening Clearance	1	24	1	24	1	24
J	Return Air Opening Front Clearance	2-4/8	62	2-4/8	62	2-4/8	62
K	Return Air Opening Back Clearance	1-4/8	37	1-4/8	37	1-4/8	37
L	Top cover knock hole	/	/	9	229	10-7/8	275
M	Top cover knock hole	4-1/2	113	4-7/8	124	5-1/8	131
N	Top cover knock hole	2	51	2	51	1-5/8	41

Outdoor Unit Dimension

Unit: inch (mm)

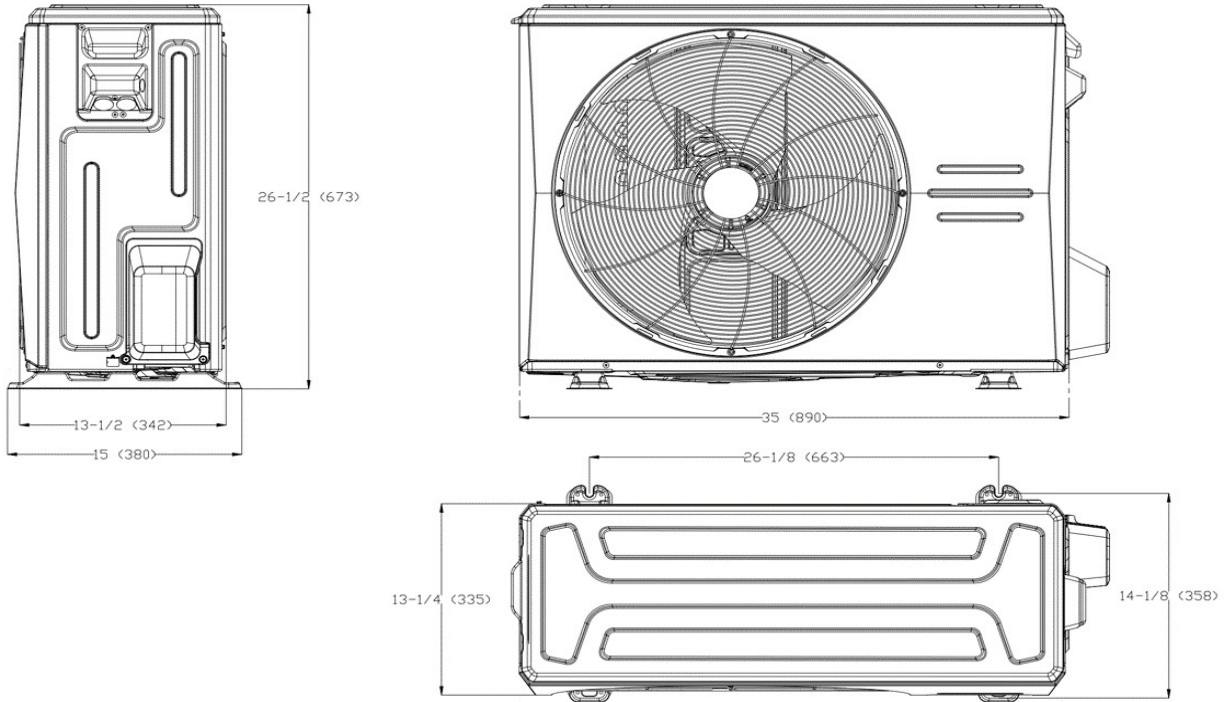

Installation Instruction For Outdoor Unit

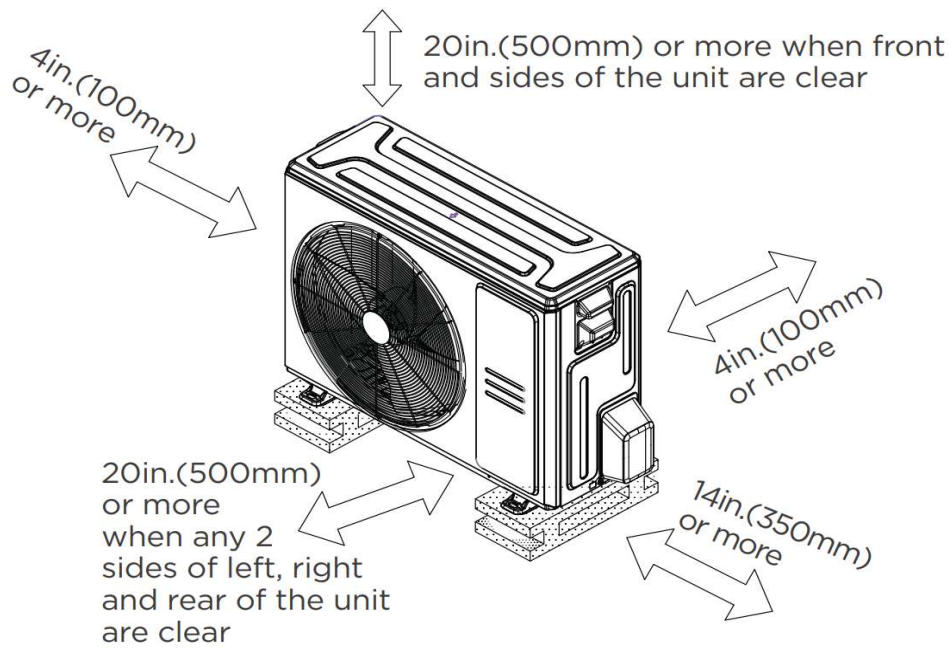

### Fan Performance For Indoor Unit

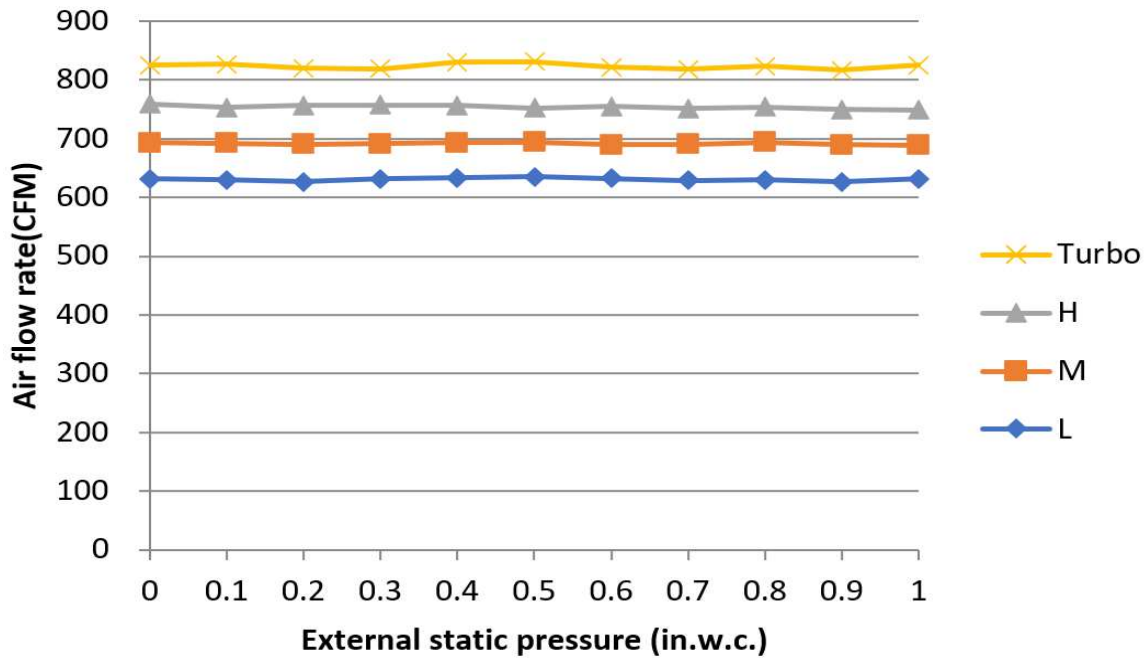

### Features

- Multi-position installation: horizontal(left or right), vertical( up or down)
- The IDU supports 115/230V voltage compatibility
- Aluminum Coil
- Constant Air Flow system: Up to 1.0 In.W.G
- Optional Auxiliary heat kit up to 25kW
- Easy Maintenance
- Multiple control options available:
  - Two-way communication wired controller:120N(X6)
  - Two-way communication wired controller with built-in Wi-Fi: 120N (X6W)
  - Wireless remote controller
  - Third-Party 24V Thermostat
- Adaptive Control System
- High efficiency up to 19 SEER2, 12.5 EER2, 10.8 HSPF2
- 100% heating output down to -13°F\*
- Base pan heater and crankcase heater are equipped as standard

\* When MAUSE-H36B-2A is paired with MO1SE-H36B-2A, its rated heating capacity at -13°F is 100%