

R454b Refrigerant

SUBMITTAL DATA SHEET



Series Name: Extreme Heat AHU Series
 Model Number: MAUHE-H30B-2A/MO1HE-H30B-2A

Air Handler Heat Pump System

Location:	Approval:
Engineer:	Date:
Submitted to:	Construction:
Submitted by:	Unit #:
Reference:	Drawing #:



INDOOR SPECIFICATION

ESP(in.W.G)	0-0.8	
Indoor Air Flow (Turbo/H/ML/SI) (CFM)	989 / 895 / 806 / 712 / 712	
Indoor Noise Level (Turbo/H/ML/SI) (dBA)	47 / 46 / 43 / 27.5 / 27.5	
Dimension (WxDxH)	inch	21 x 21 x 49
	mm	534 x 534 x 1245
Package (WxDxH)	inch	24-7/16 x 26-9/16 x 52-9/16
	mm	620 x 675 x 1335
Net/Gross Weight	lbs	129 / 153
	kg	58.5 / 69.6

OUTDOOR SPECIFICATION

Compressor Type	ROTARY	
Compressor Model	MTH356UKRC8FQL	
Refrigerant	R454B	
Refrigerant Oil Charge(mL)	1,300	
Refrigerant Oil	HAF68D1A	
Outdoor Air Flow (Max) (CFM)	3,002	
Outdoor Noise Level (dBA)	60.5	
Dimension (WxDxH)	inch	37-1/4 x 16-1/8 x 31-7/8
	mm	946 x 410 x 810
Package (WxDxH)	inch	42-7/8 x 19-5/8 x 34-7/8
	mm	1090 x 500 x 885
Net/Gross Weight	lbs	164 /175
	kg	74.4 / 79.2

EFFICIENCY

Cooling		Heating	
SEER2	16.8	HSPF2-4	10.0
EER2	11.7	COP	3.65

PERFORMANCE of Cooling

Cooling (Btu/hr)	
Rated Capacity	30,000
Min/Max Capacity	12,800 ~ 39,000
Moisture Removal(L/h)	2.77
Standard Operating Range(*F/*C)	-22~122(-30 ~ 50)
Rated Cooling Conditions:	Indoor: 80°F DB/67°F WB Outdoor: 95°F DB/75°F WB

PERFORMANCE of Heating

Heating (Btu/hr)	
1. @ 47°F Rated	34,000
2. @ 47°F Min/Max Capacity	10,300 ~ 38,500
3. @ 17°F Rated	23,800
4. @ 5°F Rated: Capacity / COP	32,600/1.96
5. @ 5°F Max: Capacity	32,600
Standard Operating Range(*F/*C)	-22~75 (-30 ~ 24)
1. Rated Heating Conditions:	Indoor: 70°F DB/60°F WB Outdoor: 47°F DB/43°F WB
2. Rated Heating Conditions:	Indoor: 70°F DB/60°F WB Outdoor: 17°F DB/15°F WB
3. Heating Conditions, Compressor Operating at Max. Frequency	Indoor: 70°F DB/60°F WB Outdoor: 5°F DB/5°F WB

ELECTRICAL

Indoor Power Supply	115/208/230V,60Hz,1Ph
Indoor MCA 115V/(208/230V)	8.0/6.0
Indoor MOP	15.0
Outdoor Power Supply	208/230V,60Hz,1Ph
Outdoor MCA	29.5
Outdoor MOP	30.0
Communication Wiring	AWG 20/2
Compressor RLA	22.4
Outdoor Fan Motor RLA	1.5
Outdoor Fan Motor W	120
Indoor Fan Motor RLA	4.5
Indoor Fan Motor W	375
System Power Input @ Cooling (W)	2,567(850 ~ 3,620)
System Power Input @ Heating (W)	2,790(655 ~ 3,020)
MCA: Min. circuit amps (A)	MOCP: Max. over current protection (A)
RLA: Rated load amps (A)	W: Fan motor rated output (W)

PIPING

Throttle type(Indoor)	EXV
Throttle type(Outdoor)	EXV
Liquid Size	3/8" (9.52mm)
Gas Size	3/4" (19mm)
Max. Piping Length(ft/m)	164 (50)
Max. Height Difference(ft/m)	82 (25)
Max. Pre-charged Length(ft/m)	25 (7.5)
Refrigerant Pre-charged Amount(oz/kg)	106 (3)
Additional Charge of Refrigerant(oz/ft)/(g/m)	0.7 (65)
Connection Method	Flared

Indoor Unit Dimension

Unit:inch(mm)

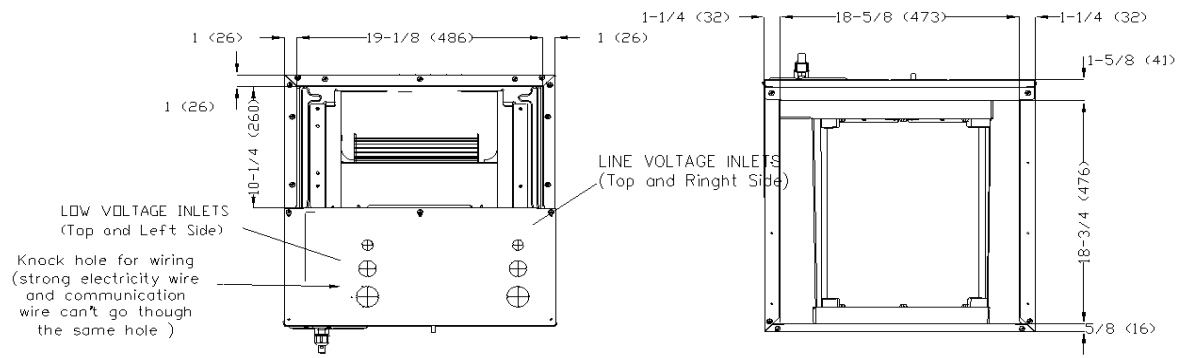
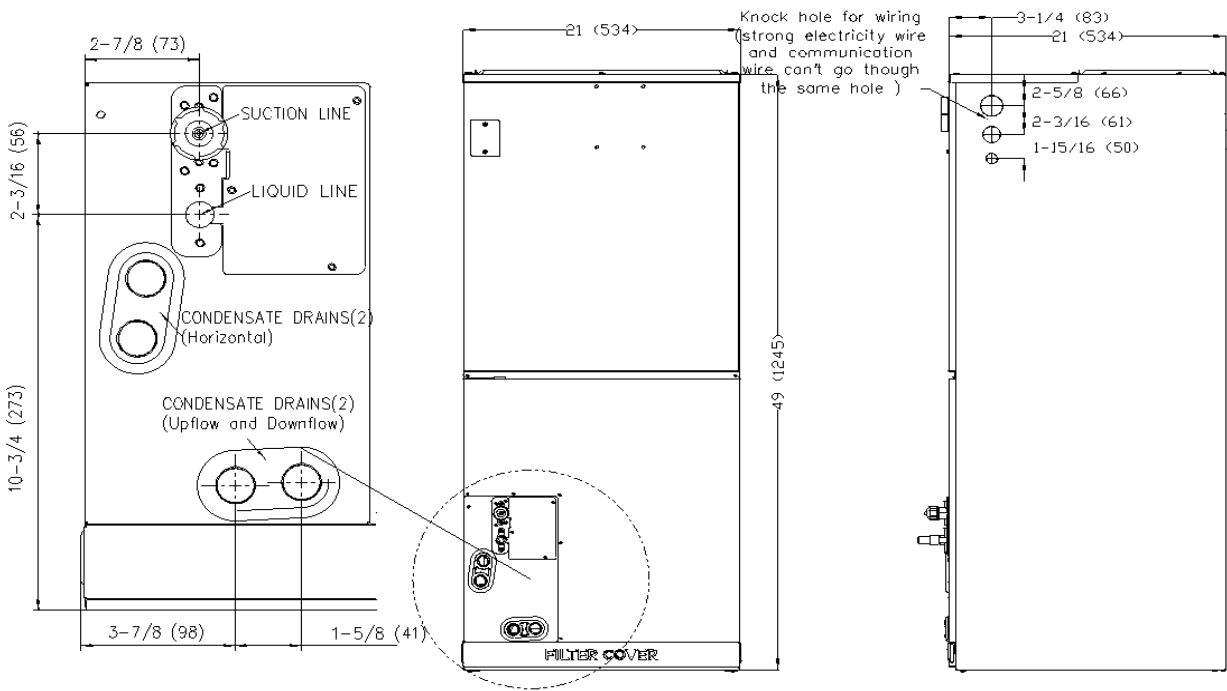

Outdoor Unit Dimension

Unit:inch(mm)

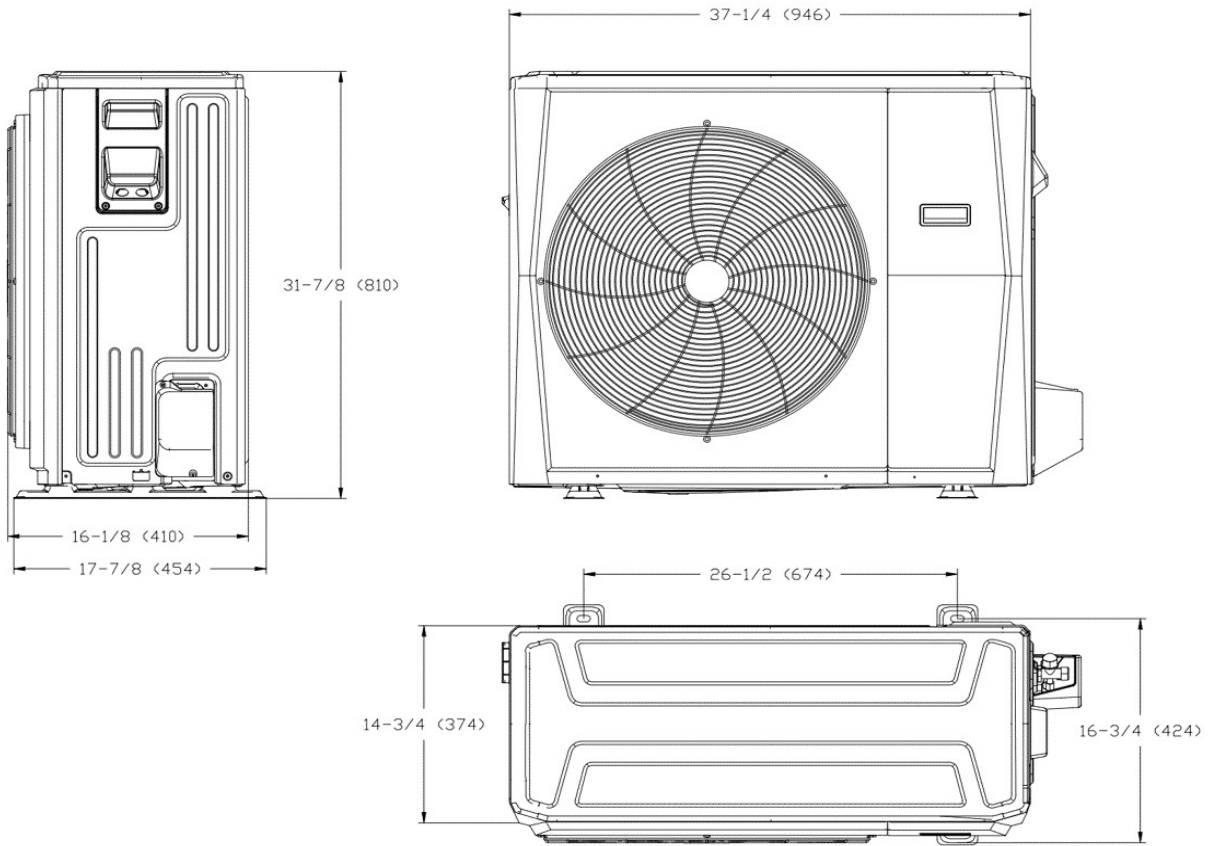

Installation Instruction For Outdoor Unit

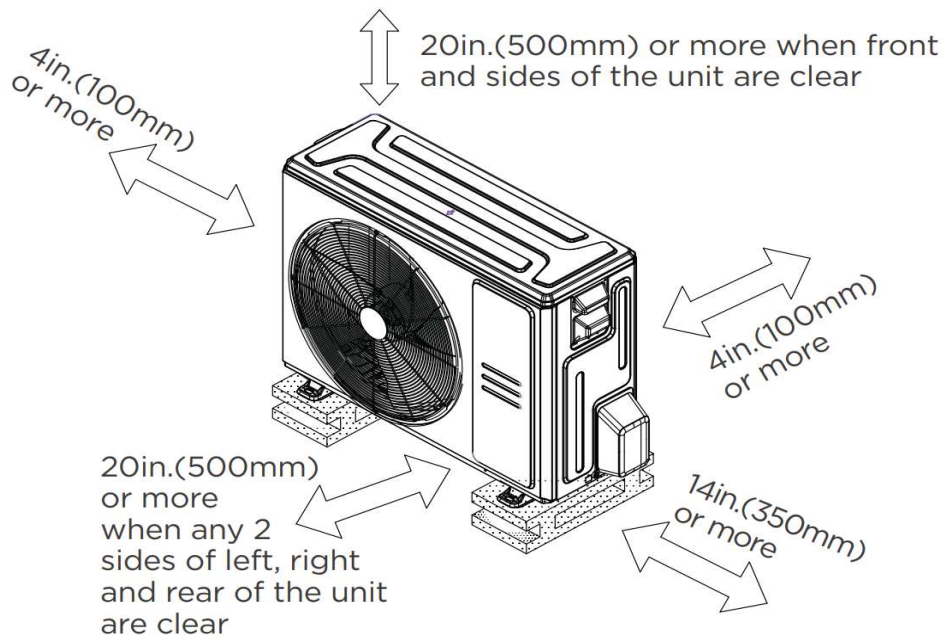

Fan Performance For Indoor Unit

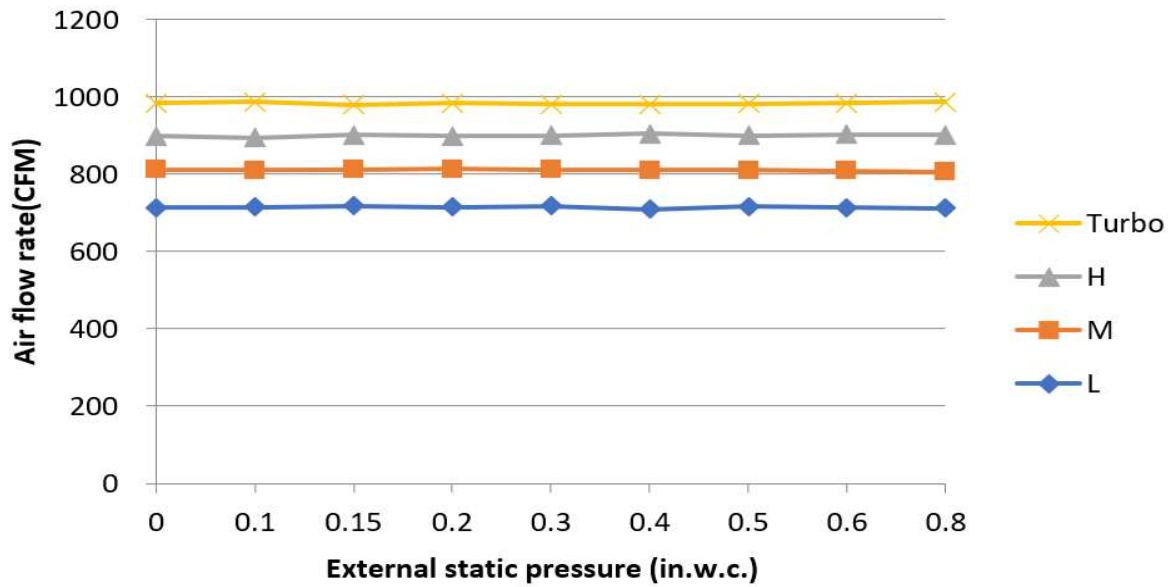

Features

- Multi-position installation: horizontal(left or right), vertical(up or down)
- Aluminum Coil
- Constant Air Flow system: Up to 0.80 In.W.G
- 1 inch R-4.2 fiberglass insulation reduces condensation and boosts efficiency(optional)
- Optional Auxiliary heat kit up to 25kW
- Easy Maintenance
- Multiple control options available:
 - Two-way communication wired controller:120N(X6)
 - Two-way communication wired controller with built-in Wi-Fi: 120N (X6W)
 - Wireless remote controller
 - Third-Party 24V Thermostat
- Adaptive Control System
- High efficiency up to 19 SEER2, 12.5 EER2, 10.3 HSPF2
- 100% heating output at -4°F*
- Base pan heater and crankcase heater are equipped as standard

* When MAUHE-H36B-2A is paired with MO1SE-H36B-2A, its rated heating capacity at -4°F is 100%