

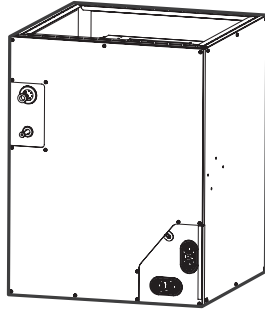

# Owner's Manual Air Handler

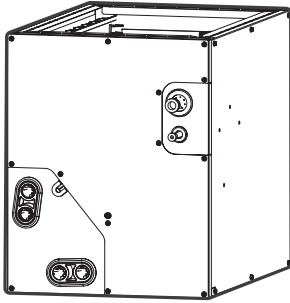

A-Coil Model

BTUH	AHU MODEL
24,000	MAAHE-H24B-AA
24,000	MAAHE-H24B-BA
36,000	MAAHE-H36B-AA
36,000	MAAHE-H36B-BA
36,000	MAAHE-H36B-CA
60,000	MAAHE-H60B-CA
60,000	MAAHE-H60B-DA

Evox G3 Extreme Heat

BTUH	AHU MODEL
18,000	MAUSE-H18B-2A
24,000	MAUSE-H24B-2A
30,000	MAUSE-H30B-2A
36,000	MAUSE-H36B-2A
48,000	MAUSE-H48B-2A
60,000	MAUSE-H60B-2A

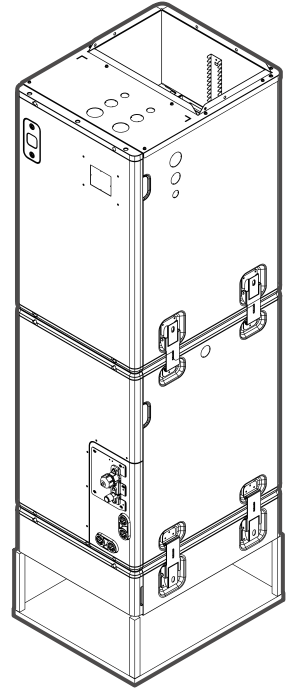

Wall Mounted Air Handler

BTUH	AHU MODEL
18,000	MAWHE-H18B-2A
24,000	MAWHE-H24B-2A
30,000	MAWHE-H30B-2A
36,000	MAWHE-H36B-2A

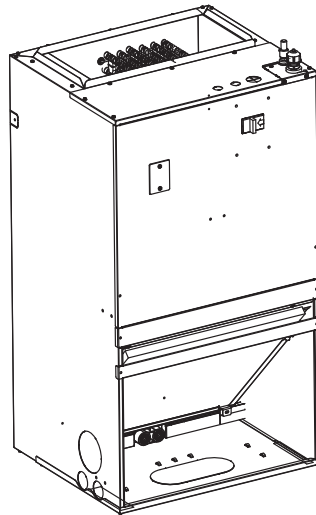

Evox G2 Extreme Heat

BTUH	AHU MODEL
18,000	MAUHE-H18B-2A
24,000	MAUHE-H24B-2A
30,000	MAUHE-H30B-2A
36,000	MAUHE-H36B-2A
48,000	MAUHE-H48B-2A
60,000	MAUHE-H60B-2A

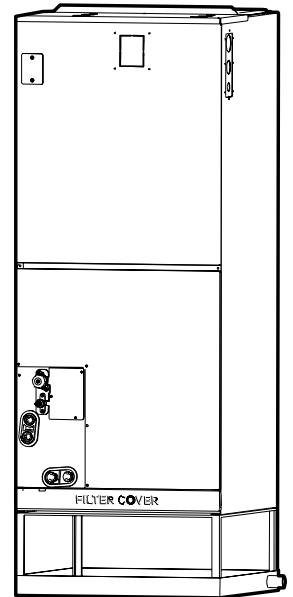

Ceiling Mounted Air Handler

BTUH	AHU MODEL
18,000	MAPHE-H18B-2A
24,000	MAPHE-H24B-2A
30,000	MAPHE-H30B-2A
36,000	MAPHE-H36B-2A

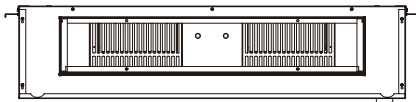

## NOTE

Please read this manual carefully before operating your new air conditioning unit and save it for future reference.



# Table of Contents

<b>Safety Considerations</b> .....	<b>3</b>
Table S-1: Explanation of symbols displayed on the indoor unit or outdoor unit .....	4
<b>System Operation and Features</b> .....	<b>5</b>
Table SOF-1: Inverter Split System Limitations.....	5
<b>Care &amp; Maintenance</b> .....	<b>6</b>
Filter Locations.....	7
MAUHE-H**B-2A.....	7
MAUSE-H**B-2A .....	7
MAWHE-H**B-2A.....	7
<b>Troubleshooting</b> .....	<b>8</b>
Table TS-1: Common Issues .....	8
When To Call For Repairs .....	9

## Read this manual

You'll find many helpful hints on how to use and maintain your air conditioner properly. Just a little preventive care on your part can save you a great deal of time and money over the life of your air conditioner. These instructions may not cover every possible condition of use, so common sense and attention to safety are required when operating and maintaining this product.



### Caution:

Risk of fire/flammable materials



# A2L

# Safety Considerations

You must read the Safety Precautions Before Operation. Incorrect operation due to ignoring instructions can cause serious damage or injury. The seriousness of potential damage or injuries is classified as either a WARNING or CAUTION.

## **WARNING**

Hazards or unsafe practices that may result in severe personal injury or death.

## **CAUTION**

Hazards or unsafe practices may result in minor personal injury or property damage. Carefully follow the precautions because they are essential to guarantee the safety of the equipment.

### **NOTE**

A property-damage-only hazard, meaning no personal injury is possible.

### **IMPORTANT**

Is used to highlight suggestions which will result in enhanced reliability or operation.

## **WARNING**

State of California Proposition 65 Warning (US Only)  
This product contains chemicals known to the State of California to cause cancer, birth defects, or other reproductive harm.

## **WARNING**

Improper installation, adjustment, alteration, service, maintenance, or use can cause an explosion, fire, electrical shock, or other conditions that may cause death, personal injury, or property damage. Consult a qualified installer, service agency, distributor, or branch for information or assistance. The qualified installer or agency must use factory-authorized kits or accessories when modifying this product.

## **WARNING**

This appliance is not intended for use by persons (including children) with reduced physical, sensory or mental capabilities, or lack of experience and knowledge, unless they have been given supervision or instruction concerning use of the appliance by a person responsible for their safety. Children should be supervised to ensure that they do not play with the appliance.

## **WARNING**

### **FOR PRODUCT USE**

- Turn off the air conditioner and disconnect the power before performing any cleaning. Failure to do so can

cause electric shock.

- If an abnormal situation arises (like a burning smell), immediately turn off the unit and disconnect the power. Call your dealer for instructions to avoid electric shock, fire, or injury.
- **Do not** insert fingers, rods, or other objects into the air inlet or outlet. This may cause injury, since the fan may be rotating at high speeds.
- **Do not** use flammable sprays such as hair spray, lacquer, or paint near the unit. This may cause fire or combustion.
- **Do not** operate the air conditioner in places near or around combustible gases. Emitted gas may collect around the unit and cause an explosion.
- **Do not** operate your air conditioner in a wet room such as a bathroom or laundry room. Too much exposure to water can cause electrical components to short circuit.
- **Do not** expose your body directly to cool air for a prolonged time.
- **Do not** allow children to play with the air conditioner. Children must be always supervised around the unit.
- If the air conditioner is used together with burners or other heating devices, thoroughly ventilate the room to avoid oxygen deficiency.
- In certain functional environments, such as kitchens, server rooms, etc., the use of specially designed air-conditioning units is highly recommended.

## **WARNING**

### **FOR CLEANING AND MAINTENANCE**

- Turn off the device and disconnect the power before cleaning. Failure to do so can cause electrical shock.
- **Do not** clean the air conditioner with excessive amounts of water.
- **Do not** clean the air conditioner with combustible cleaning agents. Combustible cleaning agents can cause fire or deformation.

## **CAUTION**





### **USING FLAMMABLE REFRIGERANT**

- Do not use means to accelerate the defrosting process or to clean, other than those recommended by the manufacturer.
- The appliance shall be stored in a room without continuously operating ignition sources (for example: open flames, an operating gas appliance, or an operating electric heater).
- **Do not pierce or burn.**
- Be aware that refrigerants may not contain an odor.
- **LEAK DETECTION SYSTEM** installed. The unit must be powered except for service. For the unit with a refrigerant sensor, when the refrigerant sensor detects refrigerant leakage, the indoor unit will display an error code and emit a buzzing sound, the compressor of the outdoor unit will immediately stop, and the indoor fan will start running. The service life of the refrigerant sensor is 15 years.
- The refrigerant sensor cannot be repaired and can only be replaced by the manufacturer. It shall only be

replaced with the sensor specified by the manufacturer.

- Any person who is involved with working on or breaking into a refrigerant circuit should hold a currently valid certificate from an industry-accredited assessment authority, which authorizes their competence to handle refrigerants safely following an industry-recognized assessment specification.

**Table S-1: Explanation of symbols displayed on the indoor unit or outdoor unit**

	<b>WARNING</b>	This symbol shows that this appliance used a flammable refrigerant. If the refrigerant is leaked and exposed to an external ignition source, there is a risk of fire.
	<b>CAUTION</b>	This symbol shows that the operation manual should be read carefully.
	<b>CAUTION</b>	This symbol shows that service personnel should be handling this equipment referencing the installation manual.
	<b>CAUTION</b>	This symbol shows that information is available such as the owner's manual or installation manual.

# System Operation and Features

## Operating Conditions

Use the system under the following temperatures for safe and effective operation. If the air conditioner is used under different conditions, it may malfunction or become less efficient.

**Table SOF-1: Inverter Split System Limitations**

Location Temperature	COOL Mode	HEAT Mode	DRY Mode
Room Temperature	60°F - 90°F (16°C - 32°C)	32°F - 86°F (0°C - 30°C)	50°F - 90°F (10°C - 32°C)
Outdoor Temperature	-22°F - 122°F (-30°C - 50°C) (For Extreme Heat Series)	-22°F - 75°F (-30°C - 24°C) (For Extreme Heat Series)	32°F - 122°F (0°C - 50°C)
	-13°F - 122°F (-25°C - 50°C) (For Regular Heat Series)	-13°F - 75°F (-25°C - 24°C) (For Regular Heat Series)	

## For Outdoor Units With Auxiliary Electric Heater

When the outside temperature is below 32°F (0°C), we strongly recommend keeping the outdoor unit powered at all times to prevent damage to equipment.

### NOTE

Room relative humidity less than 80%. If the air conditioner operates over this figure, the surface of the air conditioner may attract condensation.

## To Optimize The Performance Of Your Unit, Do The Following:

- Keep doors and windows closed.
- Limit energy usage by using **TIMER ON** and **TIMER OFF** functions.
- Do not block air inlets or outlets.
- Regularly inspect and clean air filters.

## Refrigerant Leak Detection System

When the system detects a malfunction of the refrigerant, the indoor unit will automatically display the following error codes:

- "ELOC (System lacks refrigerant)", "EHC1 (Refrigerant sensor detects leakage)", "EHC2 (Working condition of the refrigerant sensor is out of range and leakage is detected)", "EHC3 (Working condition of the refrigerant sensor is out of range)", or "ECC1 (Other indoor unit refrigerant sensor detects leakage (multi-zone))".
- When the "EHC1" or "EHC2" error occurs, the buzzer will continue to beep for 5 to 6 minutes before stopping. You can also press any button on the remote controller to stop the buzzer.

### NOTE

- Under normal working conditions, the switch, wind speed, and temperature cannot be adjusted by remote

control.

- Requirements of the wired controller: Control AUX function for live heating.

## Energy Saving Tips

- **DO NOT** set the unit to excessive temperature levels.
- While cooling, close the curtains or blinds to avoid direct sunlight.

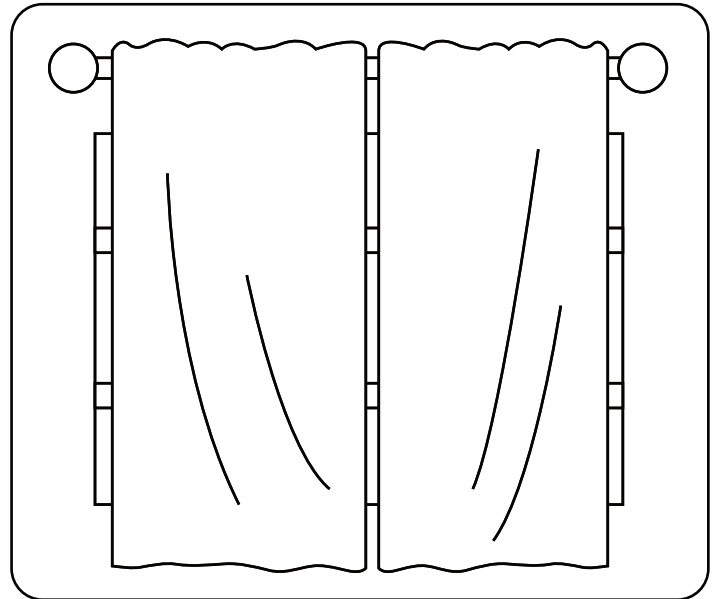

- Closing curtains or blinds during heating also helps keep the heat in.

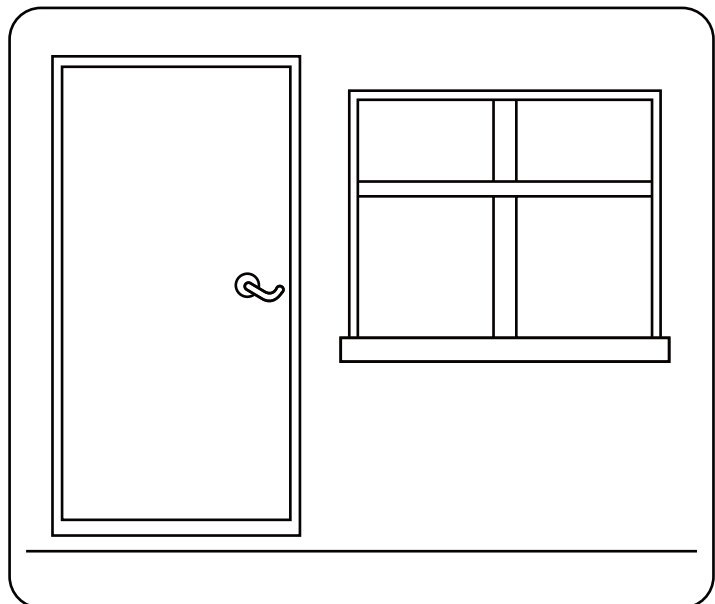

- Doors and windows should be kept closed to keep cool or warm air in the room.
- **DO NOT** place objects near the air inlet and outlet of the unit.
- Replace the air filter every 30 to 90 days depending on thickness and MERV rating. See the Dimensions section of your installation manual for the recommended filter size for your unit.

# Care & Maintenance

## ⚠ WARNING

### Before Cleaning Or Maintenance

Always turn off your air conditioner system and disconnect its power supply before cleaning or maintenance.

- Contact an authorized service technician for repair or maintenance. Improper repair and maintenance may cause water leakage, electrical shock, or fire and may void your warranty.
- **Do not** substitute a blown fuse with a higher or lower amperage rating fuse, as this may cause circuit damage or an electrical fire. The replacement Fuse must be identical to the one removed.
- Make sure the drain hose is set up according to the instructions. Failure to do so could cause leakage and result in personal property damage, fire, and electric shock.
- Make sure that all wires are connected properly. Failure to connect wires according to instructions can result in electrical shock or fire.

## ⚠ CAUTION

Only use a soft, dry cloth to wipe the unit clean. If the unit is especially dirty, you can use a cloth soaked in warm water to wipe it clean.

- **Do not** use chemicals or chemically treated cloths to clean the unit.
- **Do not** use benzene, paint thinner, polishing powder or other solvents to clean the unit. They can cause the plastic surface to crack or deform. Use of volatile cleaners may cause fire, resulting in injury or death.
- **Do not** use water hotter than 104°F (40°C) to clean the front panel. This can cause the panel to deform or become discolored.
- **Do not** wash the unit under running water. Doing so creates an electrical hazard.
- Clean the unit using a damp, lint-free cloth and neutral detergent. Dry the unit with a dry, lint-free cloth.

### NOTE

Inspect, clean, or replace the air filter each month or as required.

The user needs to purchase a standard filter that meets the requirements of UL900. See the Dimensions section of your installation manual for the recommended filter size for your unit.

## ⚠ CAUTION

- Before changing the filter or cleaning, turn off the unit and disconnect its power supply.
- When removing the filter, do not touch metal parts in the unit. The sharp metal edges can cut you.
- Do not use water to clean the inside of the indoor unit. This can destroy insulation and cause electrical shock.
- Do not expose the filter to direct sunlight when drying. This can shrink the filter.

- Any maintenance and cleaning of the outdoor unit should be performed by an authorized dealer or a licensed service provider.
- Any unit repairs should be performed by an authorized dealer or a licensed service provider.

### Maintenance of your AHU

#### Long Periods of Non-Use:

If you plan not to use your air conditioner for an extended period, do the following:

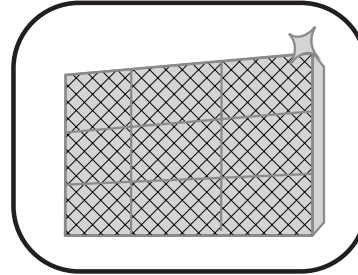

Clean or replace the filters

Turn on the FAN function until the unit dries out completely



### Pre-Season Inspection

After long periods of non-use, or before periods of frequent use, do the following:



Check for damaged wires



Check for leaks



Make sure nothing is blocking any air inlets or outlets

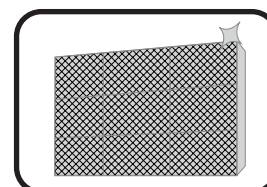

Clean or replace all filters

# Filter Locations

**⚠ CAUTION**

When removing the filter, precautions must be taken to protect your eyes from dust. If you must climb up a ladder to do the job, be careful not to fall. When the filter is removed, do not touch the metallic parts inside the indoor unit, otherwise, an injury may result.

**Removal and replacement of filter**

Pull the panel marked "FILTER COVER" out. Remove the old filter and replace with a new one. Push the panel back.

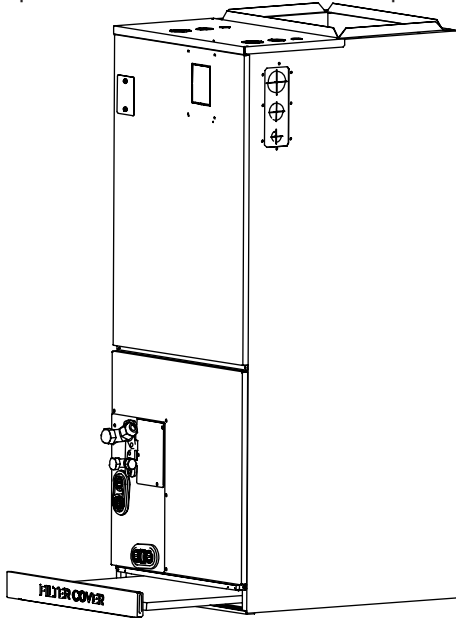

**MAUHE-H\*\*B-2A**

Slide the filter out and replace it with a new one.

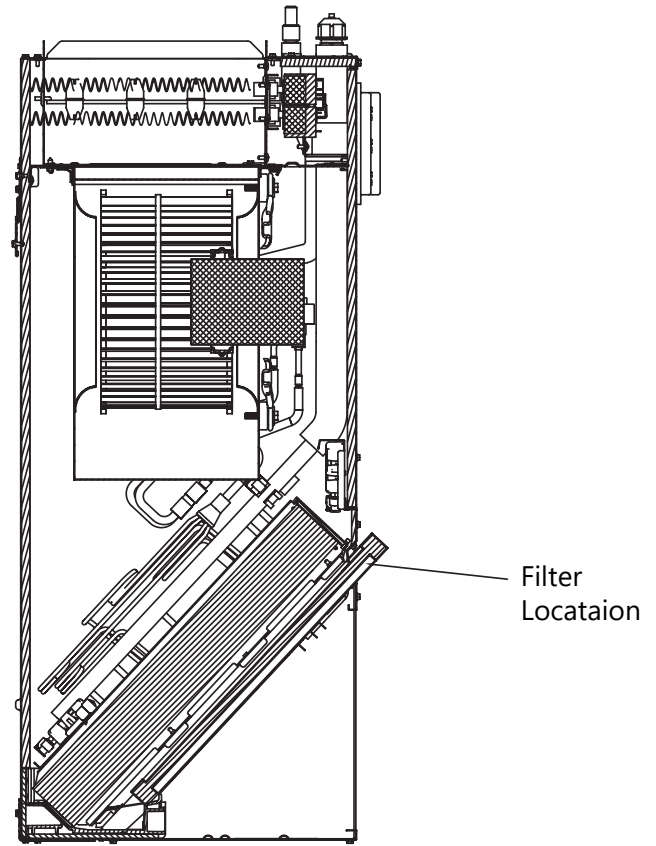

**MAWHE-H\*\*B-2A**

You should replace or clean the external filters if you have the Ceiling-Mounted AHU or the A-Coil.

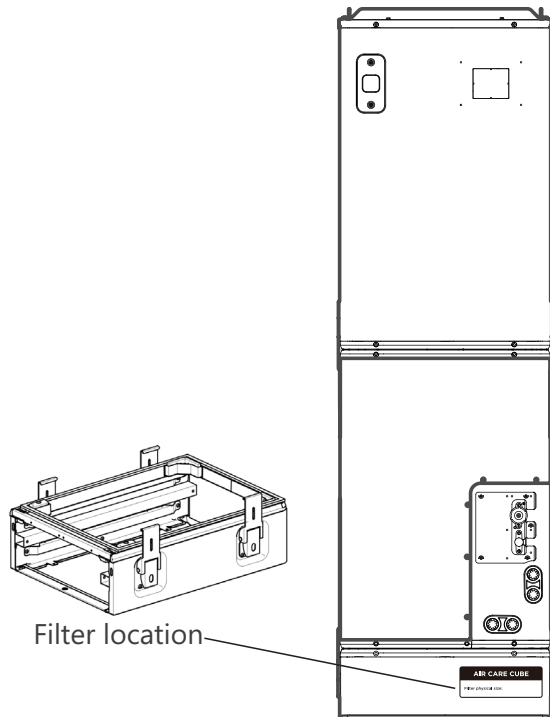

**MAUSE-H\*\*B-2A**

# Troubleshooting

**Table TS-1: Common Issues**

The following problems are not malfunctions and, in most situations, will not require repairs.

Issue	Possible Causes
The unit does not turn on when pressing the ON/OFF button	The Unit has a 3-minute protection feature that prevents the unit from overloading. The unit cannot be restarted within three minutes of being turned off.
	Cooling and Heating Models: If the Operation light and PRE-DEF (Pre-heating/ Defrost) indicators are lit up, the outdoor temperature is too cold, and the unit's anti-cold wind is activated to defrost the unit.
	In Cooling-only Models: If the "Fan Only" indicator is lit up, the outdoor temperature is too cold, and the unit's anti-freeze protection is activated to defrost the unit.
The unit changes from COOL/HEAT mode to FAN mode	The unit may change its setting to prevent frost from forming on the unit. Once the temperature increases, the unit will start operating in the previously selected mode again.
	Once the set temperature has been reached, the unit turns off the compressor. It will continue operating when the temperature fluctuates again.
The indoor unit emits a white mist	In humid regions, a large temperature difference between the room's air and the conditioned air can cause white mist.
Both the indoor and outdoor units emit white mist	When the unit restarts in HEAT mode after defrosting, a white mist may be emitted due to moisture generated from the defrosting process.
The indoor unit makes noises	A squeaking sound is heard when the system is OFF or in COOL mode. The noise is also heard when the drain pump (optional) is in operation.
	A squeaking sound may occur after running the unit in HEAT mode due to the expansion and contraction of the unit's plastic parts.
Both the indoor unit and outdoor unit make noises	Low hissing sound during operation: This is normal and is caused by refrigerant gas flowing through both indoor and outdoor units
	Low hissing sound when the system starts, has just stopped running, or is defrosting: This noise is normal and is caused by the refrigerant gas stopping or changing direction.
	Squeaking sound: Normal expansion and contraction of plastic and metal parts caused by temperature changes during operation can cause squeaking noises.
The outdoor unit makes noises	The unit will make different sounds based on its current operating mode.
Dust is emitted from either the indoor or outdoor unit	The unit may accumulate dust during extended periods of non-use, which will be emitted when the unit is turned on. This can be mitigated by covering the unit during long periods of inactivity.
The unit emits a bad odor	The unit may absorb odors from the environment (such as furniture, cooking, cigarettes, etc.) which will be emitted during operations.
	The unit's filters have become moldy and should be cleaned.
The fan of the outdoor unit does not operate	During operation, the fan speed is controlled to optimize product operation.

## NOTE

If the problem persists, contact a local dealer. Provide them with a detailed description of the unit malfunction as well as your model number.

# When To Call For Repairs

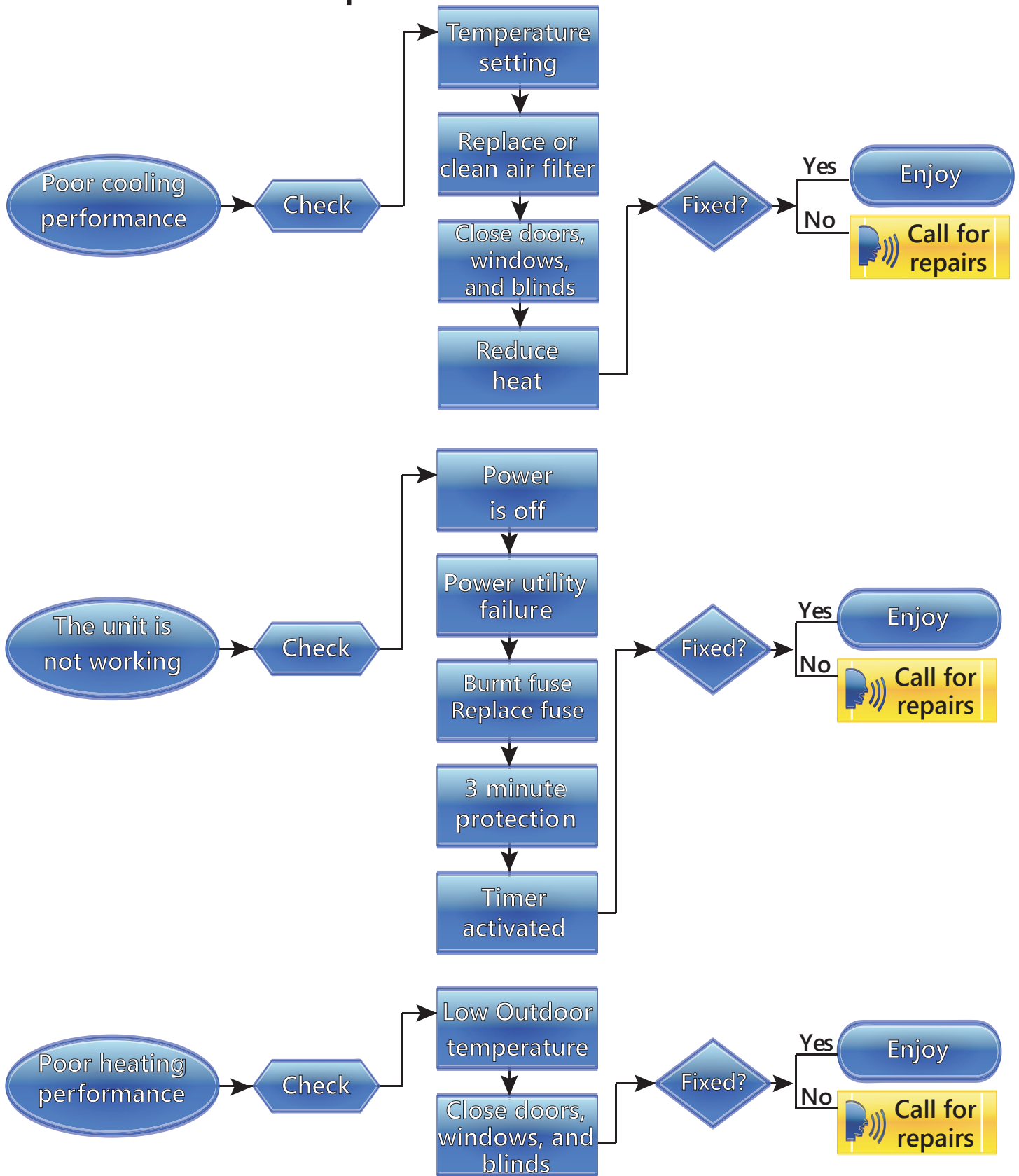

## NOTE

Consult your technician for maintenance procedures for your system.



The design and specifications may change without prior notice in order to enhance the product. For detailed information, please consult your sales agency or the manufacturer. Any updates to the manual will be posted on the service website, so be sure to check for the latest version.

## **Important!**

### **Product Warranty Information**

The Warranty Registration below is a requirement to print a warranty certificate. You're not mandated to register your products to enjoy the Midea Standard Warranty; however, registration is highly recommended. Registering your warranty within 60 days ensures easy access to support and service when needed.

#### **United States**



<https://www.mideacomfort.us/registration.html>

#### **Canada**

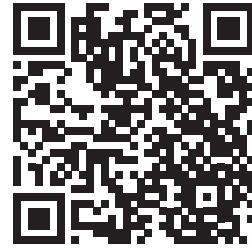

<https://www.mideacomfortna.ca/registration.html>