

Midea Installation Manual

Multi-Zone Outdoor Unit



For 18,000 - 55,000 BTU Systems



Units Covered In This Manual

SYSTEM ZONES	BTU/H	VOLTAGE/ PHASE	OUTDOOR MODEL
3	18,000	208/230-1	M03EX-H18B-2A
4	27,000	208/230-1	M04EX-H27B-2A
5	36,000	208/230-1	M05EX-H36B-2A
6	48,000	208/230-1	M06EX-H48B-2A
6	60,000	208/230-1	M06EX-H60B-2A
3	19,000	208/230-1	M03HX-H18B-2A
4	27,000	208/230-1	M04HX-H27B-2A
5	36,000	208/230-1	M05HX-H36B-2A
6	47,000	208/230-1	M06HX-H48B-2A
6	51,000	208/230-1	M06HX-H60B-2A

NOTE

Read the entire instruction manual before starting the installation. Images are for illustration purposes only. Actual models may differ slightly.



Manufacturer reserves the right to change, at any time, specifications and designs without notice and without obligations.

Table of Contents

Safety Considerations	3	Fig. 2-2: A B System Connection.....	19
Table S-1: Minimum Room Area Requirements.....	5	Step 3 - Install Drain Joint	19
Table S-2: Minimum Room Area Requirements.....	5	Fig. 3-1: Drain Joint Assembly	19
Table S-3: Releasable Charge Limited System	6	Step 4 - Refrigerant Piping Connections	20
Table S-3: Explanation of symbols displayed on the indoor unit or outdoor unit	10	Fig. 4-1: Correct Pipe Cutting	20
Specifications	11	Fig. 4-2: Reamer Tool.....	20
Table SP-1: Connection Guide	11	Fig. 4-3: Copper pipe and flare nut	21
Fig. SP-1: Multi-Zone Example Setup	11	Fig. 4-4: Flare Form	21
Product Overview	12	Fig. 4-5: Flare Shape	21
Fig. PO-1: Wall Mounted Type.....	12	Table 4-2: Flare Dimensions/Tightening Torque.....	21
Fig. PO-2: Duct/Ceiling Type	12	Fig. 4-6: Align the center of the two pipes.....	21
Fig. PO-3: Floor Console Type	13	Fig. 4-7: Torque wrench with backup wrench.....	21
Fig. PO-4: Compact 4-Way Cassette Type	13	Fig. 4-8: Bend the Tubing	22
Fig. PO-5: 1-Way Cassette Type	13	Step 5 - Power Wiring Connections.....	22
Installation Diagram	14	Fig. 5-1: Wiring Overview	22
Installation Accessories	15	Fig. 5-2: Remove Electrical Cover	23
Table A-1: Included Accessories.....	15	Fig. 5-3: High Voltage Power Connections.....	23
Table A-2: Connecting Pipe Specificaitons*.....	15	Fig. 5-4: One-Three Models.....	24
Unpacking The Unit	15	Fig. 5-5: One-Four Models.....	24
Operating Conditions.....	15	Fig. 5-6: One-Five Models	25
Table A-2: Operating Ambient Temperatures.....	15	Fig. 5-7: One-Six Models	25
Dimensions	16	Step 6 - Air Evacuation	26
Table D-1: Dimensions.....	16	Fig. 6-1: Manifold Gauge Arrangement.....	26
Figure D-1: Unit Dimensions	16	Fig. 6-2: Service Valve.....	26
Clearances	17	Fig. 6-3: Valve Check Pionts.....	27
Fig. C-1: Clearance Dimensions.....	17	Table 6-1: Additional Refrigerant Formula.....	27
Fig. C-2: Clearance for Annual Snowfall.....	17	Start-Up	27
Fig. C-3: Clearances for Multiple Units.....	17	Automatic Wiring/Piping Correction	28
Table C-1: Rows of series installation.....	17	Fig. PW-1: Piping/Wiring Connections.....	28
Installation Requirements	17	Operation Instructions	29
Installation	18	Manual Operations and Maintenance	30
Step 1 - Check Equipment.....	18	Troubleshooting	31
Step 2 - Mount Unit.....	18	Table T-1: Common Issues	31
Fig. 2-1: High Wind Installation	18	Table T-2: When To Call For Repairs	32

Safety Considerations

WARNING

Hazards or unsafe practices that may result in severe personal injury or death.

CAUTION

Hazards or unsafe practices may result in minor personal injury or property damage. Carefully follow the precautions because they are essential to guarantee the safety of the equipment.

NOTE

A property-damage-only hazard, meaning no personal injury is possible.

IMPORTANT

Is used to highlight suggestions which will result in enhanced installation, reliability, or operation.

WARNING

State of California Proposition 65 Warning (US Only)

This product contains chemicals known to the State of California to cause cancer, birth defects, or other reproductive harm.

WARNING

Improper installation, adjustment, alteration, service, maintenance, or use can cause an explosion, fire, electrical shock, or other conditions that may cause death, personal injury, or property damage. Consult a qualified installer, service agency, distributor, or branch for information or assistance. The qualified installer or agency must use factory-authorized kits or accessories when modifying this product. Refer to the individual instructions packaged with kits or accessories when installing.

IMPORTANT

Follow all safety codes. Wear safety glasses, protective clothing, and work gloves. Have a fire extinguisher available. Read these instructions thoroughly and follow all warnings or cautions in the literature and labels attached to the unit. Consult local building codes and the current editions of the National Electrical Code (NEC) NFPA 70.

IMPORTANT

In Canada, refer to the current editions of the Canadian Electrical Code CSA C22.1. Follow the safety information.

WARNING

This appliance is not intended for use by persons (including children) with reduced physical, sensory or mental capabilities, or lack of experience and knowledge, unless they have been given supervision or instruction concerning use of the appliance by a person responsible for their safety. Children should be supervised to ensure that they do not play with the appliance.

WARNING

ELECTRICAL WARNINGS

- Only use the specified wire. If the wire is damaged, it must be replaced by the manufacturer, its service agent, or similarly qualified persons to avoid a hazard.
- The product must be properly grounded during installation, or electric shock may occur.
- For all electrical work, follow all local and national wiring standards, regulations, and the Installation Manual. Connect cables tightly, and clamp them securely to prevent external forces from damaging the terminal. Improper electrical connections can overheat, cause fire, and cause shock. All electrical connections must be made according to the Electrical Connection Diagram located on the panels of the indoor and outdoor units.
- All wiring must be properly arranged to ensure that the control board cover can close properly. If the control board cover is not closed properly, it can lead to corrosion and cause the connection points on the terminal to heat up, catch fire, or cause electrical shock.
- External disconnect shall be incorporated in installed wiring as per national and local codes.
- **Do not** share the electrical outlet with other appliances. Improper or insufficient power supply can cause fire or electric shock.
- If connecting power to installed wiring, an all-pole disconnect device that has at least 3 mm clearances in all poles, and have a leakage current that may exceed 10 mA, the residual current device (RCD) having a rated residual operating current not exceeding 30 mA, and disconnection must be incorporated into the installed wiring following the wiring rules.

WARNING

ELECTRICAL SHOCK HAZARD

Failure to follow this warning could result in personal injury or death. Before installing, modifying, or servicing the system, the main electrical disconnect switch must be in the OFF position. There may be more than one disconnect switch. Lock out and tag the switch with a suitable warning label.



WARNING

EXPLOSION HAZARD

Failure to follow this warning could result in death, serious personal injury, and/or property damage.

Never use air or gases containing oxygen for leak testing or operating refrigerant compressors. Pressurized mixtures of air or gases containing oxygen can lead to an explosion.



⚠ CAUTION

EQUIPMENT DAMAGE HAZARD

Failure to follow this caution may result in equipment damage or improper operation. Do not bury more than 36 in. (914 mm) of refrigerant pipe in the ground. If any section of pipe is buried, there must be a 6 in. (152 mm) vertical rise to the valve connections on the outdoor units. If more than the recommended length is buried, the refrigerant may migrate to the cooler buried section during extended periods of system shutdown. This causes refrigerant slugging and could damage the compressor at start-up.



PRODUCT INSTALLATION

⚠ WARNING

- Turn off the air conditioner and disconnect the power before performing any installation or repair. Failure to do so can cause electric shock.
- An authorized dealer or specialist must perform the installation. Defective installation can cause water leakage, electrical shock, or fire.
- Installation must be performed according to the installation instructions.
- Improper installation can cause water leakage, electrical shock, or fire.
- Contact an authorized service technician for repair or maintenance of this unit.
- That the appliance shall be installed in accordance with national wiring regulations;
- Only use the included accessories, parts, and specified parts for installation.
- Using non-standard parts can cause water leakage, electrical shock, and fire, and can cause the unit to fail.
- Install the unit in a firm location that can support the unit's weight. If the chosen location cannot support the unit's weight, or the installation is not done properly, the unit may drop and cause serious injury and damage.
- Install drainage piping according to the instructions in this manual. Improper drainage may cause water damage to your home and property.
- For units that have an auxiliary electric heater, do not install the unit within 1 m (3 ft.) of any combustible materials.
- For the units that have a wireless network function, the USB device access, replacement, and maintenance operations must be carried out by professional staff.
- **Do not** install the unit in a location that may be exposed to combustible gas leaks. If combustible gas accumulates around the unit, it may cause fire.
- **Do not** turn on the power until all work has been completed.
- When moving or relocating the air conditioner, consult experienced service technicians for disconnecting and reinstallation of the unit.
- How to install the appliance to its support, please read the information for details in "indoor unit installation" and "outdoor unit installation" sections.

TAKE NOTE OF FUSE SPECIFICATIONS

The air conditioner's circuit board (PCB) is designed with a fuse to provide overcurrent protection. The specifications of the fuse are printed on the circuit board, for example, T3.15 AL/250 VAC, T5 AL/250 VAC, T3.15 A/250 VAC, T5A/250 VAC, T20 A/250 VAC, T30 A/250VAC, etc.

NOTE

Only the blast-proof ceramic fuse can be used.

⚠ WARNING

CLEANING AND MAINTENANCE

- Turn off the device and disconnect the power before cleaning. Failure to do so can cause electrical shock.
- **Do not** clean the air conditioner with excessive amounts of water.
- **Do not** clean the air conditioner with combustible cleaning agents. Combustible cleaning agents can cause fire or deformation.

⚠ WARNING

USING FLAMMABLE REFRIGERANT

1. Installation (Space)
 - That the installation of pipe work shall be kept to a minimum.
 - That pipe work shall be protected from physical damage.
 - Where refrigerant pipes shall comply with national gas regulations.
 - That mechanical connections shall be accessible for maintenance purposes.
 - In cases that require mechanical ventilation, ventilation openings shall be kept clear of obstruction.
 - When disposing of the used product, it must be based on national regulations, and properly processed.
2. Service
 - Any person who is involved with working on or breaking into a refrigerant circuit should hold a currently valid certificate from an industry-accredited assessment authority, which authorizes their competence to handle refrigerants safely following an industry-recognized assessment specification.
3. Maintenance and repair requiring the assistance of other skilled personnel shall be carried out under the supervision of a person competent in the use of flammable refrigerants.
4. Do not use means to accelerate the defrosting process or to clean, other than those recommended by the manufacturer.
5. The appliance shall be stored in a room without continuously operating ignition sources (for example: open flames, an operating gas appliance, or an operating electric heater).
6. Be careful that foreign matter(oil, water,etc) does not enter the piping. Also, when storing the piping, securely seal the opening by pinching, taping, etc.
7. Do not pierce or burn.
8. Be aware that refrigerants may not contain an odor.
9. All working procedures that affect safety means shall only be carried out by competent technicians.

10. Appliance shall be stored in a well-ventilated area where the room size corresponds to the room area as specified for operation.
11. The appliance shall be stored to prevent mechanical damage from occurring.
12. Joints shall be tested with detection equipment with a capability of 0.2 oz./year of refrigerant or better, with the equipment in standstill and under operation or pressure of at least these standstill or operation conditions after installation. Detachable joints shall NOT be used in the indoor side of the unit (brazed, welded joints could be used).

For R454B refrigerant charge amount and minimum room area:

Requirements for room area limits using R454B refrigerant in unventilated areas: Our multiple systems are all confirmed to meet the requirement of Enhanced Tightness Refrigerating Systems. Units installed at a height not exceeding 5.9 ft./1.8 m above the ground are usually equipped with refrigerant sensors, which minimum room area (A_{min}) of operating or storage should be determined according to min refrigerant charge (m_c) or releasable charge (m_{rel}) of system, as specified in the rel following table. The table is also applicable for those units without refrigerant sensors but its installation heights are between 5.9 ft./1.8 m and 7.2 ft./2.2 m. The height of the room cannot be less than 7.2 ft./2.2 m.

Table S-1: Minimum Room Area Requirements

m_c or m_{rel} [oz./kg]	A_{min} [ft. ² /m ²]	m_c or m_{rel} [oz./kg]	A_{min} [ft. ² /m ²]
≤62.7/1.776	12/1.10	119.9/3.4	112/10.44
63.5/1.8	60/5.53	127/3.6	119/11.06
70.5/2.0	66/6.14	134/3.8	126/11.67
77.6/2.2	73/6.76	141.1/4.0	132/12.29
84.6/2.4	79/7.37	148.1/4.2	139/12.9
91.7/2.6	86/7.99	155.2/4.4	145/13.51
98.8/2.8	93/8.6	162.2/4.6	152/14.13
105.8/3.0	99/9.21	169.3/4.8	159/14.74
112.9/3.2	106/9.83	176.4/5.0	165/15.36

Units installed higher than 7.2 ft./2.2 m have a looser installation area requirement, as specified in the following table.

Table S-2: Minimum Room Area Requirements

A_{min} [ft. ² /m ²]	h_{inst} [ft/m]				
m_c or m_{REL} [oz/kg]	7.5/2.3	7.9/2.4	8.5/2.6	9.2/2.8	9.8/3.0
≤62.7/1.776	12/1.10				
63.5/1.8	57/5.29	55/5.07	50/4.68	47/4.34	44/4.05
70.5/2	63/5.88	61/5.63	56/5.2	52/4.83	48/4.5
77.6/2.2	70/6.46	67/6.19	62/5.72	57/5.31	53/4.95
84.6/2.4	76/7.05	73/6.76	67/6.24	62/5.79	58/5.41
91.7/2.6	82/7.64	79/7.32	73/6.76	67/6.27	63/5.86
98.8/2.8	89/8.23	85/7.88	78/7.28	73/6.76	68/6.31
105.8/3	95/8.81	91/8.45	84/7.8	78/7.24	73/6.76
112.9/3.2	101/9.4	97/9.01	90/8.32	83/7.72	78/7.21
119.9/3.4	107/9.99	103/9.57	95/8.84	88/8.2	82/7.66
127/3.6	114/10.58	109/10.14	101/9.36	94/8.69	87/8.11
134/3.8	120/11.16	115/10.7	106/9.88	99/9.17	92/8.56
141.1/4	126/11.75	121/11.26	112/10.4	104/9.65	97/9.01
148.1/4.2	133/12.34	127/11.82	117/10.91	109/10.14	102/9.46
155.2/4.4	139/12.93	133/12.39	123/11.43	114/10.62	107/9.91
162.2/4.6	145/13.51	139/12.95	129/11.95	119/11.1	111/10.36
169.3/4.8	152/14.1	145/13.51	134/12.47	125/11.58	116/10.81
176.4/5	158/14.69	152/14.08	140/12.99	130/12.07	121/11.26
Notes	<p>A_{min} is the required minimum room area in ft. 2 -> ft.²/m² M_c is the actual refrigerant charge in the system in oz/kg M_{REL} is the refrigerant releasable charge in oz./kg h_{inst} is the height of the bottom of the appliance relative to the floor of the room after installation. WARNING: The minimum room area or minimum room area of conditioned space is based on releasable charge and total system refrigerant charge.</p>				

NOTE

If the actual room size does not fit the abovementioned conditions, please refer to the upper-level condition. Ex. we provide suggestions for a room size of 400 sq. ft., if the room size is 450 sq. ft., please refer to the 500 sq. ft. requirement.

For releasable charge limited system::

SAFETY SHUT-OFF VALVES are used in some multiple outdoor units, as shown in the following table, for the purposes of limiting the releasable charge, which is activated by the refrigerant detection system.

⚠ WARNING

SAFETY SHUT-OFF VALVES default to the fully closed position when the appliance is de-energized, so refrigerant will not be completely released even when it is dismantled. Ensure the complete release of refrigerant through one of the following methods before repairing the machine.
 Method 1: Release the refrigerant while the machine is powered on.
 Method 2: Remove the coil of the safety shut-off valve before power-off.
 Method 3: Manually open the safety shut-off valve using a magnetic ring.

Table S-3: Releasable Charge Limited System

Model	Outdoor Unit	Releasable Charge Limited System
18K Regular	M03EX-H18B-2A	No
18K Extreme Heat	M03HX-H18B-2A	No
27K Regular	M04EX-H27B-2A	No
27K Extreme Heat	M04HX-H27B-2A	No
36K Regular	M05EX-H36B-2A	No
36K Extreme Heat	M05HX-H36B-2A	No
48K Regular	M06EX-H48B-2A	No
48K Extreme Heat	M06HX-H48B-2A	No
60K Regular	M06EX-H60B-2A	No
60K Extreme Heat	M06HX-H60B-2A	No

The releasable charge (m_{rel}) of the system should be calculated based on the internal rel volume of all indoor units and connecting pipes. Each indoor unit corresponds to a releasable charge as following table, add them up based on the combination of indoor units, and then add to the basic releasable charge of 7.196 oz./0.204 kg, and you will get the total releasable charge of the system.

NOTE

The calculation is based on the standard connection pipe length of 24.6 ft./7.5 m for each indoor unit, an extra releasable charge should be added per meter exceeding 24.6 ft./7.5 m.

If the calculated releasable charge (m_{rel}) is higher than the refrigerant charge (m_c), the room area shall be calculated based on the refrigerant charge (m_c).

1. Installation

- Any person who is involved with working on or breaking into a refrigerant circuit should hold a current valid certificate from an industry-accredited assessment authority, which authorizes their competence to handle refrigerants safely in accordance with an industry-recognized assessment specification.
- Maintenance and repair requiring the assistance of other skilled personnel shall be carried out under the supervision of the person competent in the use of flammable refrigerants.
- That the installation of pipe work shall be kept to a minimum.
- That pipe work shall be protected from physical damage.
- Where refrigerant pipes shall comply with national gas regulations.
- That mechanical connections shall be accessible for maintenance purposes.
- Be careful that foreign matter (oil, water, etc.) does not enter the piping. Also, when storing the piping, securely seal the opening by pinching, taping, etc.
- All working procedures that affect safety means shall only be carried out by competent technicians.
- Appliance shall be stored in a well-ventilated area where the room size corresponds to the room area as specified for operation.
- Joints shall be tested with detection equipment with a capability of 0.2 oz./year of refrigerant or better, with the equipment in a standstill and under operation or

under pressure of at least these standstill or operation conditions after installation. Detachable joints should NOT be used on the indoor side of the unit (brazed, welded joints could be used).

- In cases that require mechanical ventilation, ventilation openings shall be kept clear of obstruction.
- LEAK DETECTION SYSTEM installed. The unit must be powered except for service.
- For the unit with a refrigerant sensor, when the refrigerant sensor detects refrigerant leakage, the indoor unit will display an error code and emit a buzzing sound, the compressor of the outdoor unit will immediately stop, and the indoor fan will start running. The service life of the refrigerant sensor is 15 years. When the refrigerant sensor malfunctions, the indoor unit will display the error code "FHCC".
- The refrigerant sensor cannot be repaired and can only be replaced by the manufacturer. It shall only be replaced with the sensor specified by the manufacturer.

2. When a FLAMMABLE REFRIGERANT is used, the requirements for installation space of appliance and/or ventilation requirements are determined according to

- the mass charge amount(M) used in the appliance,
- the installation location,
- the type of ventilation of the location or the appliance.
- piping material, pipe routing, and installation shall include protection from physical damage in operation and service, and comply with national and local codes and standards, such as ASHRAE 15, IAPMO Uniform Mechanical Code, ICC International Mechanical Code, or CSA B52. All field joints shall be accessible for inspection before being covered or enclosed.
- that protection devices, piping, and fittings shall be protected as far as possible against adverse environmental effects, for example, the danger of water collecting and freezing in relief pipes or the accumulation of dirt and debris;
- that piping in refrigeration systems shall be so designed and installed to minimize the likelihood of hydraulic shock damaging the system;
- that steel pipes and components shall be protected against corrosion with a rustproof coating before applying any insulation;
- that precautions shall be taken to avoid excessive vibration or pulsation;
- the minimum floor area of the room shall be mentioned in the form of a table or a single figure without reference to a formula;
- after completion of field piping for split systems, the field pipework shall be pressure tested with an inert gas and then vacuum tested before refrigerant charging, according to the following requirements:
 - a. The minimum pressure test for the low side of the system shall be the low side design pressure and the minimum pressure test for the high side of the system shall be the high side design pressure, unless the high side of the system can not be isolated from the low side of the system in which case the entire system shall be pressure tested to the low side design pressure.

- b. During the pressure test, the system shall maintain the pressure for at least 1 h with no decrease of pressure indicated by the test gauge, with test gauge resolution not exceeding 5% of the test pressure.
- c. During the evacuation test, after achieving a vacuum level specified in the manual or less, the refrigeration system shall be isolated from the vacuum pump and the pressure shall not rise above 1500 microns within 10 min. The vacuum pressure level shall be specified in the manual and shall be the lesser of 500 microns or the value required for compliance with national and local codes and standards, which may vary between residential, commercial, and industrial buildings.
 - field-made refrigerant joints indoors shall be tightness tested according to the following requirements: The test method shall have a sensitivity of 5 grams per year of refrigerant or better under a pressure of at least 0,25 times the maximum allowable pressure. No leak shall be detected.

3 . Qualification of workers

Any maintenance, service, and repair operations must require the qualification of the working personnel. Every working procedure that affects safety means shall only be carried out by competent technicians who joined the training and achieved competence should be documented by a certificate. The training of these procedures is carried out by national training organizations or manufacturers that are accredited to teach the relevant national competency standards that may be set in legislation. All training shall follow the ANNEX HH requirements of UL 60335-2-40 4th Edition. Examples of such working procedures are:

- breaking into the refrigerating circuit;
- opening of sealed components;
- opening of ventilated enclosures.

4. Checks to the area

Before beginning work on systems containing flammable refrigerants, safety checks are necessary to ensure that the risk of ignition is minimized. For repair to the refrigerating system, the following precautions shall be complied with before conducting work on the system.

5. Work procedure

Works shall be undertaken under a controlled procedure to minimize the risk of flammable gas or vapor being present while the work is being performed.

6. General work area

All maintenance staff and others working in the local area should be instructed on the nature of the work being carried out. Work in confined spaces shall be avoided.

7. Checking for the presence of refrigerant

The area should be checked with an appropriate refrigerant detector before and during work, to ensure the technician is aware of potentially flammable atmospheres. Ensure that the leak detection equipment being used is suitable for use with flammable refrigerants, i.e. no sparking, adequately sealed or intrinsically safe.

8. Presence of fire extinguisher

If any hot work is to be conducted on the refrigeration equipment or any associated parts, appropriate fire extinguishing equipment shall be available to hand. Have a dry powder or CO₂ fire extinguisher adjacent to the charging area.

9. No ignition sources

No person carrying out work on a REFRIGERATING SYSTEM which involves exposing any pipe work shall use any sources of ignition in such a manner that it may lead to the risk of a fire or explosion. All possible ignition sources, including cigarette smoking, should be kept sufficiently far away from the site of installation, repair, removal, and disposal, during which refrigerant can be released into the surrounding space. Before work takes place, the area around the equipment is to be surveyed to make sure that there are no flammable hazards or ignition risks. "No Smoking" signs shall be displayed.

10. Ventilated area

Ensure that the area is in the open or that it is adequately ventilated before breaking into the system or conducting any hot work. A degree of ventilation shall continue during the period that the work is carried out. The ventilation should safely disperse any released refrigerant and preferably expel it externally into the atmosphere.

11. Check the refrigeration equipment

Where electrical components are being changed, they shall be fit for the purpose and to the correct specification. At all times the manufacturer's maintenance and service guidelines shall be followed. If in doubt consult the manufacturer's technical department for assistance. The following checks shall be applied to installations using FLAMMABLE REFRIGERANTS:

- the actual refrigerant charge is in accordance with the room size within which the refrigerant-containing parts are installed;
- the ventilation machinery and outlets are operating adequately and are not obstructed;
- if an indirect refrigerating circuit is being used, the secondary circuits shall be checked for the presence of refrigerant;
- marking to the equipment continues to be visible and legible, marking and illegible signs shall be corrected;
- refrigeration pipe or components are installed in a position where they are unlikely to be exposed to any substance that may corrode refrigerant-containing components unless the components are constructed of materials that are inherently resistant to being corroded or are suitably protected against being so corroded.

12. Checks to electrical devices

Repair and maintenance of electrical components shall include initial safety checks and component inspection procedures. If a fault exists that could compromise safety, then no electrical supply shall be connected to the circuit until it is satisfactorily dealt with. If the fault cannot be corrected immediately it is necessary to continue operation, and adequate temporary solution shall be used.

This shall be reported to the owner of the equipment so

all parties are advised.

Initial safety checks shall include:

that capacitors are discharged: this shall be done safely to avoid the possibility of sparking;

that no live electrical components and wiring are exposed while charging, recovering, or purging the system;

that there is continuity of earth bonding;

Sealed electrical components shall be replaced if it's damaged; Intrinsically safe components must be replaced if it's damaged.

13. Cabling

Check that cabling will not be subject to wear, corrosion, excessive pressure, vibration, sharp edges, or any other adverse environmental effects. The check shall also take into account the effects of aging or continual vibration from sources such as compressors or fans.

14. Detection of flammable refrigerants

Under no circumstances shall potential sources of ignition be used in the search for or detection of refrigerant leaks. A halide torch(or any other detector using a naked flame) shall not be used.

The following leak detection methods are deemed acceptable for refrigerant systems. Electronic leak detectors may be used to detect refrigerant leaks but, in the case of FLAMMABLE REFRIGERANTS, the sensitivity may not be adequate, or may need re-calibration. (Detection equipment shall be calibrated in a refrigerant-free area.) Ensure that the detector is not a potential source of ignition and is suitable for the refrigerant used. Leak detection equipment shall be set at a percentage of the LFL of the refrigerant and shall be calibrated to the refrigerant employed, and the appropriate percentage of gas (25 % maximum) is confirmed. Leak detection fluids are also suitable for use with most refrigerants but the use of detergents containing chlorine shall be avoided as the chlorine may react with the refrigerant and corrode the copper pipe-work.

NOTE

Examples of leak-detection fluids are

- bubble method,
- fluorescent method agents.

If a leak is suspected, all naked flames shall be removed/ extinguished.

If leakage of refrigerant is found which requires brazing, all of the refrigerant shall be recovered from the system, or isolated (using shut-off valves) in a part of the system remote from the leak. See the following instructions for the removal of refrigerant.

15. Removal and evacuation

When breaking into the refrigerant circuit to make repairs - or for any other purpose conventional procedures shall be used. However, for flammable refrigerants best practice must be followed since flammability is a consideration.

The following procedure shall be adhered to:

- safely remove refrigerant following local and national regulations;
- evacuate;
- purge the circuit with inert gas;

- evacuate;
- continuously flush or purge with inert gas when using a flame to open the circuit; and
- open the circuit.

The refrigerant charge shall be recovered into the correct recovery cylinders if venting is not allowed by local and national codes. For appliances containing flammable refrigerants, the system shall be purged with oxygen-free nitrogen to render the appliance safe for flammable refrigerants. This process might need to be repeated several times. Compressed air or oxygen shall not be used for purging refrigerant systems.

For appliances containing flammable refrigerants, refrigerant purging shall be achieved by breaking the vacuum in the system with oxygen-free nitrogen and continuing to fill until the working pressure is achieved, then venting to the atmosphere, and finally pulling down to a vacuum. This process shall be repeated until no refrigerant is within the system. When the final oxygen-free nitrogen charge is used, the system shall be vented down to atmospheric pressure to enable work to take place.

The outlet for the vacuum pump shall not be close to any potential ignition sources, and ventilation shall be available.

16. Charging procedures

In addition to conventional charging procedures, the following requirements shall be followed:

- Works shall be undertaken with appropriate tools only (In case of uncertainty, please consult the manufacturer of the tools for use with flammable refrigerants) Ensure that contamination of different refrigerants does not occur when using charging equipment. Hoses or lines shall be as short as possible to minimize the amount of refrigerant contained in them.
- Ensure that the refrigeration system is earthed before charging the system with refrigerant.
- Label the system when charging is complete(if not already). Extreme care shall be taken not to overfill the refrigeration system.
- Before recharging the system, it shall be pressure tested with oxygen-free nitrogen (OFN). The system shall be leak tested on completion of charging but before commissioning. A follow-up leak test shall be carried out before leaving the site.

17. Decommissioning

Before carrying out this procedure, the technician must be completely familiar with the equipment and all its details. It is recommended good practice that all refrigerants are recovered safely. Before the task is carried out, an oil and refrigerant sample shall be taken in case analysis is required before the re-use of recovered refrigerant. Electrical power must be available before the task commences.

- a. Become familiar with the equipment and its operation.
- b. Isolate system electrically
- c. Before attempting the procedure ensure that:
 - mechanical handling equipment is available, if required, for handling refrigerant cylinders;
 - all personal protective equipment is available and

- being used correctly;
 - the recovery process is supervised at all times by a competent person;
 - recovery equipment and cylinders conform to the appropriate standards.
- d. Pump down the refrigerant system, if possible.
 - e. If a vacuum is not possible, make a manifold so that refrigerant can be removed from various parts of the system.
 - f. Make sure that the cylinder is situated on the scales before recovery takes place.
 - g. Start the recovery machine and operate following instructions.
 - h. Do not overfill cylinders (no more than 80 % volume liquid charge)
 - i. Do not exceed the maximum working pressure of the cylinder, even temporarily.
 - j. When the cylinders have been filled correctly and the process completed, make sure that the cylinders and the equipment are removed from the site promptly and all isolation valves on the equipment are closed off.
 - k. Recovered refrigerant shall not be charged into another refrigeration system unless it has been cleaned and checked.

18. Labelling

Equipment shall be labeled stating that it has been de-commissioned and emptied of refrigerant. The label shall be dated and signed. For appliances containing FLAMMABLE REFRIGERANTS, ensure that there are labels on the equipment stating the equipment contains FLAMMABLE REFRIGERANT.

19. Recovery

When removing refrigerant from a system, either for servicing or decommissioning, it is recommended good practice that all refrigerants are removed safely.

When transferring refrigerant into cylinders, ensure that only appropriate refrigerant recovery cylinders are employed. Ensure that the correct number of cylinders for holding the total system charge is available. All cylinders to be used are designated for the recovered refrigerant and labeled for that refrigerant (i. e. special cylinders for the recovery of refrigerant). Cylinders shall be complete with pressure-relief valves and associated shut-off valves in good working order. Empty recovery cylinders are evacuated and, if possible, cooled before recovery occurs.

The recovery equipment shall be in good working order with a set of instructions concerning the equipment that is at hand and shall be suitable for the recovery of the flammable refrigerant. If in doubt, the manufacturer should be consulted. In addition, a set of calibrated weighing scales shall be available and in good working order. Hoses shall be complete with leak-free disconnect couplings and in good condition.

The recovered refrigerant shall be processed according to local legislation in the correct recovery cylinder, and the relevant waste transfer note arranged. Do not mix refrigerants in recovery units especially not in cylinders. If compressors or compressor oils are to be removed,

ensure that they have been evacuated to an acceptable level to make certain that flammable refrigerant does not remain within the lubricant. The compressor body shall not be heated by an open flame or other ignition sources to accelerate this process. When oil is drained from a system, it shall be carried out safely.

20. Transportation, marking, and storage for units that employ flammable refrigerants

- a. **General** - The following information is provided for units that employ FLAMMABLE REFRIGERANTS.
- b. **Transport of equipment containing flammable refrigerants** - Attention is drawn to the fact that additional transportation regulations may exist concerning equipment containing flammable gas. The maximum number of pieces of equipment or the configuration of the equipment permitted to be transported together will be determined by the applicable transport regulations.

- c. **Marking of equipment using signs** - Signs for similar appliances used in a work area are generally addressed by local regulations and give the minimum requirements for the provision of safety and/or health signs for a work location.

All required signs are to be maintained, and employers should ensure that employees receive suitable and sufficient instruction and training on the meaning of appropriate safety signs and the actions that need to be taken in connection with these signs.

The effectiveness of signs should not be diminished by too many signs being placed together.

Any pictograms used should be as simple as possible and contain only essential details.

- d. **Disposal of equipment using flammable refrigerants**
See national regulations.

- e. **Storage of equipment/appliances** - The storage of the appliance should be following the applicable regulations or instructions, whichever is more stringent.

- f. **Storage of packed (unsold) equipment** - Storage package protection should be constructed in such a way that mechanical damage to the equipment inside the package will not cause a leak of the REFRIGERANT CHARGE.

The maximum number of pieces of equipment permitted to be stored together will be determined by local regulations.





21. Unventilated areas

- An unventilated area where the appliance using FLAMMABLE REFRIGERANTS is installed shall be so constructed that should any refrigerant leak, it will not stagnate to create a fire or explosion hazard.

- If appliances are connected via an air duct system to one or more rooms with A2L REFRIGERANTS are installed in a room with an area less than A_{min} , that room shall be without continuously operating open flames (e.g. an operating gas appliance) or other POTENTIAL IGNITION SOURCES (e.g. an operating electric heater, hot surfaces). A flame-producing device may be installed in the same space if the device is provided with an effective flame arrest.

- Auxiliary devices that may be a POTENTIAL IGNITION SOURCE shall not be installed in the ductwork. Examples of such POTENTIAL IGNITION SOURCES are hot surfaces with a temperature exceeding 700 °C and electric switching devices.
- Only auxiliary devices (such as certificated heater kit) approved by the appliance manufacturer or declared suitable with the refrigerant shall be installed in connecting ductwork.
- For duct-connected appliances, false ceilings or drop ceilings may be used as a return air plenum if a REFRIGERANT DETECTION SYSTEM is provided in the appliance and any external connections are also provided with a sensor immediately below the return air plenum duct joint.
- REFRIGERANT SENSORS for REFRIGERANT DETECTION SYSTEMS Shall Only be replaced with sensors specified by the appliance manufacturer.
- LEAK DETECTION SYSTEM installed. The unit must be powered except for service.

Table S-3: Explanation of symbols displayed on the indoor unit or outdoor unit

	<p>WARNING</p>	<p>This symbol shows that this appliance used a flammable refrigerant. If the refrigerant is leaked and exposed to an external ignition source, there is a risk of fire.</p>
	<p>CAUTION</p>	<p>This symbol shows that the operation manual should be read carefully.</p>
	<p>CAUTION</p>	<p>This symbol shows that service personnel should be handling this equipment referencing the installation manual.</p>
	<p>CAUTION</p>	<p>This symbol shows that information is available such as the operating manual or installation manual.</p>

Specifications

Table SP-1: Connection Guide

Number of units that can be used together	Connected units	1-6 units				
Compressor stop/start frequency	Stop time	3 min or more				
Power source voltage	voltage fluctuation	within $\pm 10\%$ of rated voltage				
	voltage drop during start	within $\pm 15\%$ of rated voltage				
	interval unbalance	within $\pm 3\%$ of rated voltage				
Models						Unit: ft./m
		1 drive 2	1 drive 3	1 drive 4	1 drive 5	1 drive 6
Max. length for all rooms		131/40	197/60	262/80	262/80	262/80
Max. length for one indoor unit		82/25	98/30	115/35	115/35	115/35
Max. height different between indoor and outdoor unit		49/15	49/15	49/15	49/15	49/15
Max. height different between indoor units		33/10	33/10	33/10	33/10	33/10

When installing multiple indoor units with a single outdoor unit, ensure that the length of the refrigerant pipe and the drop height between the indoor and outdoor units meet the requirements illustrated in the following diagram:

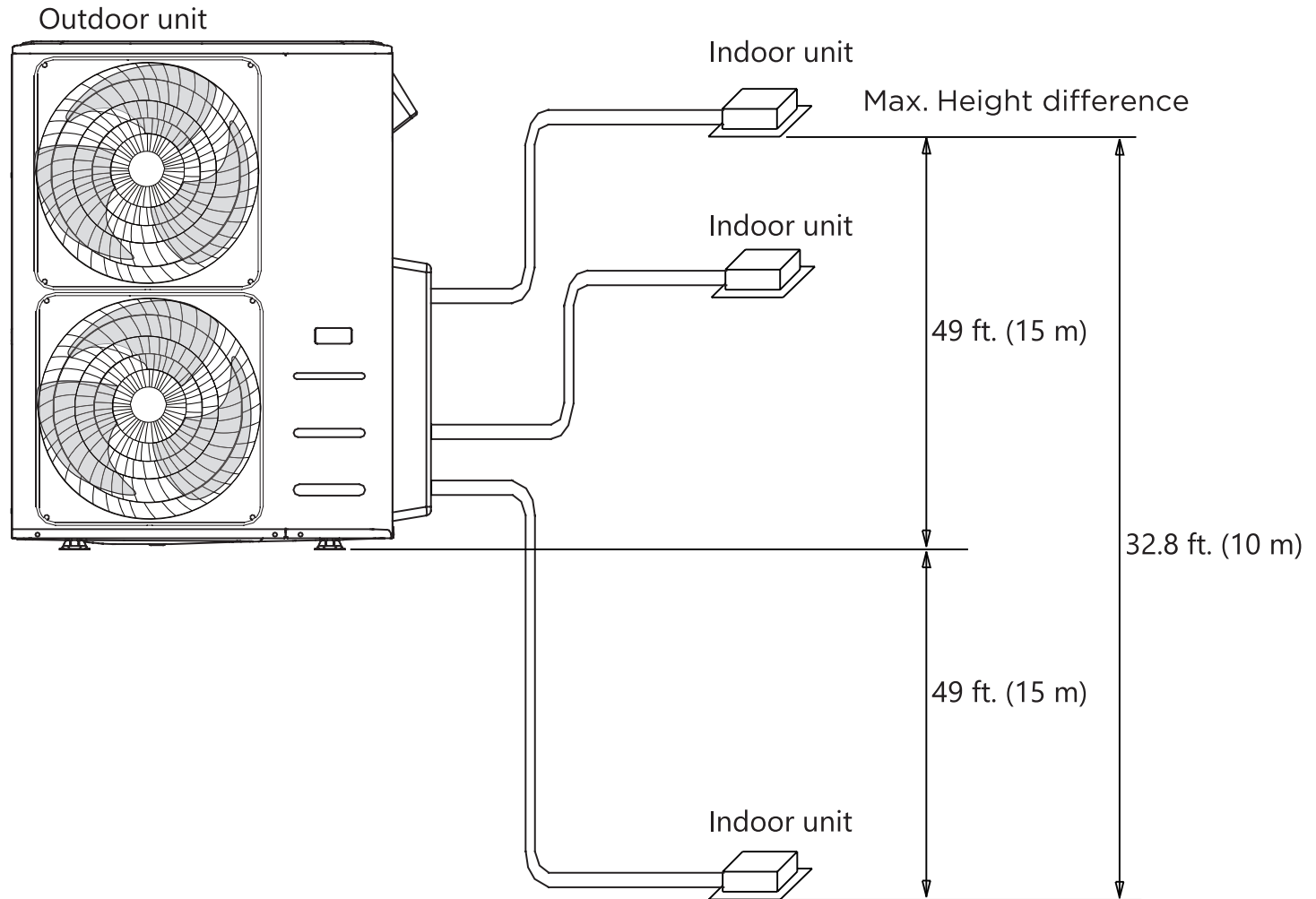

Fig. SP-1: Multi-Zone Example Setup

Product Overview

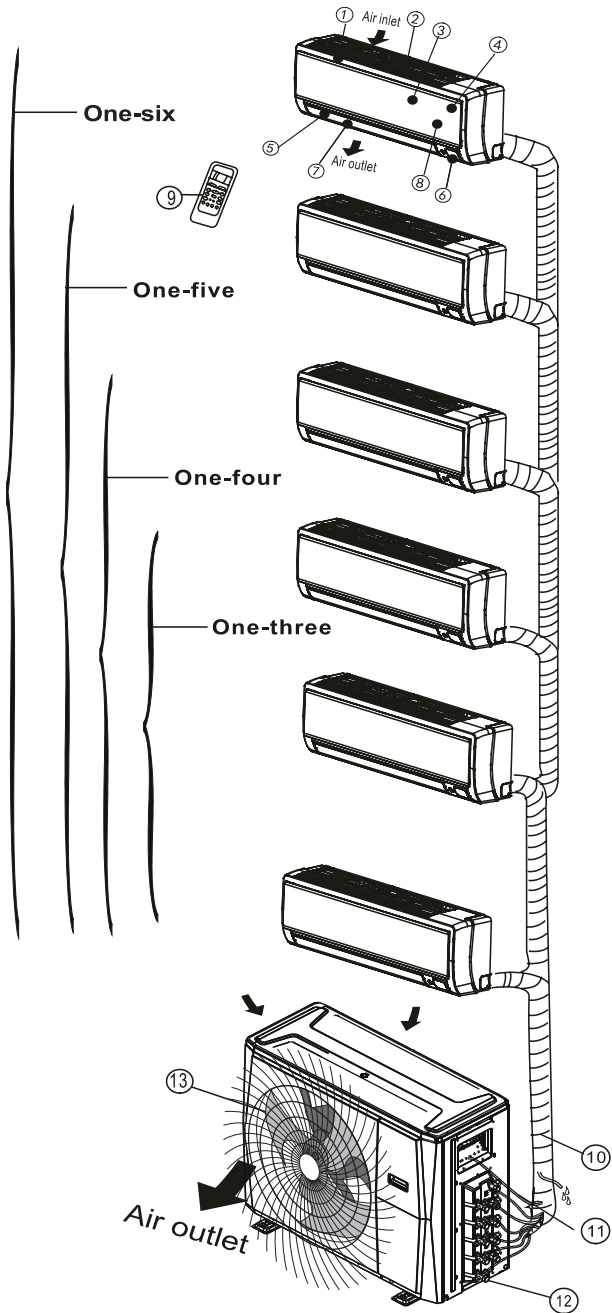

Fig. PO-1: Wall Mounted Type Indoor Unit

1. Panel Frame
2. Rear panel intake grill
3. Front Panel
4. Air purifying filter & Air filter (behind)
5. Horizontal louver
6. LCD display window
7. Vertical louver
8. Manual control button (behind)
9. Remote control

Outdoor Unit

10. Drain hose, refrigerant connecting pipe
11. Connective cable
12. Stop valve
13. Fan hood

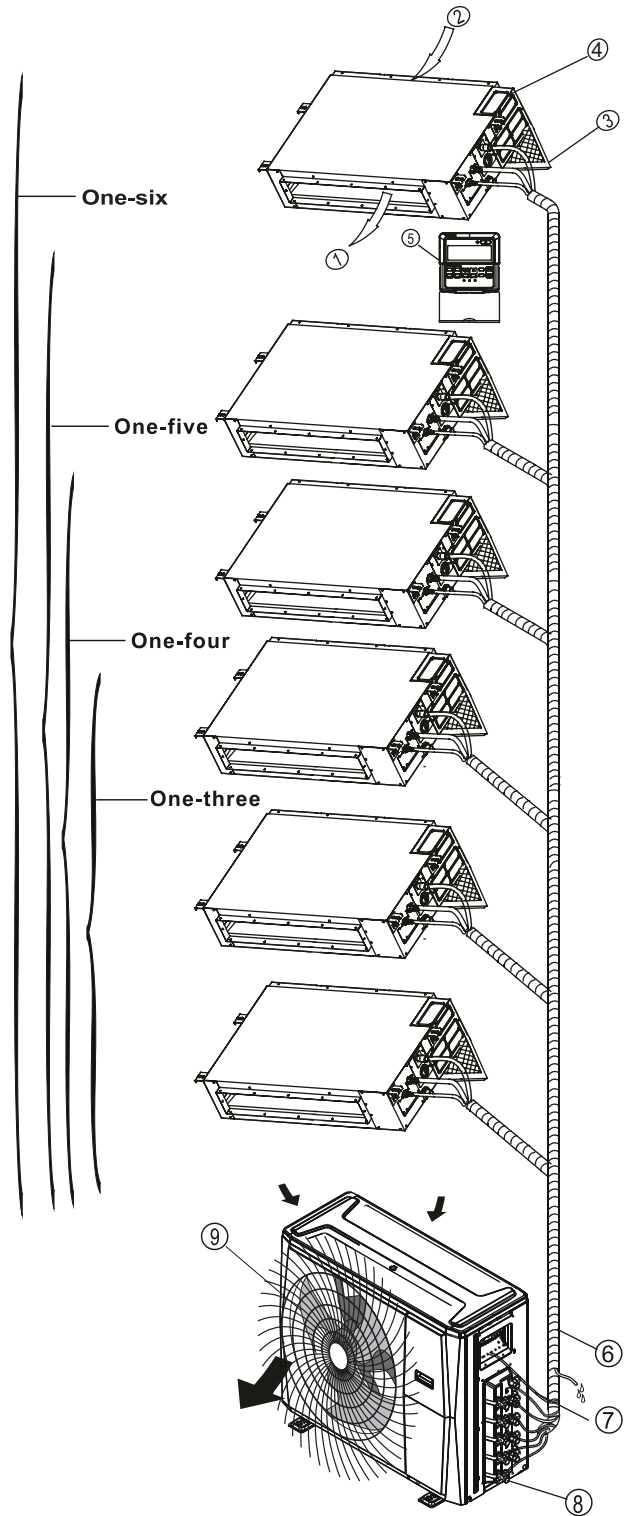

Fig. PO-2: Duct/Ceiling Type Indoor Unit

1. Air outlet
2. Air inlet
3. Air filter
4. Electric control cabinet
5. Wired control

Outdoor Unit

6. Drain hose, refrigerant connecting pipe
7. Connective cable
8. Stop valve
9. Fan hood

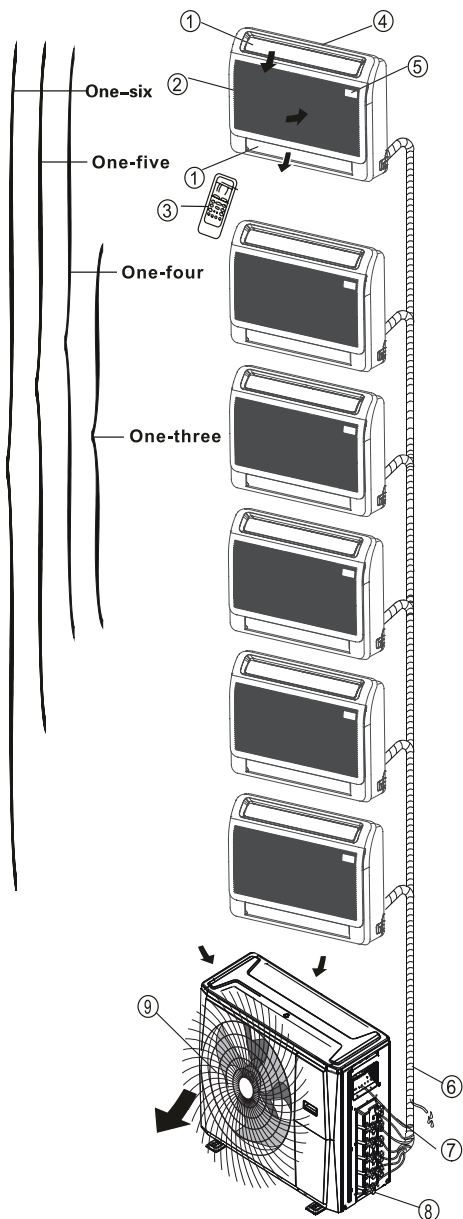

Fig. PO-3: Floor Console Type Indoor Unit

1. Air flow louver (at air outlet)
2. Air inlet
3. Remote control
4. Installation part
5. Display panel

Outdoor Unit

6. Drain hose, refrigerant connecting pipe
7. Connective cable
8. Stop valve
9. Fan hood

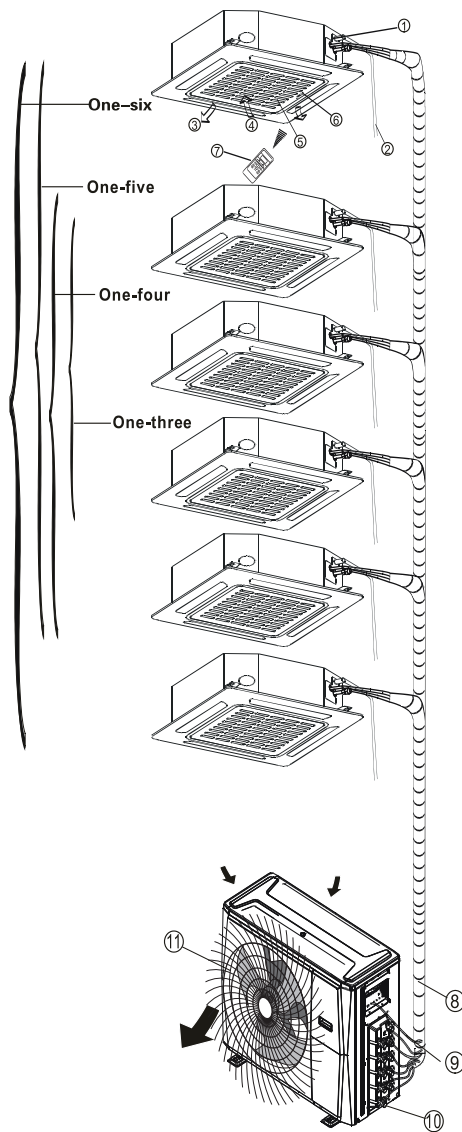

Fig. PO-4: Compact 4-Way Cassette Type

1. Drain pump (drain water from indoor unit)
2. Drain hose
3. Air outlet
4. Air inlet
5. Air-in grill
6. Display panel
7. Remote control

Outdoor Unit

8. Refrigerant connecting piping
9. Connective cable
10. Stop valve
11. Fan hood

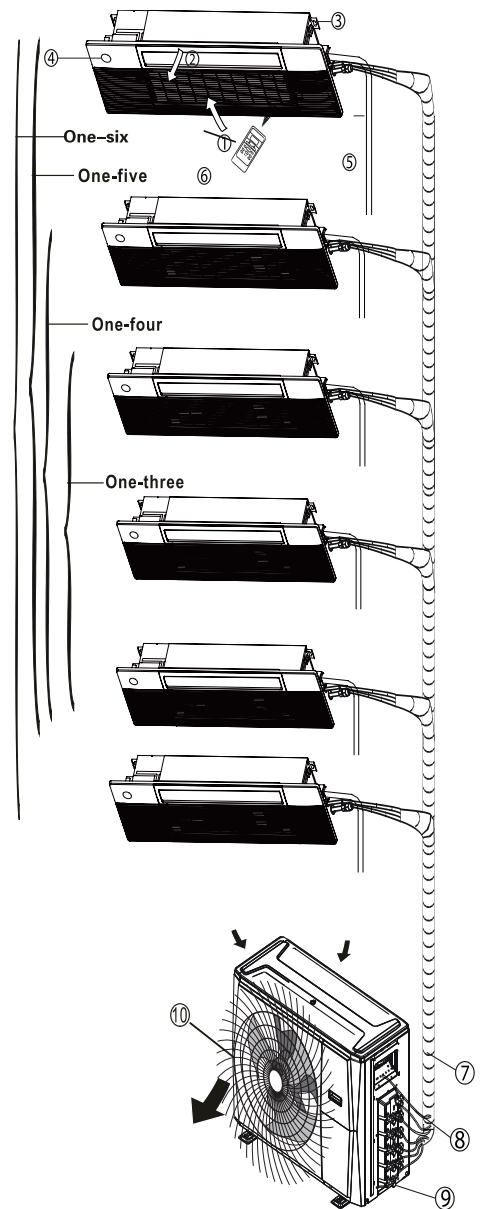

Fig. PO-5: 1-Way Cassette Type

1. Air inlet (with air filter in it)
2. Air flow louver (at air outlet)
3. Installation part
4. Display panel
5. Drain pipe
6. Remote control

Outdoor Unit

7. Refrigerant connecting piping
8. Connective cable
9. Stop valve
10. Fan hood

NOTE

- For multi-split air conditioners, one outdoor unit can be matched to different types of indoor units. The pictures in this manual are for demonstration purposes only. Your air conditioner may be slightly different, if similar in shape.
- It is a necessity to allow disconnection of the appliance from the supply after installation, unless the appliance incorporates a switch complying. The disconnection may be achieved by having the plug accessible or by incorporating a switch in the fixed wiring following the wiring rules.

Installation Diagram

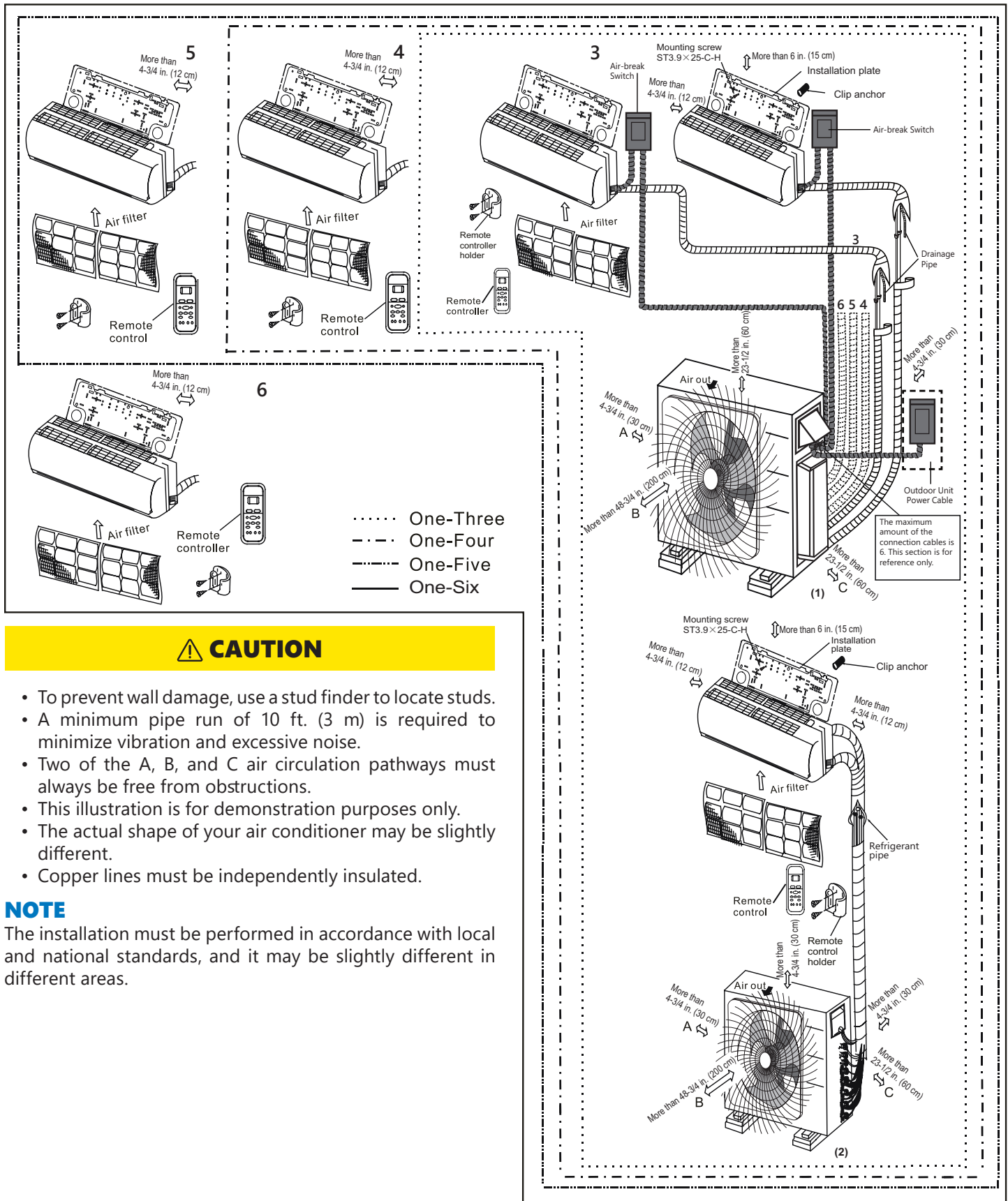

CAUTION

- To prevent wall damage, use a stud finder to locate studs.
- A minimum pipe run of 10 ft. (3 m) is required to minimize vibration and excessive noise.
- Two of the A, B, and C air circulation pathways must always be free from obstructions.
- This illustration is for demonstration purposes only.
- The actual shape of your air conditioner may be slightly different.
- Copper lines must be independently insulated.



NOTE

The installation must be performed in accordance with local and national standards, and it may be slightly different in different areas.

Installation Accessories

The air conditioning system comes with the following accessories: Use all of the installation parts and accessories to install the air conditioner. Improper installation may result in water leakage, electrical shock, fire, or equipment failure. The items not included with the air conditioner must be purchased separately. Keep the installation manual in a safe place and do not discard any other accessories until the installation work has been completed.

Table A-1: Included Accessories

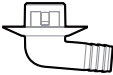
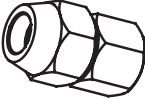
QTY.	Part Name	Part Image
1	Manual	
1	Seal ring (Not available for M05HX-H36B-2A)	
1	Drain Joint	
1-8	Transfer Connector* (Optional Part)	

NOTE

*Pipe sizes may differ from appliance to appliance. To meet different pipe size requirements, pipe connections sometimes need a transfer connector installed on the outdoor unit.

Optional Accessories

There are two types of remote controls: wired and wireless. Select a remote control based on customer preferences and requirements and install it in an appropriate place. Refer to catalogs and technical literature for guidance on selecting a suitable remote control.

Table A-2: Connecting Pipe Specifications*

Unit: inches (mm)

Model	Line Side	Gas Side
6K/9K/12K	Ø1/4 in. (Ø6.35)	Ø3/8 in. (Ø9.52)
18K	Ø1/4 in. (Ø6.35)	Ø1/2 in. (Ø12.7)
24K/30K/33K/36K	Ø3/8 in. (Ø9.52)	Ø5/8 in. (Ø15.9)

NOTE

*Parts you must purchase separately. Consult the dealer about the proper pipe size of the unit you purchased.

Unpacking The Unit

1. Cut the packing belt.
2. Take the unit out of the package.
3. Remove the foam from the unit.
4. Remove the packing film from the unit.

Operating Conditions

When your air conditioner is used outside of the following temperature ranges, certain safety protection features may activate and cause the unit to disable.

Table A-2: Operating Ambient Temperatures

	COOL Mode	HEAT Mode	DRY Mode
Room Temp.	60°F~90°F (16°C~32°C)	32°F~86°F (0°C~30°C)	50°F~90°F (10°C~32°C)
Outdoor Temp.	-13°F~122°F (-25°C~50°C)	-13°F~75°F (-25°C~24°C)	32°F~122°F (0°C~50°C)
	-22°F~122°F (-30°C~50°C)*	-22°F~75°F (-30°C~24°C)*	

*For Extreme Heat models

For Outdoor Units With Auxiliary Electric Heater

When the outside temperature is below 32°F (0°C), we strongly recommend keeping the unit always plugged in to ensure smooth ongoing performance.

NOTE

The room's relative humidity should be less than 80%. If the air conditioner operates more than this figure, its surface may attract condensation. Please set the vertical air flow louver to its maximum angle (vertically to the floor) and set the fan to HIGH.

To further optimize the performance of your unit, do the following:

- Keep doors and windows closed.
- Limit energy usage by using TIMER ON and TIMER OFF functions.
- Do not block air inlets or outlets.
- Regularly inspect and clean air filters.

Dimensions

Table D-1: Dimensions

Model	Unit Sizes			Mounting Dimensions	
	Width (W) in. (mm)	Depth (D) in. (mm)	Height (H) in. (mm)	(A) in. (mm)	(B) in. (mm)
M03EX-H18B-2A	35 (890)	13-1/2 (342)	26-1/2 (673)	26-1/10 (663)	13-9/10 (354)
M03HX-H18B-2A M04HX-H27B-2A M04EX-H27B-2A M05EX-H36B-2A	37-1/4 (946)	16-1/8 (410)	31-7/8 (810)	25-1/2 (673)	15-8/10 (403)
M05HX-H36B-2A	38-1/2 (978)	16-1/3 (415)	38-3/8 (975)	24-1/4 (616)	15-5/8 (397)
M06HX-H48B-2A M06HX-H60B-2A M06EX-H48B-2A M06EX-H60B-2A	37-1/2 (952)	16-1/3 (415)	52-1/2 (1333)	25 (634)	15-9/10 (404)

Figure D-1: Unit Dimensions

NOTE

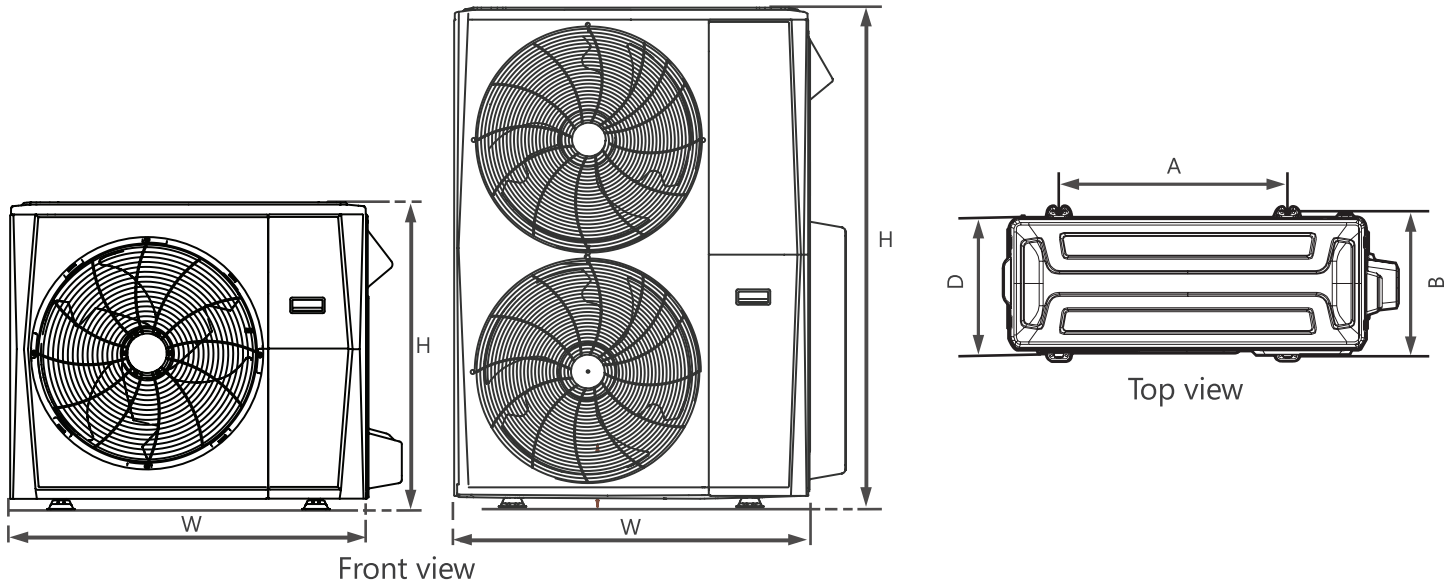

Images are for illustration purposes only. Actual models may differ slightly.

Clearances

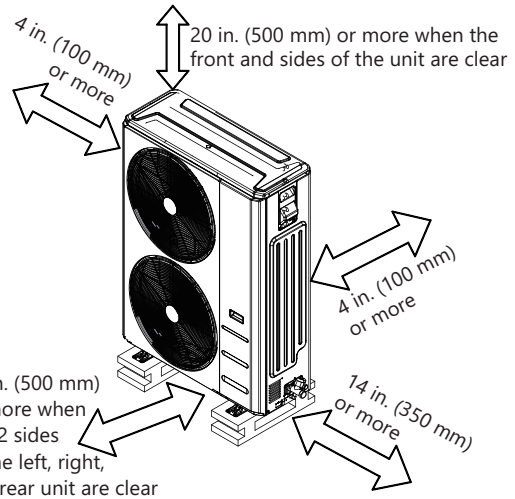
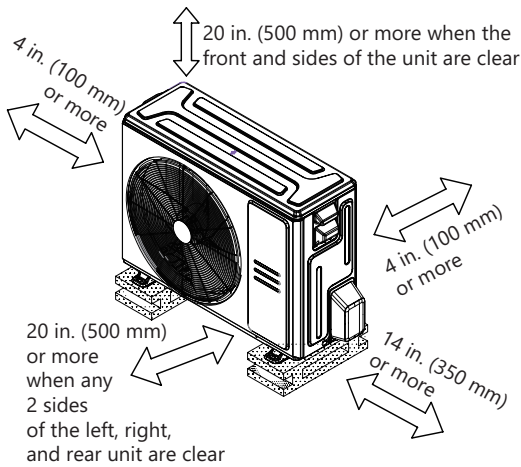

Fig. C-1: Clearance Dimensions

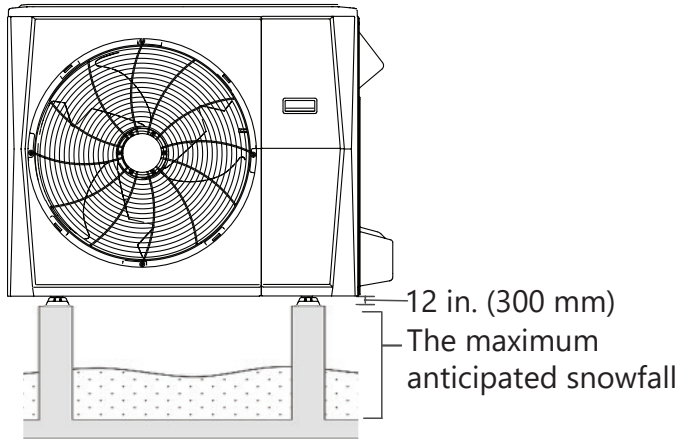

Fig. C-2: Clearance for Annual Snowfall

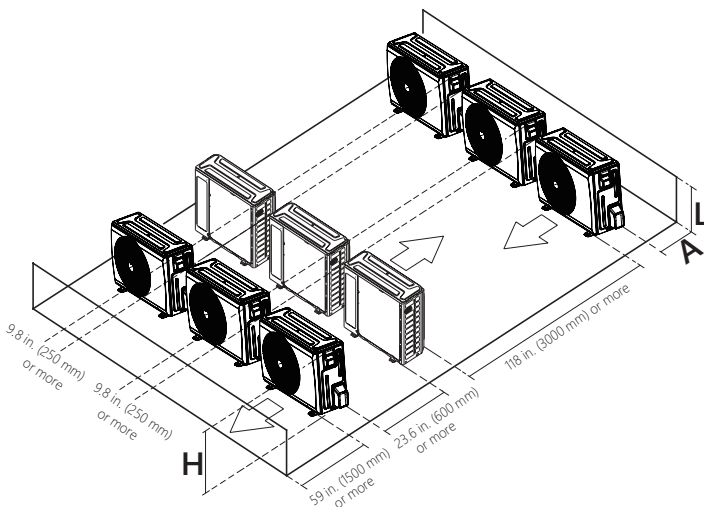

Fig. C-3: Clearances for Multiple Units

NOTE

The outdoor unit must be mounted at least 11.8 in. (300 mm) above the maximum anticipated snow fall

CAUTION

EQUIPMENT DAMAGE HAZARD

Failure to follow this caution may result in equipment damage or improper operation. In regions with snowfall and cold temperatures, avoid installing the outdoor unit in areas where it can be covered by snow.



Blocking the air intake may result in reduced airflow, significantly reduced performance, and damage to the equipment.

Table C-1: Rows of series installation

The relations between H, A, and L are as follows.

	L	A
L ≤ H	L ≤ 1/2 H	9-8/10 in. (250 mm) or more
	1/2 H < L ≤ H	11-8/10 in. (300mm) or more
L > H	Cannot be installed	

Installation Requirements

Install the unit(s) in the following areas:

✓ A location that is convenient for installation and not exposed to strong winds.

✓ A location that can bear the weight of the outdoor unit and where the outdoor unit can be mounted in a level position.

✓ A location which provides appropriate clearances (see Fig. C-1).

✓ Allow sufficient space for airflow and service of the



unit. See Fig. C-3 for the required minimum distances between the unit or walls.

✓ Protected from prolonged periods of direct sunlight or rain.



✓ Where snowfall is anticipated, take appropriate measures to prevent ice buildup and coil damage. See Fig. C2 for snowfall clearances.



NOTE

DO NOT install the unit in the following locations:

- ✓ Near an obstacle that will block air inlets and outlets.
- ✓ In a location that is exposed to large amounts of dust.
- ✓ With special environmental conditions.
- ✓ Near animals or plants that will be harmed by hot air discharge.
- ✓ Near any source of combustible gas
- ✓ Near a public street, crowded areas, or where noise from the unit will disturb others.



WARNING

PRODUCT INSTALLATION

- Installation must be performed by an authorized dealer or specialist. A defective installation can cause water leakage, electrical shock, or fire.
- The installation must be performed according to the installation instructions. Improper installation can cause water leakage, electrical shock, or fire. (In North America, installation must be performed in accordance with the requirements of NEC or CEC by authorized personnel only.)
- Contact an authorized service technician for repair or maintenance of this unit. This appliance must be installed in accordance with local codes.
- Only use the included accessories, parts, and specified parts for installation. Using non-standard parts can cause water leakage, electrical shock, fire, or unit failure.
- To prevent exposure to wind, install the outdoor unit with its air inlet side facing the wall
- Install drainage piping according to the instructions in this manual. Improper drainage may cause water damage to your home and property.
- **DO NOT** install the unit in a location that may be exposed to combustible gas leaks. If combustible gas accumulates around the unit, it may cause a fire.
- **DO NOT** turn on the power until all work has been completed.
- When moving or relocating the system, consult experienced service technicians for the disconnection and re-installation of the unit.

Installation

Step 1 - Check Equipment

Unpack the unit and move it to the final location. Remove the carton, taking care not to damage the unit. Inspect the equipment for damage before installation. File a claim with the shipping company if the shipment is damaged or incomplete.

Locate the unit rating plate which contains the proper installation information. Check the rating plate to ensure the unit matches the job specifications.

Step 2 - Mount Unit

CAUTION

SPECIAL CONSIDERATIONS FOR EXTREME WEATHER

If the unit is exposed to heavy wind:

Install the unit so that the air outlet fan is at a 90° angle to the direction of the winds. See Fig. 2-1.

If the unit is exposed to heavy rain or snow:

Build a shelter above the unit to protect it from rain or snow. Be careful to not obstruct airflow around the unit.

1. Select the installation location of the outdoor unit following the installation requirements. To prevent high wind exposure, install the outdoor unit with the air inlet side facing the wall (see Fig. 2-1).

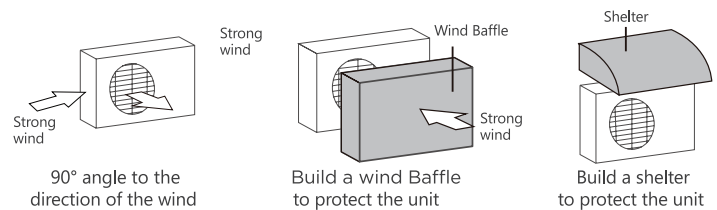

Fig. 2-1: High Wind Installation

2. Use a rigid base to support the unit in a level position. If conditions or local codes require the unit to be attached to a pad, tie-down bolts should be used and fastened through knockouts provided in the unit base pan. For hurricane tie downs, contact the distributor for details and PE (Professional Engineer) Certification if required.

GROUND INSTALLATION

1. Mark the positions for four expansion bolts based on the dimensions chart
2. Pre-drill holes for expansion bolts.
3. Place a nut on the end of each expansion bolt.
4. Hammer expansion bolts into the pre-drilled holes.
5. Remove the nuts from the expansion bolts and place the outdoor unit on the bolts.
6. Put the washer on each expansion bolt, then replace the nuts.
7. Using a wrench, tighten each nut until snug.

WARNING

When drilling into concrete, eye protection is recommended at all times.

WALL INSTALLATION

1. Mark the position of bracket holes based on the dimensions chart.
2. Pre-drill the holes for the expansion bolts. Place a washer and nut on the end of each expansion bolt.
3. Thread expansion bolts through holes in mounting brackets, put mounting brackets in position, and hammer expansion bolts into the wall.
4. Check that the mounting brackets are level. Carefully lift the unit and place its mounting feet on brackets.
5. Bolt the unit firmly to the brackets.
6. If allowed, install the unit with rubber isolator pads to reduce vibrations and noise.

⚠ CAUTION

Make sure that the wall is made of solid brick, concrete, or similarly strong material. The wall must be able to support at least four times the weight of the unit.

Drilling Hole in the Wall for the Indoor Unit

You must drill a hole in the wall for the refrigerant piping, and the signal cable that will connect the indoor and outdoor units.

1. Determine the wall hole's location based on the outdoor unit's location.
2. Using a 2.5in (65mm) core drill, drill a hole in the wall.

NOTE

When drilling the wall hole, make sure to avoid wires, plumbing, and other sensitive components.

3. Place the protective wall cuff in the hole. This protects the edges of the hole and helps seal it when you finish the installation process.

When Installing 24K/30K/33K/36K Indoor Unit

The 24K/30K/33K/36K indoor unit can only be connected with an A system. If there are two 24K/30K/33K/36K indoor units, they can be connected with A and B systems.

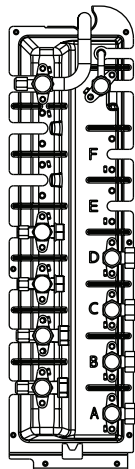

Fig. 2-2: A B System Connection

Step 3 - Install Drain Joint

Before bolting the outdoor unit in place, you must install the drain joint at the bottom of the unit.

Note that there are two different types of drain joints depending on the type of outdoor unit. **If the drain joint**

Multi-Zone Outdoor Unit

comes with a rubber seal. See Fig. 3-1 (A), do the following:

1. Fit the rubber seal on the end of the drain joint that will connect to the outdoor unit.
2. Insert the drain joint into the hole in the base pan of the unit.
3. Rotate the drain joint 90° until it clicks in place facing the front of the unit.
4. Connect a drain hose extension (not included) to the drain joint to redirect water from the unit during heating mode.

If the drain joint doesn't come with a rubber seal. See Fig. 3-1 (B), do the following:

1. Insert the drain joint into the hole in the base pan and press firmly to ensure it is properly installed and will not become loose.
2. Connect a drain hose extension (not included) to the drain joint to redirect water from the unit during heating mode.
3. Rotate the drain joint 90° until it clicks in place facing the front of the unit.
4. Connect a drain hose extension (not included) to the drain joint to redirect water from the unit during heating mode.

NOTE

The installation of drains must comply with local sanitation codes.

Fig. 3-1: Drain Joint Assembly

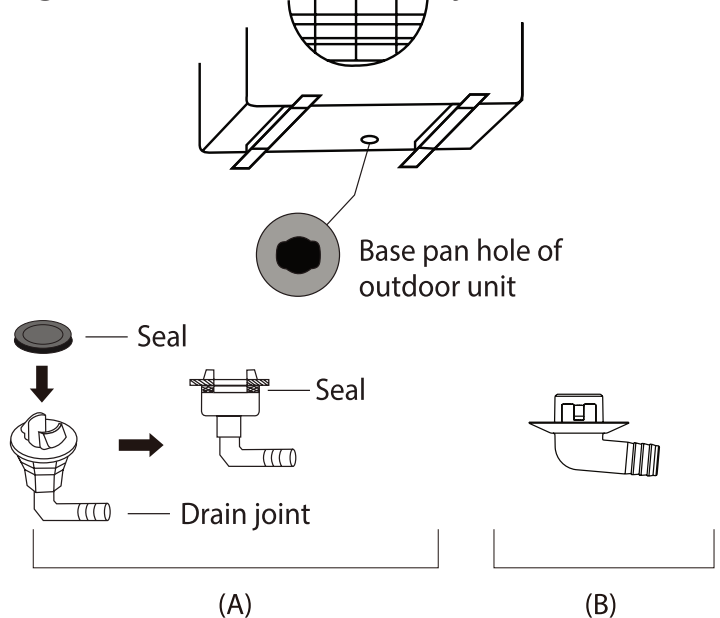

NOTE

Images are for illustration purposes only.

⚠ CAUTION

IN COLD CLIMATES

In cold climates, make sure that the drain hose is as vertical as possible to ensure swift water drainage. If water drains too slowly, it can freeze in the hose and flood the unit.



Step 4 - Refrigerant Piping Connections

When connecting refrigerant piping, **DO NOT** let substances or gases other than the specified refrigerant enter the unit. The presence of other gases or substances will lower the unit's capacity and can cause abnormally high pressure in the refrigeration cycle. This can cause an explosion and injury.

IMPORTANT

Use refrigeration grade tubing **ONLY**. No other type of tubing may be used. The use of other types of tubing will void the manufacturer's warranty.

- Do not open the service valves or remove the protective caps from the tubing ends until all connections are made.
- Bend the tubing with bending tools to avoid kinks and flat spots.
- Keep the tubing free of dirt, sand, moisture, and other contaminants to avoid damaging the refrigerant system.
- Purge the pipes with nitrogen to remove dirt and moisture.
- Insulate the suction line with a minimum of 3/8 in. (10 mm) wall thermal pipe insulation. Inserting the tubing into the insulation before making the connections will save time and improve installation quality.

⚠ WARNING

All field piping must be completed by a licensed technician and must comply with local and national regulations.

When the system is installed in a small room, measures must be taken to prevent the refrigerant concentration in the room from exceeding the safety limit in the event of refrigerant leakage. If the refrigerant leaks and its concentration exceeds its proper limit, hazards due to lack of oxygen may result.

When installing the refrigeration system, ensure that air, dust, moisture, or foreign substances do not enter the refrigerant circuit. Contamination in the system may cause poor operating capacity, high pressure in the refrigeration cycle, explosion, or injury.

Ventilate the area immediately if there is refrigerant leakage during the installation.

Leaked refrigerant gas is hazardous. Ensure there is no refrigerant leakage after completing the installation work.

⚠ CAUTION

DO NOT install the connecting pipe until both the indoor and outdoor units have been installed.

Insulate the suction line to prevent condensation.

Use the following steps to connect the refrigerant piping:

1. Run the interconnecting piping from the outdoor unit to the indoor unit.
2. Connect the refrigerant piping and drain line outside the indoor unit. Complete the pipe insulation at the flare connection then fasten the piping and wiring to the wall as required. Completely seal the hole in the wall.
3. Cut the tubing to the correct length.

When preparing refrigerant pipes, take extra care to cut and flare them properly. This ensures efficient operation and minimizes the need for future maintenance.

- a. Measure the distance between the indoor and outdoor units.
- b. Using a pipe cutter, cut the pipe a little longer than the measured distance.
- c. Make sure the pipe is cut at a perfect 90° angle.

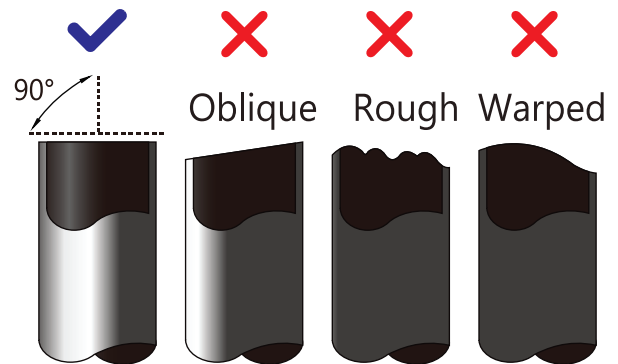

Fig. 4-1: Correct Pipe Cutting

⚠ CAUTION

DO NOT DEFORM PIPE WHILE CUTTING

Be extra careful not to damage, dent, or deform the pipe while cutting. This will drastically reduce the heating efficiency of the unit.

4. Remove the Burrs

Burrs can affect the air-tight seal of the refrigerant piping connection. Therefore, they must be completely removed. To remove:

- a. Hold the pipe at a downward angle to prevent burrs from falling into the pipe.
- b. Using a reamer or deburring tool, remove all burrs from the cut section of the pipe

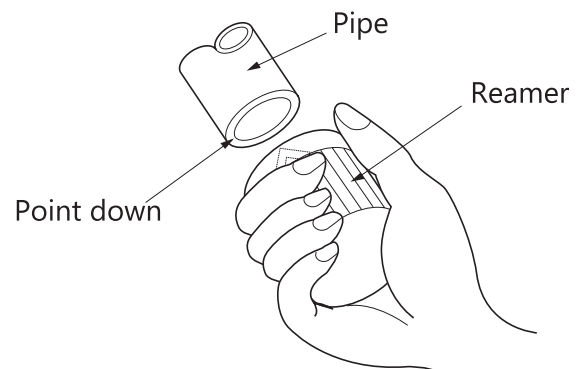

Fig. 4-2: Reamer Tool

5. Flare the Pipe Ends.

Proper flaring is essential to achieving an airtight seal.

- a. After removing the burrs from the cut pipe, seal the ends with PVC tape to prevent foreign materials from entering the pipe.
- b. Sheath the pipe with insulating material.

- c. Place the factory flare nut on the pipe facing the proper direction. Make sure they are facing the right direction. Once the ends are flared, it is impossible to put them on or change their direction.

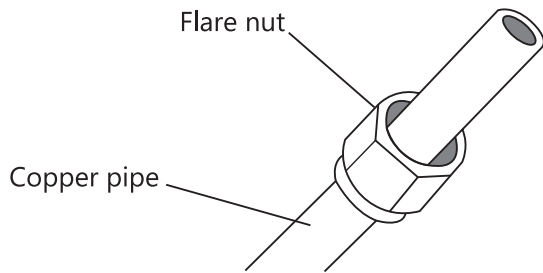

Fig. 4-3: Copper pipe and flare nut

- d. Remove the PVC tape from the ends of the pipe when ready to perform the flaring work.
e. Clamp the flare block on the end of the pipe. The end of the pipe must extend beyond the flare form.

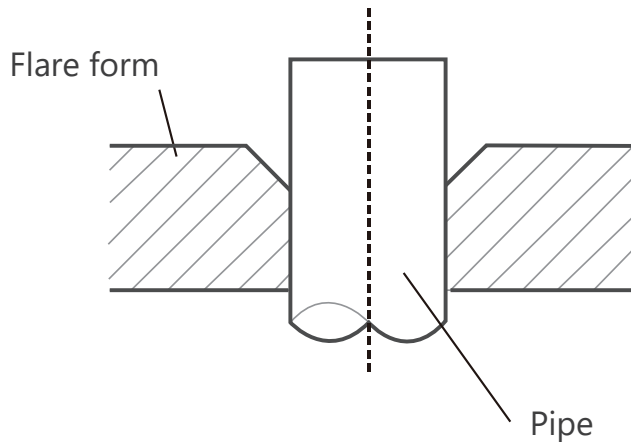

Fig. 4-4: Flare Form

- f. Place the flaring tool onto the form.
g. Turn the handle of the flaring tool clockwise until the pipe is fully flared. Flare the pipe following the dimensions in Table 4-2.

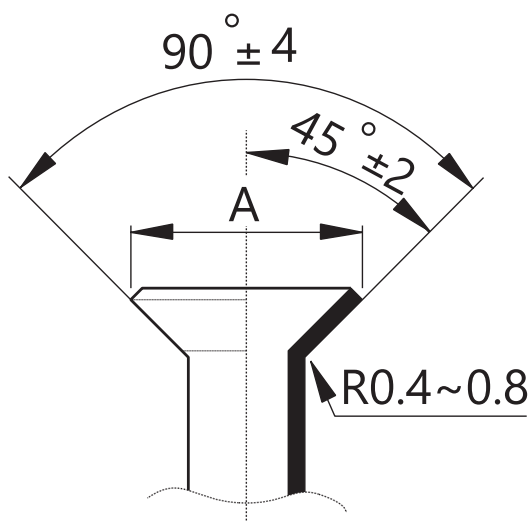

Fig. 4-5: Flare Shape

Table 4-2: Flare Dimensions/Tightening Torque

Pipe Size Outside Diameter	Flare Dimensions (A)
in. (mm)	in. (mm)
Ø1/4 (6.35)	11/23 - 23/64 (~9.1)
Ø3/8 (9.52)	1/2 - 33/64 (~13.2)
Ø1/2 (12.7)	41/64 - 31/32 (~16.6)
Ø5/8 (15.88)	49/64 - 35/32 (~19.7)

Tightening Torque for Flare Nuts

Pipe Size Outside Diameter	Tightening Torque
in. (mm)	ft. - lbs.
Ø1/4 (6.35)	13.0 - 18.0
Ø3/8 (9.52)	24.6 - 30.4
Ø1/2 (12.7)	39.8 - 47.7
Ø5/8 (16)	45.4 - 59.3

NOTE

Use both a backup wrench and a torque wrench when connecting or disconnecting pipes to or from the unit.

- h. Remove the flaring tool and flare block, then inspect the end of the pipe for cracks and even flaring.

6. Connect the Pipes

Connect the copper pipes to the indoor unit first, then connect the pipes to the outdoor unit. Connect the low-pressure pipe first, then connect the high-pressure pipe.

- a. Align the center of the two pipes that you will connect.

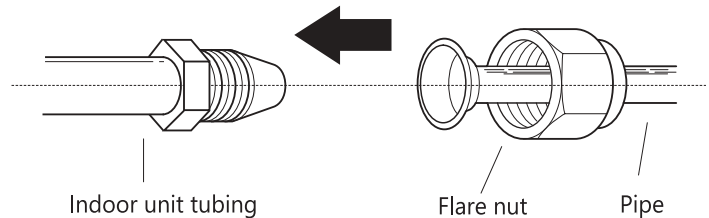

Fig. 4-6: Align the center of the two pipes

- b. Tighten the flare nut as much as possible by hand.
c. Using a wrench, grip the nut on the unit tubing.
d. While firmly gripping the nut, use a torque wrench to tighten the flare nut according to the torque values listed in Table 4-2.

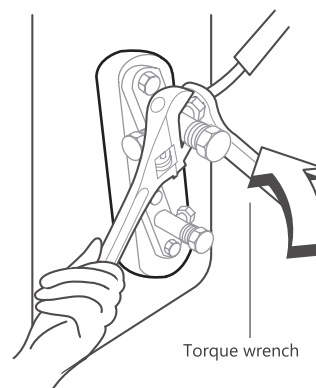

Fig. 4-7: Torque wrench with backup wrench

⚠ CAUTION

Wrap insulation around the piping. Direct contact with the bare piping may result in burns or frostbite. Ensure the pipe is properly connected. Over-tightening may damage the bell mouth and under-tightening may lead to leakage.

All tubing bends should be performed with a properly sized tubing bender to prevent kinking or damaging the tubing.

- e. While firmly gripping the nut, use a torque wrench to tighten the flare nut according to the torque values listed in Table 4-2.

NOTE

MINIMUM BEND RADIUS

Carefully bend the tubing in the middle according to the diagram below. **DO NOT** bend the tubing over 90° or more than 3 times. Use care when bending pipe, do not kink pipe.

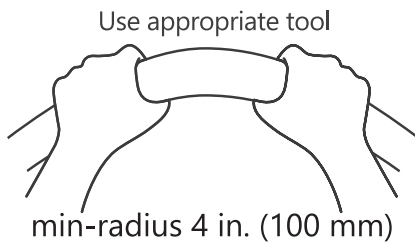

Fig. 4-8: Bend the Tubing

NOTE

While bundling these items together, **DO NOT** intertwine or cross the signal cable with any other wiring.

- f. Thread this line set through the wall and connect it to the outdoor unit.
- g. Insulate the suction line, including the outdoor unit valves.

NOTE

DO NOT open the service valves until the pressure test is complete.

7. Brazing Adapter (Optional)

When flare to braze adapter is used, follow these steps:

- a. Refer to the liquid line and gas line connection O.D. sizes in Table 4-2 based on the model being installed. Cut and deburr the tubing (review "Remove the Burrs" in Step 4) to prepare it for brazing. Set up the nitrogen apparatus and connect it to the outside unit to flow nitrogen while brazing. Braze the tubing and any fittings to obtain a proper seal.
- b. Insulate the suction line completely, including the outdoor unit valves.

Step 5 - Power Wiring Connections

⚠ WARNING

BEFORE PERFORMING ANY ELECTRICAL WORK, READ THESE WARNINGS.

- If there is a serious safety issue with the power supply, stop work immediately. Explain your reasoning to the client, and refuse to install the unit until the safety issue is properly resolved.
- Power voltage should be within 90-110% of rated voltage. Insufficient power supply can cause malfunction, electrical shock, or fire.
- Installation of an external surge suppressor at the outdoor disconnect is recommended.
- Power must be connected, a switch or circuit breaker that disconnects all poles and has a contact separation of at least 1/8 in. (3 mm) must be incorporated into the fixed wiring. The qualified technician must use an approved circuit breaker or switch.
- Only connect the unit to an individual branch circuit. Do not connect another appliance to that circuit.
- Make sure to properly ground the air conditioner.
- Every wire must be firmly connected. Loose wiring can cause the terminal to overheat, resulting in product malfunction and possible fire.
- Do not let wires touch or rest against refrigerant tubing, the compressor, or any moving parts within the unit.
- To avoid getting an electric shock, never touch the electrical components soon after the power supply has been turned off. After turning off the power, always wait 10 minutes or more before you touch the electrical components.
- **ISOLATE THE POWER SUPPLY LEADS AND COMMUNICATION LEADS BY THE STRAIN RELIEF AND KEEP POWER SUPPLY LEADS AWAY FROM COMMUNICATION LEADS.**
- Connect the outdoor wires before connecting the indoor wires.

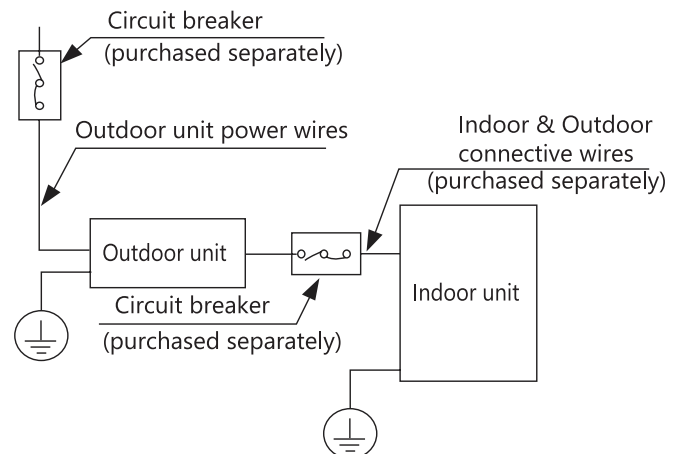

Fig. 5-1: Wiring Overview

NOTE

- When connecting the wires, strictly follow the wiring diagram found inside the electrical box cover.
- Choose the cable type according to the local electrical switches and regulations.
- Please choose the right cable size according to the Minimum Circuit Ampacity indicated on the nameplate of the unit. Refer to the nameplate to choose the right cable, fuse, or switch.

NOTE

Circuit Breaker

When the maximum current of the air conditioner is more than 16 A, a circuit breaker or leakage protection switch with protective device shall be used (purchased separately). When the maximum current of the air conditioner is less than 16 A, the power cord of air conditioner shall be equipped with plug (purchased separately). In North America, the appliance should be wired according to NEC and CEC requirements.

WARNING

BEFORE PERFORMING ANY ELECTRICAL OR WIRING WORK, TURN OFF THE MAIN POWER TO THE SYSTEM. Install All Power and Interconnecting Wiring to Outdoor Units

1. Mount the outdoor power disconnect.
2. Run the power wiring from the main box to disconnect per NEC or CEC and local codes.
3. Remove the field wiring cover from the unit by loosening the screws.
4. Using wire strippers, strip the rubber jacket from both ends of the signal cable to reveal approximately 6 in. (150 mm) of wire.

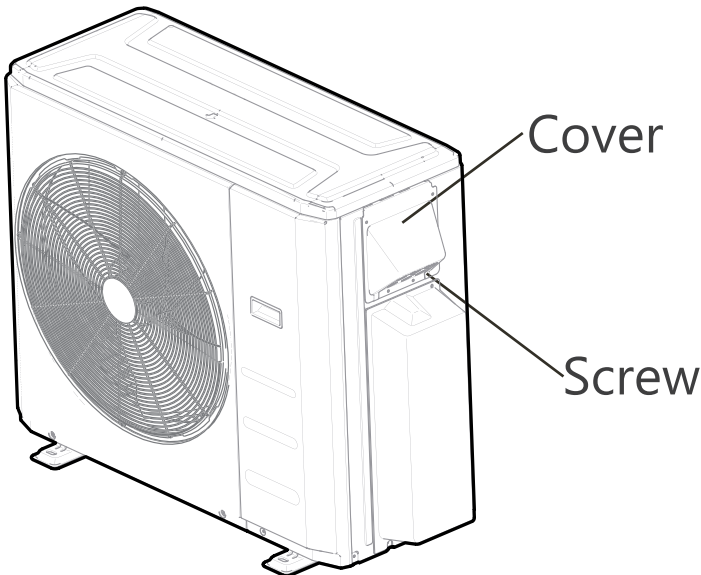

Fig. 5-2: Remove Electrical Cover

5. Using a wire crimper, crimp the U-lugs on the ends.
6. Properly connect both the power supply and control lines to the terminal block per the connection diagram for the appropriate unit capacity and voltage.
7. Connect the U-lugs to the terminals. Match the wire colors/labels with the labels on the terminal block.

Firmly screw the u- lug of each wire to its corresponding terminal.

8. Ground the unit in accordance with NEC or CEC and local electrical codes.
9. Clamp down the cable with the cable clamp.
10. Reinstall the cover of the electric control box.

CAUTION

EQUIPMENT DAMAGE HAZARD

Failure to follow this caution may result in equipment damage or improper operation.

Be sure to comply with local codes while running wire from the indoor unit to the outdoor unit.

Disconnecting means must be provided and shall be located within sight and readily accessible from the air conditioner. The connecting cable with the conduit shall be routed through a hole in the conduit panel.

An approved and listed fitting must be used to securely affix conduit in accordance with NEC and local codes.

Wiring Figures

CAUTION

Connect the connective cables to the terminals, as identified, with their matching numbers on the terminal block of the indoor and outdoor units. For example, Terminal L1 (A) of the outdoor unit must connect with Terminal L1/1 on the indoor unit. The outdoor unit can match different types of indoor units, the numbers on the terminal block of the indoor unit may be slightly different. Please pay special attention while connecting the wire.

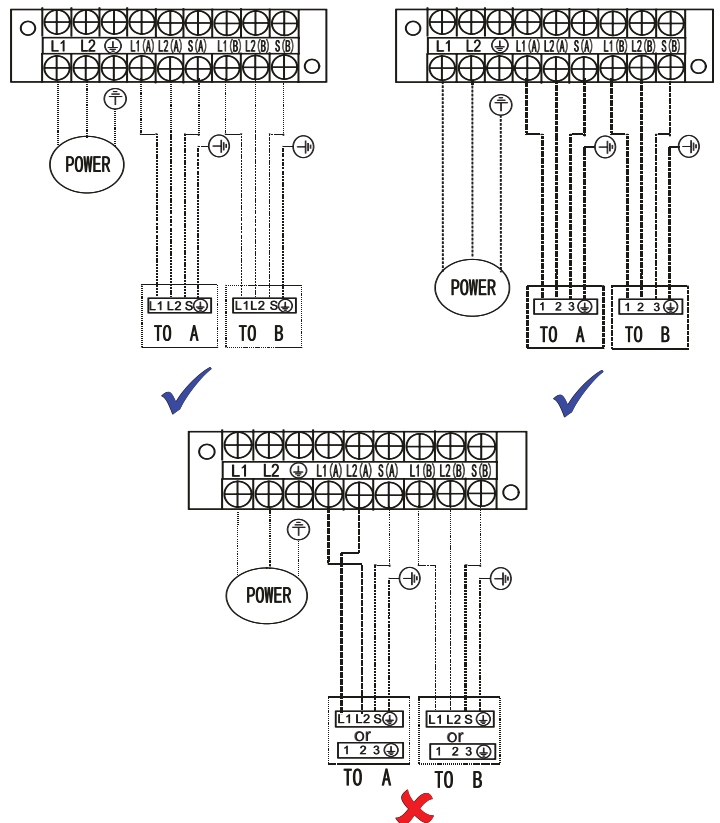

Fig. 5-3: High Voltage Power Connections

Power Wiring for Different Multi-Split Scenarios

NOTE

---- This symbol indicates field wiring.

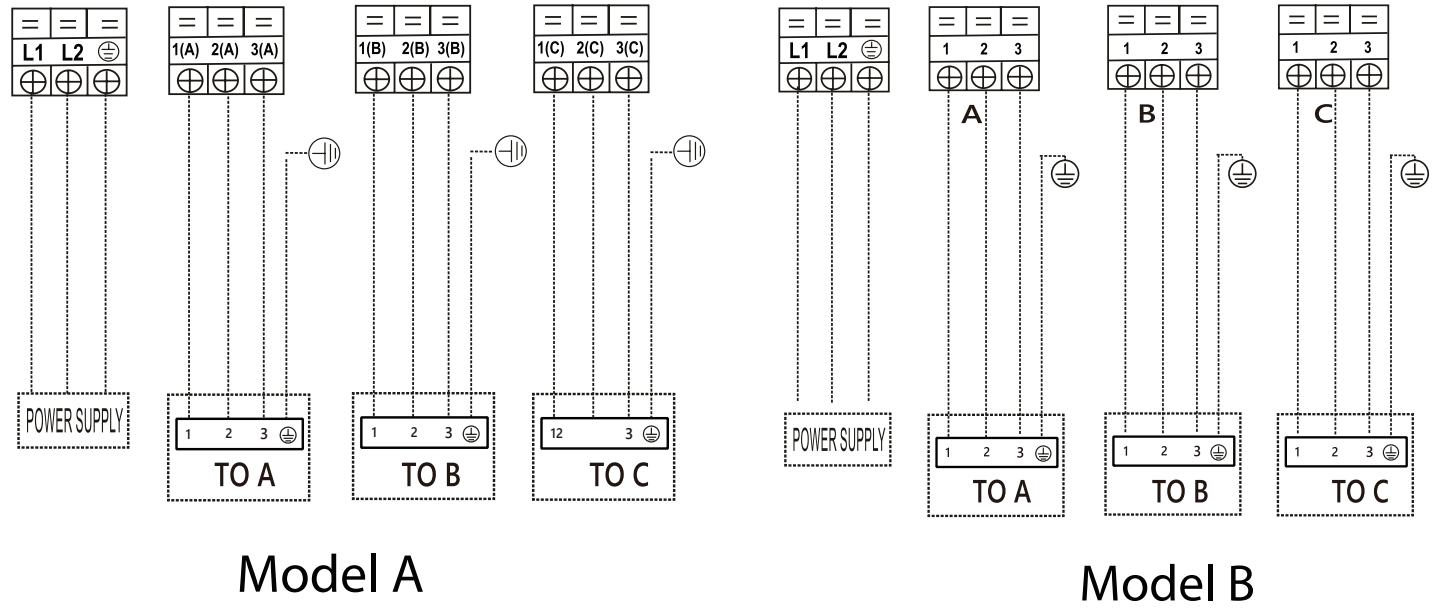

Fig. 5-4: One-Three Models

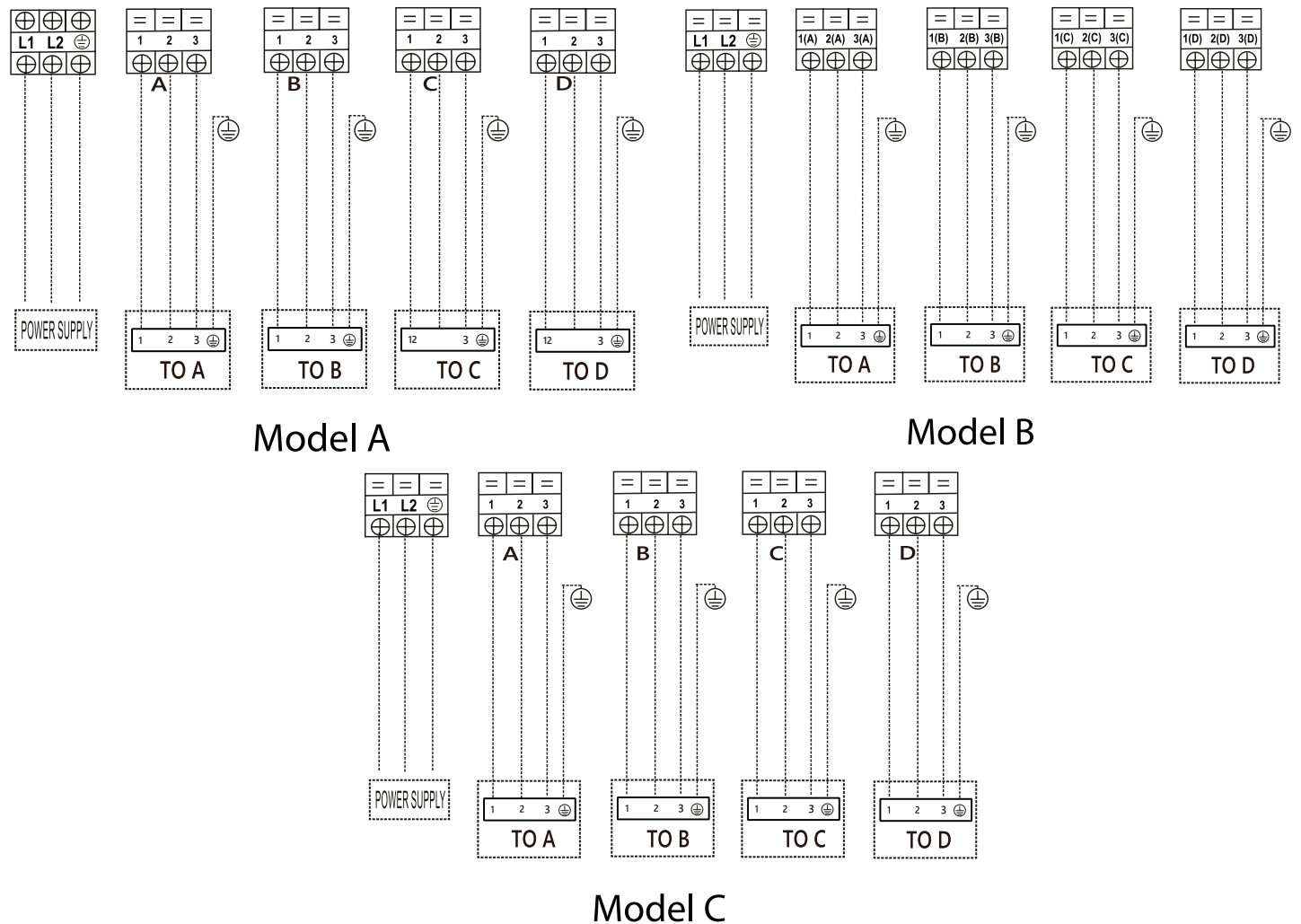

Fig. 5-5: One-Four Models

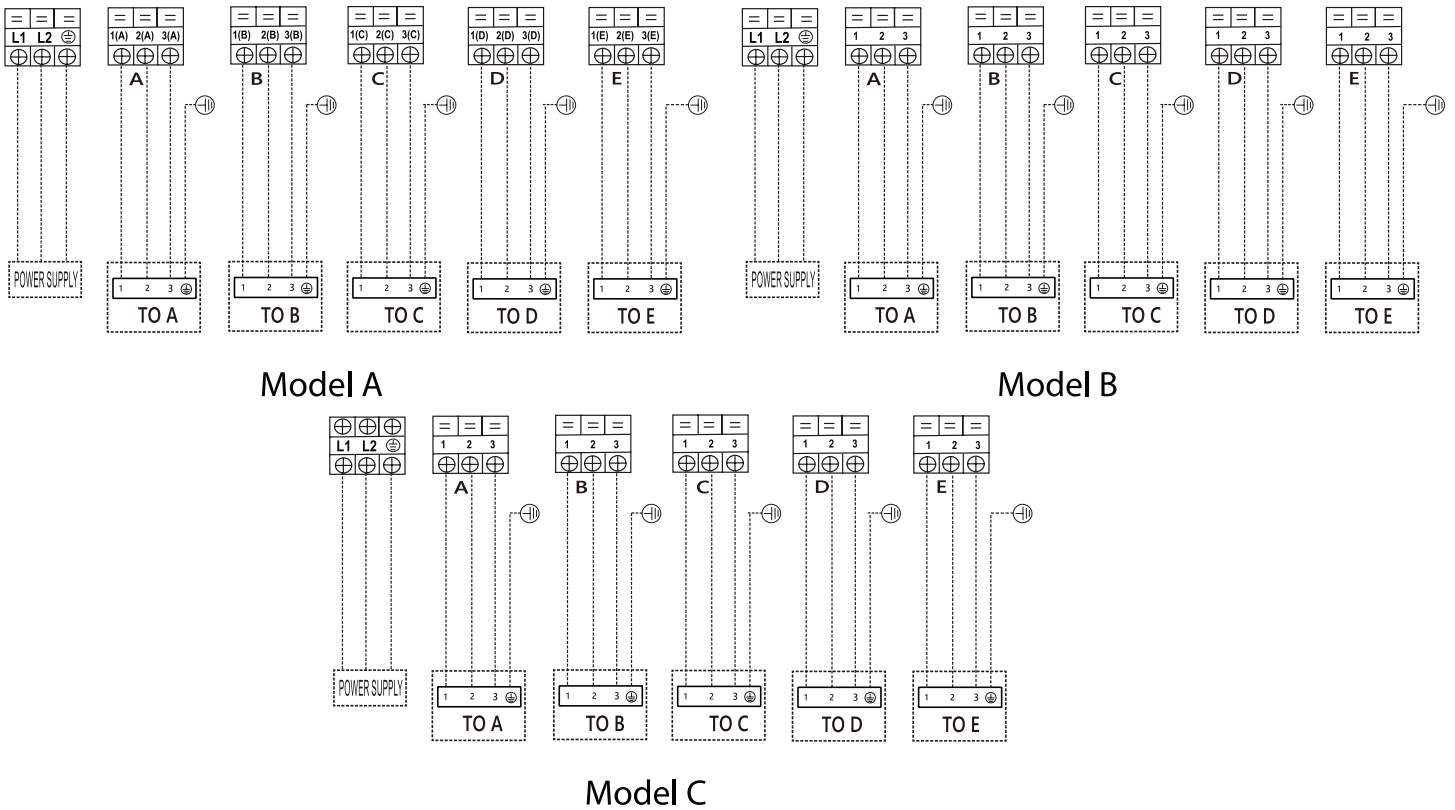

Fig. 5-6: One-Five Models

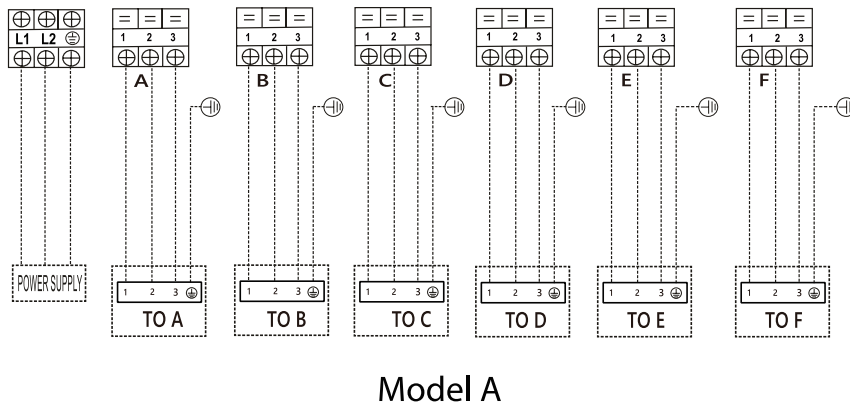

Fig. 5-7: One-Six Models

CAUTION

After confirmation of the above conditions, follow these guidelines when performing wiring:

- Always have an individual power circuit specifically for the air conditioner. Always follow the circuit diagram posted on the inside of the control cover.
- Screws fastening the wiring in the casing of electrical fittings may come loose during transportation. Because loose screws may cause wire burn-out, check that the screws are tightly fastened.
- Check the specifications for the power source.
- Confirm that electrical capacity is sufficient.
- Confirm that starting voltage is maintained at more than 90 percent of the rated voltage marked on the nameplate.

- Confirm that the cable thickness is as specified in the power source specifications.
- Always install an earth leakage circuit breaker in wet or moist areas.
- The following can be caused by a drop in voltage: vibration of a magnetic switch, damaging the contact point, broken fuses, and disturbance of normal functioning.
- Disconnection from a power supply must be incorporated into the fixed wiring. It must have an air gap contact separation of at least 3mm in each active (phase) conductor.
- Before accessing terminals, all supply circuits must be disconnected.

Step 6 - Air Evacuation

NOTE

When opening valve stems, turn the hexagonal wrench until it hits the stopper. Do not try to force the valve to open further.

Open valves slowly until you hear refrigerant, and allow pressure to equalize before opening fully. Open the large vapor line valve first.

PREPARATIONS AND PRECAUTIONS

Air and foreign matter in the refrigerant circuit can cause abnormal rises in pressure, which can damage the air conditioner, reduce its efficiency, and cause injury. Use a vacuum pump and manifold gauge to evacuate the refrigerant circuit, removing any non-condensable gas and moisture from the system. Evacuation should be performed upon initial installation and when the unit is relocated.

BEFORE PERFORMING EVACUATION

- Check to make sure the connective pipes between the indoor and outdoor units are connected properly.
- Check to make sure all wiring is connected properly.

Evacuation Instructions

1. Connect the charge hose of the manifold gauge to the service port on the outdoor unit's low pressure valve.
2. Connect another charge hose from the manifold gauge to the vacuum pump.
3. Open the Low-Pressure side of the manifold gauge. Keep the High-Pressure side closed.
4. Tighten refrigerant valve caps hand-tight plus flat to ensure there are no vacuum leaks.
5. Turn on the vacuum 5 to evacuate the system.

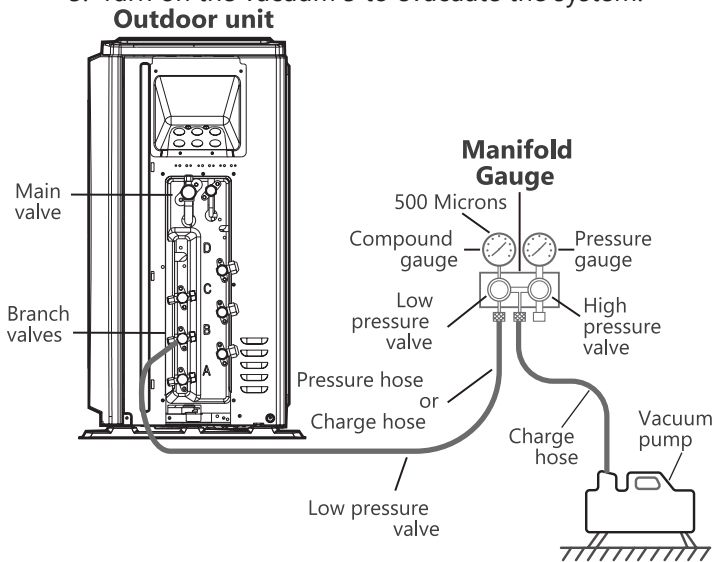

Fig. 6-1: Manifold Gauge Arrangement

6. Run the vacuum for at least 15 minutes, or until the Compound Meter reads 500 microns.
7. Close the Low-Pressure side of the manifold gauge and turn off the vacuum pump.
8. Wait for 5 minutes, then check that there has been no change in system pressure.
9. If there is a change in system pressure, refer to the Gas Leak Check section for information on how

to check for leaks. If there is no change in system pressure, unscrew the cap from the packed valve (high-pressure valve).

10. Insert a hexagonal wrench into the packed valve (high-pressure valve) and open the valve by turning the wrench in a 1/4 counterclockwise turn. Listen for gas to exit the system, then close the valve after 5 seconds.
11. Watch the Pressure Gauge for one minute to make sure that there is no change in pressure. The Pressure Gauge should read slightly higher than atmospheric pressure.
12. Remove the charge hose from the service port.

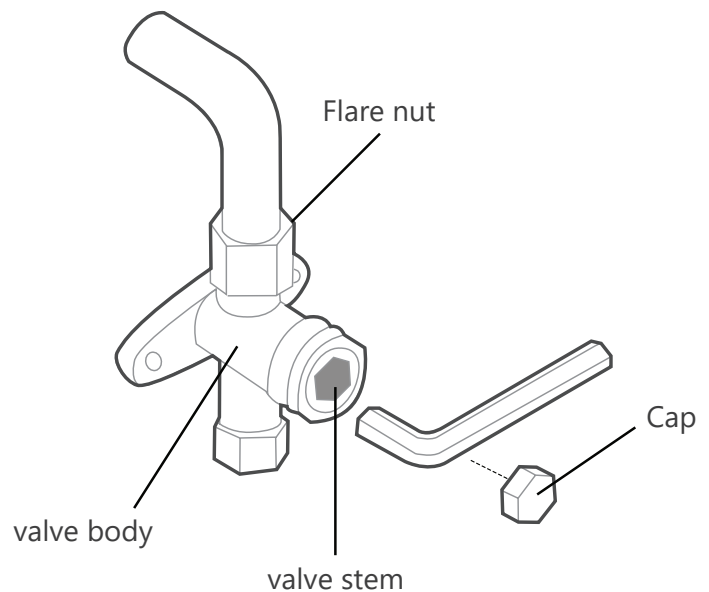

Fig. 6-2: Service Valve

13. Using a hexagonal wrench, fully open both the high-pressure and low-pressure valves.
14. Tighten all valve caps hand-tight plus one flat to ensure no leaks. You may tighten it further using a torque wrench if needed.

Safety And Leakage Check

Electrical safety check

Perform the electrical safety check after completing installation. Cover the following areas:

1. **Insulated resistance:** The insulated resistance must be more than 2MΩ.
2. **Grounding work:** After finishing the grounding work, measure the grounding resistance by visual detection and using the grounding resistance tester. Make sure the grounding resistance is less than 4Ω.
3. **Electrical leakage check (test while the unit is on):** During a test operation after completed installation, the use of an electro probe and multimeter to perform an electrical leakage check. Turn off the unit immediately if leakage happens. Try and evaluate different solutions until the unit operates properly.

Gas leak check

1. **Soap water method:** Apply a soap-water solution or a liquid-neutral detergent on the indoor unit connection

or outdoor unit connections with a soft brush to check for leakage of the connecting points of the piping. If bubbles emerge, the pipes are experiencing leakage.

2. **Leak detector:** Use the leak detector to check for leakage.

NOTE

The illustration is for example purposes only. The actual order of A, B, C, D, E, and F on the machine may be slightly different from the unit you purchased but the general shape will remain the same.

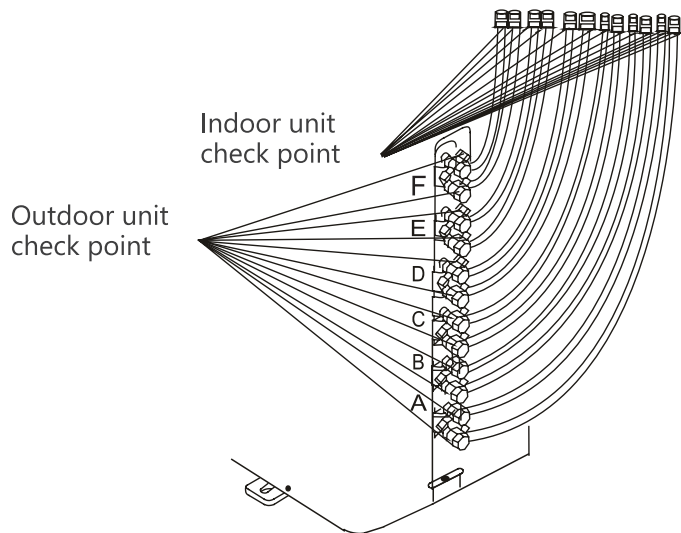

Fig. 6-3: Valve Check Points

A, B, C, and D are points for one of four types.
 A, B, C, D, and E are points for the one-five type.
 A, B, C, D, E, and F are points for the one-six type.

NOTE ON ADDING REFRIGERANT

- Refrigerant charging must be performed after wiring,

CAUTION

vacuuming, and the leak testing.

- **DO NOT** exceed the maximum allowable quantity of refrigerant or overcharge the system. Doing so can damage the unit or impact its functioning.
- Charging with unsuitable substances may cause explosions or accidents. Ensure that the appropriate refrigerant is used.
- Refrigerant containers must be opened slowly. Always use protective gear when charging the system.
- **DO NOT** mix refrigerant types.

Some systems require additional charging depending on pipe lengths. In North America, the standard pipe length is 25 ft. (7.5 m). The refrigerant should be charged from the service port on the outdoor unit's low-pressure valve. The additional refrigerant to be charged can be calculated using the following formula:

Table 6-1: Additional Refrigerant Formula

Refrigerant Type: R454B	Liquid Side Diameter	
	Ø 1/4 in. (Ø 6.35 mm)	≈3/8 in. (≈9.52 mm)
(orifice tube in the Indoor Unit):	(Total Pipe length - standard pipe length) x16 (0.15) [oz./ft. (g/m)]	(Total pipe length - standard pipe length) x32 (0.30) [oz./ft. (g/m)]

Start-Up

CAUTION

Failure to perform the test run may result in unit damage, property damage, or personal injury.

Before the Test Run

A test run must be performed after the entire system has been completely installed. Confirm the following points before performing the test:

- a. Indoor and outdoor units are properly installed.
- b. Piping and wiring are properly connected.
- c. No obstacles near the inlet and outlet of the unit that might cause poor performance or product malfunction.
- d. The refrigeration system does not leak.
- e. The drainage system is unimpeded and draining to a safe location.
- f. Heating insulation is properly installed.
- g. Grounding wires are properly connected.
- h. Length of the piping and additional refrigerant capacity have been recorded.
- i. Power voltage is the correct voltage for the air conditioner

Test run Instructions

1. Open both the liquid and gas service valves.
2. Turn on the main power switch and allow the unit to warm up.
3. Set the air conditioner to COOL mode.
4. For the Indoor Unit
 - a. Double-check to see if the room temperature is being registered correctly.
 - b. Check to see that the drainage system is unimpeded and draining smoothly.
 - c. Ensure there is no vibration or abnormal noise during operation.
5. For the Outdoor Unit
 - a. Check to see if the refrigeration system is leaking.
 - b. Make sure there is no vibration or abnormal noise during operation.
 - c. Ensure the wind, noise, and water generated by the unit do not disturb your neighbors or pose a safety hazard.
6. Drainage Test
 - a. Ensure the drainpipe flows smoothly. New buildings should perform this test before finishing the ceiling.
 - b. Turn on the main power switch and run the air conditioner in COOL mode.
 - c. Check to see that the water is discharged. It may take up to one minute before the unit begins to drain depending on the drainpipe.
 - d. Make sure that there are no leaks in any of the piping.
 - e. Stop the air conditioner. Turn off the main power switch and reinstall the test cover.

NOTE

If the unit malfunctions or does not operate according to your expectations, please refer to the Troubleshooting section of the Service Manual before calling customer service.

Automatic Wiring/Piping Correction

Automatic Wiring/Piping Correction Function

More recent models now feature automatic correction of wiring/piping errors. Press the "check switch" on the outdoor unit PCB board for 5 seconds until the LED displays "CE", indicating that this function is working, approximately 5-10 minutes after the switch is pressed, the "CE" disappears, meaning that the wiring/piping error is corrected, and all wiring/piping is properly connected.

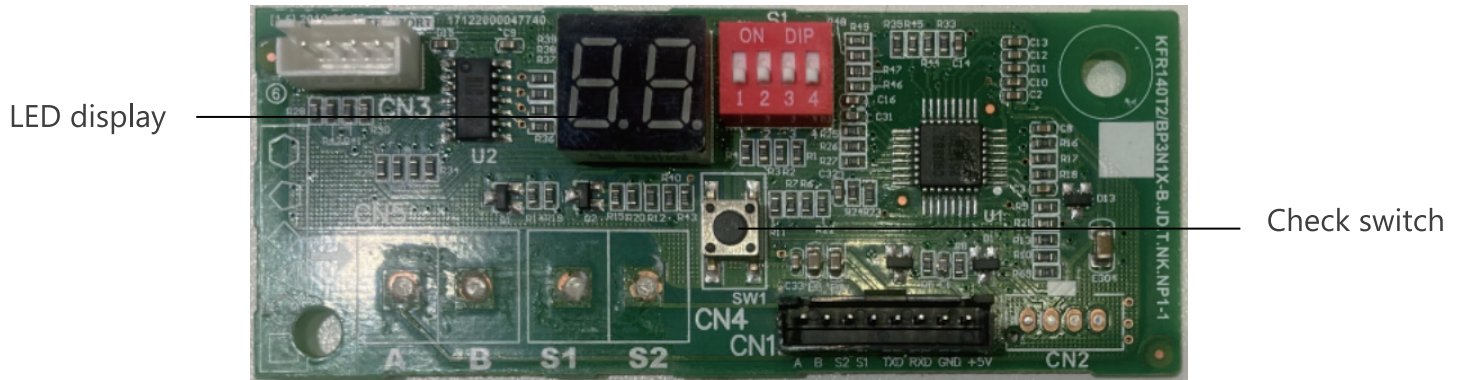

Correct

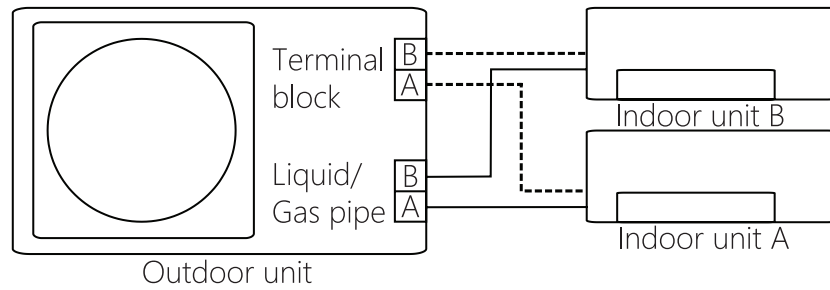

Incorrect wiring

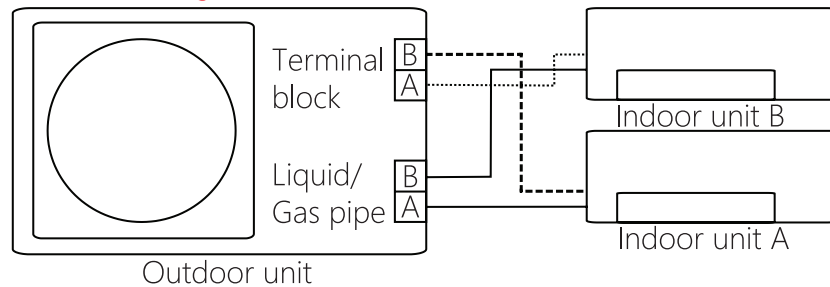

Incorrect wiring

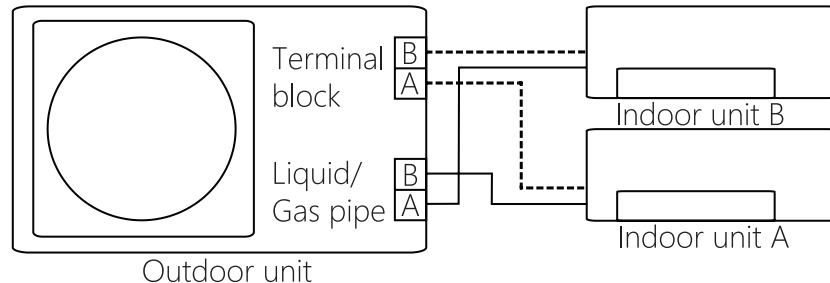

Fig. PW-1: Piping/Wiring Connections

How To Activate This Function

1. Check that the outside temperature is above 5°C. (This function does not work when the outside temperature is not above 41°F (5°C))
2. Check that the stop valves of the liquid pipe and gas pipe are open.
3. Turn on the breaker and wait at least 2 minutes.
4. Press the check switch on the outdoor PCB board unit LED display "CE".

Operation Instructions

Unit Features

Compressor protection

- The compressor cannot restart for 3 minutes after it stops.

Anti-cold air

- The unit is designed not to blow cold air on HEAT mode, when the indoor heat exchanger is in one of the following three situations and the set temperature has not been reached.
 - A. When heating has just started.
 - B. During defrosting.
 - C. Low-temperature heating.
- The indoor or outdoor fan stops running when defrosting (Cooling and heating models only).

Defrosting

- Frost may be generated on the outdoor unit during a heat cycle when outdoor temperature is low and humidity is high resulting in lower heating efficiency in the air conditioner.
- Under these conditions, the air conditioner will stop heating operations and start defrosting automatically.
- The time to defrost may vary from 4 to 10 minutes, depending on the outdoor temperature and the amount of frost buildup on the outdoor unit.

Auto-Restart

In case of power failure, the system will immediately stop. When power returns, the Operation light on the indoor unit will flash. To restart the unit, press the **ON/OFF** button on the remote control. If the system has an auto restart function, the unit will restart using the same settings.

The air conditioner turns to FAN ONLY mode from COOL or HEAT mode.

When the indoor temperature reaches the set temperature setting, the compressor will stop automatically, and the air conditioner turns to FAN-only mode. The compressor will start again when the indoor temperature rises on COOL mode or falls on HEAT mode to the set point.

Droplets of water may form on the surface of the indoor unit when cooling occurs in relatively high humidity (defined as higher than 80%). Adjust the horizontal louver to the maximum air outlet position and select HIGH fan speed.

White mist emerging from the indoor unit

- A white mist may be generated due to a large temperature difference between the air inlet and air outlet on the COOL mode in places with high relative humidity.
- A white mist may be generated due to moisture created in the defrosting process when the air conditioner restarts in HEAT mode operation after defrosting.

Noise coming from the air conditioner

- You may hear a low hissing sound when the compressor is running or has just stopped running. This sound is the sound of the refrigerant flowing or coming to a stop.
- You may also hear a low "squeaking" sound when the compressor is running or has just stopped running. This is caused by tempera heat expansion and cold contraction of the plastic parts in the unit when the temperature changes.
- A noise may be heard due to the louver restoring itself

to its original position when power is first turned on.

Dust blowing out from the indoor unit.

This happens when the air conditioner has not been used for a long time or during its first use.

Smell emitting from the indoor unit.

This is caused by the indoor unit giving off smells permeated from building materials, furniture, or smoke.

Heating mode

The air conditioner draws in heat from the outdoor unit and releases it via the indoor unit during heating. When the outdoor temperature falls, heat drawn in by the air conditioner decreases accordingly. At the same time, the heat loading of the air conditioner increases due to the larger difference between indoor and outdoor temperatures. If a comfortable temperature cannot be achieved with the air conditioner alone, it is recommended that you use a supplementary heating device.

Lightning or a wireless car telephone operating nearby may cause the unit to malfunction. Disconnect the unit from its power source and then re-connect the unit with the power source again. Push the ON/OFF button on the remote controller to restart operations.

Outdoor Unit Reverse Fan Operation function:

This feature helps keep the outdoor coil cleaner and may extend the duration between regular maintenance intervals depending on local conditions. When the unit is turned off, a 10-second delay occurs then the outdoor fan runs in reverse rotation for 70 seconds to blow off loose accumulated dust and debris.

Thermal-off in heat mode:

When one indoor temperature reaches its temperature setting in heat mode, but the compressor is still running, in order to prevent excessive heating, the FAN will run 1 minute ON and 8 minutes OFF in the cycle. The indoor temperature detection of this unit may be inaccurate because of thermal accumulation, causing difficulties in exiting thermal-off. It is recommended to activate the "follow me" function on the remote controller.

Energy Saving Tips

- **DO NOT** set the unit to excessive temperature levels.
- While cooling, close the curtains to avoid direct sunlight.
- Doors and windows should be kept closed to keep cool or warm air in the room.
- **DO NOT** place objects near the air inlet and outlet of the unit. This will reduce the efficiency of the unit.
- Set a timer and use the built-in SLEEP/ECONOMY mode if applicable.
- If you don't plan to use the unit for a long time, remove the batteries from the remote control.
- Clean the air filter every two weeks. A dirty filter can reduce cooling or heating efficiency.
- Adjust louvers properly and avoid direct airflow.

Manual Operations and Maintenance

Operation mode selection

While two or more indoor units are simultaneously operating, make sure the modes do not conflict with each other. The heat mode claims precedence over all other modes. If the unit initially started to operate in HEAT mode, the other units could operate in HEAT mode only. For example: If the unit initially started operating under COOL (or FAN) mode, the other units can operate under any mode except HEAT. If one of the units selects HEAT mode, the other operating units will stop operation and display "--" (for units with display window only) or the auto and operation indication light will flash rapidly, the defrost indication light will turn off, and the timer indication light will remain on (for units without a display window). Alternatively, the defrost and alarm indication light (if applicable) will light up, or the operation indication light will flash rapidly, and the timer indication light will turn off (for the floor and standing type).

Maintenance

If you plan to leave the unit idle for a long time, perform the following tasks:

1. Clean the indoor unit and air filter.
2. Select FAN ONLY mode and let the indoor fan run for a time to dry the inside of the unit.
3. Disconnect the power supply and remove the battery from the remote control.
4. Check the components of the outdoor unit periodically. Contact a local dealer or a customer service center if the unit requires servicing.

NOTE

Before you clean the air conditioner, be sure to switch off the unit and disconnect the power supply plug.

Optimal operation

- Adjust the direction of the airflow so that it is not blowing directly on people.
- Adjust the temperature to achieve the highest possible level of comfort. Do not adjust the unit to excessive temperature levels.
- Close the doors and windows in COOL mode or HEAT mode.
- Use the TIMER ON button on the remote control to select a time you want to start your air conditioner.
- Do not place any object near the air inlet or air outlet, as the efficiency of the air conditioner may be reduced, and the air conditioner may stop running.
- Clean the air filter periodically, otherwise cooling or heating performance may be reduced.
- Do not operate the unit with a horizontal louver in the closed position.

SUGGESTION

For units that feature an electric heater, when the outside ambient temperature is below 32°F (0°C), it is strongly recommended that you keep the machine plugged in to guarantee smooth operation.

When using the air conditioner after it has been idle:

- Use a dry cloth to wipe off the dust accumulated on the rear air intake grille to avoid the dust being dispersed from the indoor unit.
- Check that the wiring is not broken off or disconnected.
- Check that the air filter is installed.
- Check if the air outlet or inlet is blocked after the air conditioner has not been used for a long time.

Troubleshooting

⚠ CAUTION

If any of the following conditions occurs, turn off your unit immediately!

- The power cord is damaged or abnormally warm
- You smell a burning odor

- The unit emits loud or abnormal sounds
- A power fuse blows or the circuit breaker frequently trips
- Water or other objects fall into or out of the unit

DO NOT ATTEMPT TO FIX THESE YOURSELF! CONTACT AN AUTHORIZED SERVICE PROVIDER IMMEDIATELY.

Table T-1: Common Issues

The following problems are not malfunctions and, in most situations will not require repairs.

Issue	Possible Causes
The unit does not turn on when pressing the ON/OFF button	The Unit has a 3-minute protection feature that prevents the unit from overloading. The unit cannot be restarted within three minutes of being turned off.
	Cooling and Heating Models: If the Operation light and PRE-DEF (Pre-heating/ Defrost) indicators are lit up, the outdoor temperature is too cold, and the unit's anti-cold wind is activated to defrost the unit.
	In Cooling-only Models: If the Fan Only" indicator is lit up, the outdoor temperature is too cold, and the unit's anti-freeze protection is activated in order to defrost the unit.
The unit changes from COOL/HEAT mode to FAN mode	The unit may change its setting to prevent frost from forming on the unit. Once the temperature increases, the unit will start operating again in the previously selected mode.
	The set temperature has been reached, at which point the unit turns off the compressor. The unit will continue operating when the temperature fluctuates again.
The indoor unit emits a white mist	In humid regions, a large temperature difference between the room's air and the conditioned air can cause white mist.
Both the indoor and outdoor units emit white mist	When the unit restarts in HEAT mode after defrosting, a white mist may be emitted due to moisture generated from the defrosting process.
The indoor unit makes noises	A squeaking sound is heard when the system is OFF or in COOL mode. The noise is also heard when the drain pump (optional) is in operation.
	A squeaking sound may occur after running the unit in HEAT mode due to expansion and contraction of the unit's plastic parts.
Both the indoor unit and outdoor unit make noises	A low hissing sound may occur during operation. This is normal and is caused by refrigerant gas flowing through both the indoor and outdoor units.
	A low hissing sound may be heard when the system starts, has just stopped running or is defrosting. This noise is normal and is caused by the refrigerant gas stopping or changing direction.
The outdoor unit makes noises	The unit will make different sounds based on its current operating mode.
Dust is emitted from either the indoor or outdoor unit	The unit may accumulate dust during extended periods of non-use, which will be emitted when the unit is turned on. This can be mitigated by covering the unit during long periods of inactivity.
The unit emits a bad odor	The unit may absorb odors from the environment (such as furniture, cooking, cigarettes, etc.) which will be emitted during operations.
	The unit's filters have become moldy and should be cleaned.
The fan of the outdoor unit does not operate	During operation, the fan speed is controlled to optimize product operation.

NOTE

If a problem persists, contact a local dealer or your nearest customer service center. Provide them with a detailed description of the unit malfunction as well as your model number.

Table T-2: When To Call For Repairs

When troubles occur, please check the following points before contacting a repair company.

Problem	Possible Causes	Solution
Poor Cooling Performance	The temperature setting may be higher than the ambient room temperature	Lower the temperature setting
	The heat exchanger on the indoor or outdoor unit is dirty	Clean the affected heat exchanger
	The air filter is dirty	Remove the filter and clean it according to the instructions
	The air inlet or outlet of either unit is blocked	Turn the unit off, remove the obstruction, and turn it back on
	Doors and windows are open	Make sure that all doors and windows are closed while operating the unit
	Excessive heat is generated by sunlight	Close windows and curtains during periods of high heat or bright sunshine
	Low refrigerant due to leak or long-term use	Check for leaks, re-seal if necessary, and top off refrigerant
The unit is not working	Power failure	Wait for the power to be restored
	The power is turned off	Turn on the power
	The fuse is burned out	Replace the fuse
	Remote control batteries are dead	Replace batteries
	The Unit's 3-minute protection has been activated	Wait three minutes after restarting the unit
The unit starts and stops frequently	The system circuit is blocked	Determine which circuit is blocked and replace the malfunctioning piece of equipment
	There's too much or too little refrigerant in the system	Check for leaks and recharge the system with refrigerant.
	Incompressible gas or moisture has entered the system.	Evacuate and recharge the system with refrigerant
	There is air, incompressible gas, or foreign material in the refrigeration system.	Evacuate and recharge the system with refrigerant
	The compressor is broken	Replace the compressor
	The voltage is too high or too low	Install a manostat to regulate the voltage
Poor heating performance	The outdoor temperature is lower than 44.5°F (7°C)	Check for leaks and recharge the system with refrigerant
	Cold air is entering through doors and windows	Make sure that all doors and windows are closed during use
	Low refrigerant due to leak or long-term use	Check for leaks, re-seal if necessary, and top off refrigerant

This solution should be performed by a qualified technician.



Important!

Product Warranty Information

The Warranty Registration below is a requirement to print a warranty certificate. You're not mandated to register your products to enjoy the Midea Standard Warranty; however, registration is highly recommended. Registering your warranty within 60 days ensures easy access to support and service when needed.

The design and specifications may change without prior notice in order to enhance the product. For detailed information, please consult your sales agency or the manufacturer. Any updates to the manual will be posted on the service website, so be sure to check for the latest version.

United States



<https://www.mideacomfort.us/registration.html>

Canada

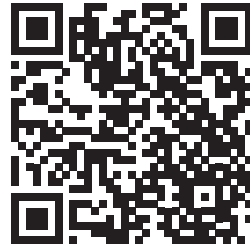

<https://www.mideacomfortna.ca/registration.html>