

R454b Refrigerant

SUBMITTAL DATA SHEET



Series Name: Multi Zone Regular Heat Series
Model Number: MO5EX-H36B-2A

Multi Zone Heat Pump System

Location:	Approval:
Engineer:	Date:
Submitted to:	Construction:
Submitted by:	Unit #:
Reference:	Drawing #:



OUTDOOR SPECIFICATION

Compressor Type	ROTARY	
Compressor Model	KTF310D43UMT	
Refrigerant	R454B	
Refrigerant Oil Charge(mL)	1000	
Refrigerant Oil	V74	
Outdoor Air Flow (Max) (CFM)	2148	
Outdoor Noise Level (dBA)	64.5	
Dimension (WxDxH)	inch	37-1/4 x 16-1/8 x 31-7/8
	mm	946 x 410 x 810
Package (WxDxH)	inch	42-7/8 x 19-5/8 x 34-7/8
	mm	1090 x 500 x 885
Net/Gross Weight	lbs	169 / 180
	kg	76.6 / 81.7

ELECTRICAL

Power Supply	208/230V,60Hz,1Ph
System MCA	30.5
Connection Wiring	AWG 14/4
System MOCP	35.0
Compressor RLA	17
Outdoor Fan Motor RLA	1.3
Outdoor Fan Motor W	120
Indoor Fan Motor RLA	/
Indoor Fan Motor W	/
System Power Input @ Cooling (W)	3,000 (600~4,100)
System Power Input @ Heating (W)	3,098 (600~3,900)
MCA: Min. circuit amps (A)	MOCP: Max. over current protection (A)
RLA: Rated load amps (A)	W: Fan motor rated output (W)

EFFICIENCY

Cooling		Heating	
SEER2	24.0	HSPF2-4	9.5
EER2	12	COP	3.5

PERFORMANCE of Cooling

Cooling (Btu/hr)	
Rated Capacity	36,000
Min/Max Capacity	9,000~42,000
Moisture Removal(L/h)	0.1
Standard Operating Range(°F/°C)	-13~122 (-25~50)
Rated Cooling Conditions:	Indoor: 80°F DB/67°F WB Outdoor: 95°F DB/75°F WB

PERFORMANCE of Heating

Heating (Btu/hr)	
1. @ 47°F Rated	37,000
1. @ 47°F Min/Max Capacity	10,000~42,500
2. @ 17°F Rated(H32)	26,600
3. @ 5°F Rated: Capacity / COP(H42)	26,000 / 2
3. @ 5°F Max: Capacity	26,000
Standard Operating Range(°F/°C)	-13~75 (-25~24)
1. Conditions:	Indoor: 70°F DB/60°F WB Outdoor: 47°F DB/43°F WB
2. Conditions:	Indoor: 70°F DB/60°F WB Outdoor: 17°F DB/15°F WB
3. Conditions:	Indoor: 70°F DB/60°F WB Outdoor: 5°F DB/5°F WB

PIPING

Liquid Size	5 x 1/4" (5 x 6.35 mm)
Gas Size	4 x 3/8" + 1 x 1/2" (4 x 9.52 + 1 x 12.7 mm)
Max. Piping Length for all rooms(ft/m)	262 (80)
Max. Piping Length for one IDU(ft/m)	115 (35)
ax. Height Difference of IDU and ODU(ft/m)	49 (15)
Refrigerant Pre-charged Amount(oz/kg)	121 (3.42)
Refrigerant Precharge Length(ft/m)	25 (7.5) x 5
Additional Charge of Refrigerant (Φ6.35 (1/4") liquid pipe) ((oz/ft)/(g/m))	0.16 (15)
Additional Charge of Refrigerant (Φ9.52 (3/8") liquid pipe) ((oz/ft)/(g/m))	0.32 (30)
Connection Method	Flared

Outdoor Unit Dimension

Unit: inch (mm)

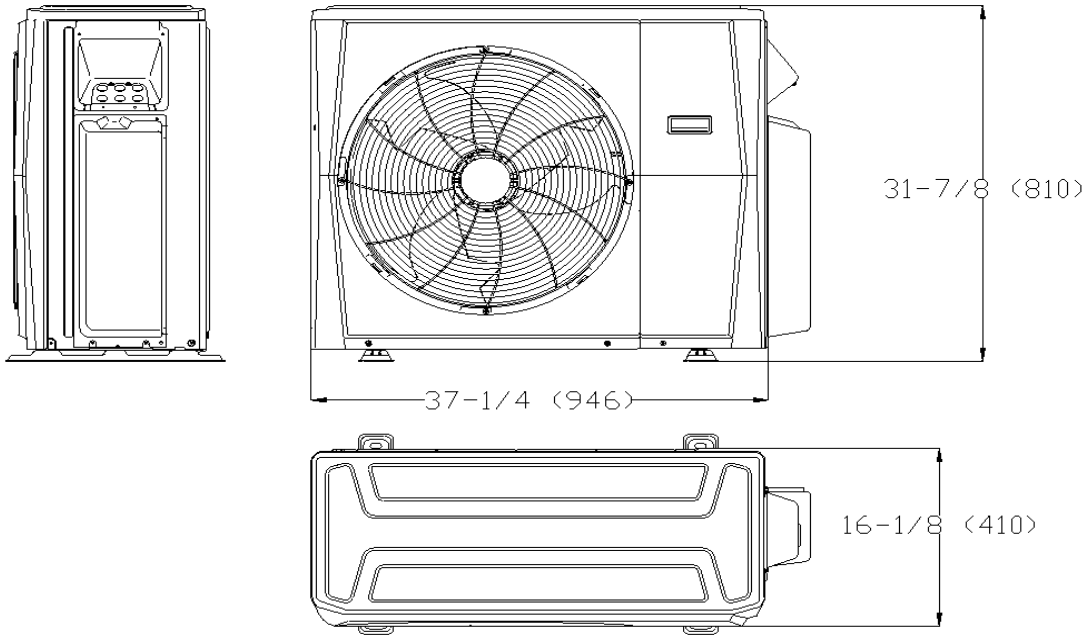

Installation Instruction

