



SUBMITTAL DATA SHEET

A-Coil Heat Pump System	
Location: _____ Engineer: _____ Submitted to: _____ Submitted by: _____ Reference: _____	Approval: _____ Date: _____ Construction: _____ Unit #: _____ Drawing #: _____

Set Code	22023110001108
Indoor unit code	22023111000510
Outdoor unit code	22023116000161
Set Model	
Indoor unit model	PAC-24B-HWDN1
Outdoor unit model	P30-24HFN1
Certified	AHRI  UL  



SYSTEM PERFORMANCE DATA		
Power supply		
Normal Operational Voltage	(V, Ph, Hz)	208/230V, 1Ph, 60Hz
Voltage Range	(V)	187-253
Electrical		
Minimum circuit ampacity(Outdoor)	(A)	20.0
Max.fuse(Outdoor)	(A)	35.0
Connection wiring		N/A
Cooling		
Capacity	(Btu/h)	24000(10000-28400)
Power Input	(W)	2247(380-2600)
Current	(A)	9.43(2.33-10.68)
SEER2	(Btu/W)	16.5
EER2	(Btu/W)	10.7
Heating		
Capacity	(Btu/h)	25000(9600-33400)
Power Input	(W)	2233(510-3160)
Current	(A)	9.30(3.01-12.92)
HSPF2-4	(Btu/W)	9.5
HSPF2-5	(Btu/W)	7.7
COP	W/W	3.28
Heat at 17F(H32)	(Btu/h)	21000
Heat at 5F(H42)	(Btu/h)	20000
COP at 5F(H42)	W/W	1.95

INDOOR UNIT DATA		
IRV	inch*3	58.30
Air flow	SCFM	550
Pressure drop	Pa	32.70
	In. wg.	0.13
Air flow & Noise level		
Indoor air flow (Hi/Med/Lo) (No duct)	(CFM)	/ / 705.88 / /
Indoor noise level (Hi/Med/Lo)	[dB(A)]	0/0/0
Dehumidification	(L/H)	2.8
Indoor unit		
Dimension (WxDxH)	(inch)	17.52x20.98x17.99
	(mm)	445x533x457
Packing(WxDxH)	(inch)	20.47x26.18x20.28
	(mm)	520x665x515
Net/Gross weight	(lbs.)	42.77/52.03
	(kg)	19.4/23.6

REFRIGERANT PIPE DATA		
Throttle type	Indoor unit	TXV
Design pressure	Outdoor unit	EEV for heating
Refrigerant Type	(PSIG)	550/340
Refrigerant charge		R410A
Refrigerant precharge	oz	102.32
Additional charge for each ft	(ft)	25.0
Additional charge for each m	(m)	7.5
Liquid side/ Gas side(indoor)	(oz/ft)	0.69
	(g/m)	65.0
Liquid side/ Gas side(outdoor)	(inch)	3/8" / 3/4"
	(mm)	9.52/19
	(inch)	3/8" / 3/4"
	(mm)	9.52/19
Max. pipe length	(ft)	164.0
	(m)	50.0
Max. difference in level	(ft)	82.0
	(m)	25.0
Connection method		Flared
Indoor(cooling)	(Deg. °F)	60 ~ 90
	(Deg. °C)	16 ~ 32
Indoor(heating)	(Deg. °F)	32 ~ 86
	(Deg. °C)	0 ~ 30
Outdoor(cooling)	(Deg. °F)	5-122
	(Deg. °C)	-15 ~ 50
Outdoor(heating)	(Deg. °F)	-22 ~ 75
	(Deg. °C)	-30 ~ 24

OUTDOOR UNIT DATA		
Compressor		
Type		Twin-ROTARY
Model		KTM240D57UMT
Brand		GMCC
Capacity	(Btu/h)	26409
Input	(W)	2085
Rated current (RLA)	(A)	15
Refrigerant oil/oil charge	(ml)	ESTER OIL VG74 670
Outdoor fan motor		
Model		ZKFN-120-8-2
Qty		1
Input	(W)	150.0
Output	(W)	120
RLA	(A)	1.4
Speed	(r/min)	950/700/500/400
Air flow & Noise level		
Outdoor air flow (Max.)	(CFM)	3000
Outdoor noise level	[dB(A)]	63.5
Outdoor unit		
Dimension (WxDxH)	(inch)	37.24x16.14x31.89
	(mm)	946x410x810
Packing (WxDxH)	(inch)	42.91x19.69x34.84
	(mm)	1090x500x885
Net/ Gross weight	(lbs.)	136.69/145.50
	(kg)	62/66

Indoor unit dimension

NEW PANEL STYLE

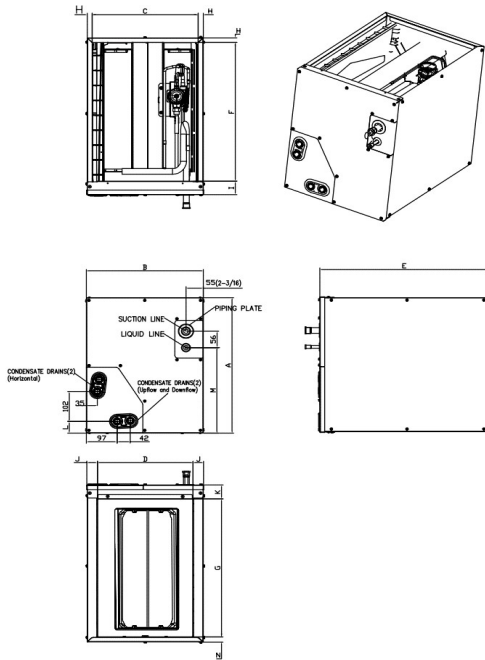

OLD PANEL STYLE

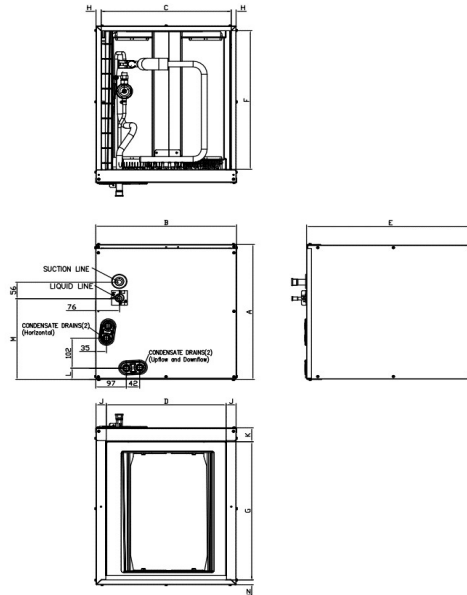

Dimensions	KV-14F-A		KV-14F-B		KV-17F-A		KV-17F-B		KV-21F-A		KV-21F-B		KV-24F-A	
	NEW PANEL STYLE 18K/20K/22K/24K		NEW PANEL STYLE 30K(未定)		NEW PANEL STYLE 30K/36K		OLD PANEL STYLE 18K/24K		OLD PANEL STYLE 30K/36K/48K		NEW PANEL STYLE 48K		OLD PANEL STYLE 60K	
	inch	mm	inch	mm	inch	mm	inch	mm	inch	mm	inch	mm	inch	mm
A Model Height	18	457	23-1/2	598	23-1/2	599	18	461	24	609	28	711	28	711
B Model Width	14-1/2	368	14-1/2	368	17-1/2	445	17-1/2	445	21	533	21	533	24-1/2	622
C Supply Air Opening Width	13-1/4	336	13-1/4	336	16-3/16	411	16-3/16	411	19-3/4	502	19-3/4	502	23-1/4	591
D Return Air Opening Width	12	303	12	303	15-1/8	384	15-1/8	384	19-1/2	496	19-1/2	496	23	585
E Model Depth	21	534	21	534	21	533	21	533	21	533	21	533	21	533
F Supply Air Opening Depth	18-5/8	473	18-5/8	473	18-5/8	473	18-5/8	473	18-5/8	473	18-5/8	473	18-5/8	473
G Return Air Opening Depth	18-1/2	471	18-1/2	471	18	458	18	458	18-1/2	470	18-1/2	470	18-1/2	470
H Supply Air Opening Side Clearance	5/8	16	5/8	16	5/8	16	5/8	16	5/8	16	5/8	16	5/8	16
I Supply Air Opening Front Clearance	1-3/4	45	1-3/4	45	1-3/4	45	1-3/4	45	1-3/4	45	1-3/4	45	1-3/4	45
J Return Air Opening Side Clearance	5/8	16	5/8	16	1-3/16	30	1-3/16	30	3/4	19	3/4	19	3/4	19
K Return Air Opening Front Clearance	1-13/16	46	1-13/16	46	1-13/16	46	1-13/16	46	1-13/16	46	1-13/16	46	1-13/16	46
L Condensate Drains Height	1-9/16	40	1-9/16	40	1-7/16	37	1-7/16	37	2-1/8	54	2-1/8	54	2-1/8	54
M Liquid Line Height	11-1/2	292	11-1/2	292	16-1/2	418	10-7/8	276	16-5/16	414	21	533	20-1/4	514
N Return Air Opening Side Clearance	3/4	19	3/4	19	3/4	19	1-3/16	30	3/4	19	3/4	19	3/4	19

Outdoor unit dimension

