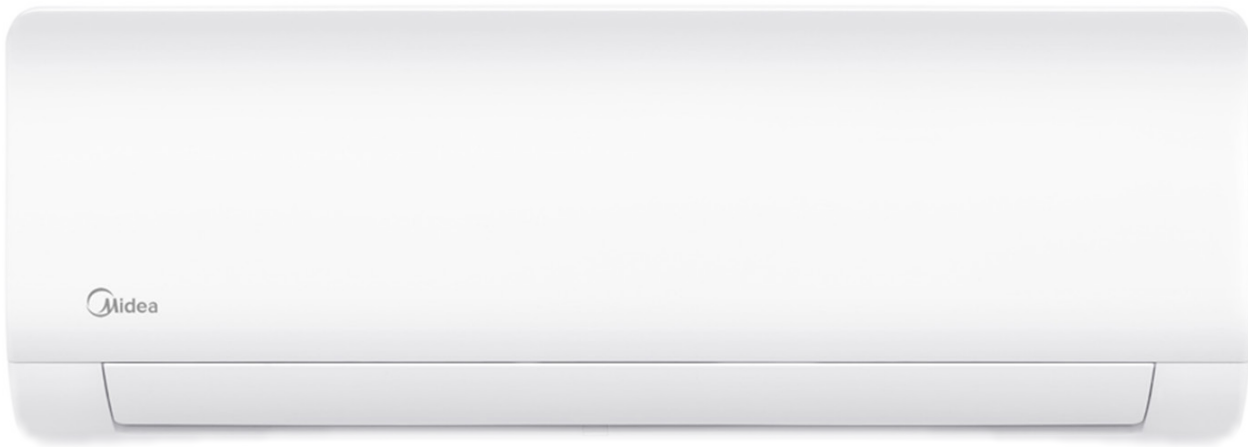


# Midea User/Installation Manual

## Infinite Wall Mounted Split Room Air Conditioner

For 9,000 - 36,000 BTU Systems



### NOTE

Please read this manual carefully before operating your new air conditioning unit and save it for future reference.



### Units Covered In This Manual

BTUH	VOLTAGE/ PHASE	HIGH WALL SPLIT
9,000	115-1	MSGNS-H09B-1A
12,000	115-1	MSGNS-H12B-1A
9,000	208/230-1	MSGNS-H09B-2A
12,000	208/230-1	MSGNS-H12B-2A
18,000	208/230-1	MSGNS-H18B-2A
24,000	208/230-1	MSGNS-H24B-2A
30,000	208/230-1	MSGNS-H30B-2A
36,000	208/230-1	MSGNS-H36B-2A



Manufacturer reserves the right to change, at any time, specifications and designs without notice and without obligations.

# User Manual

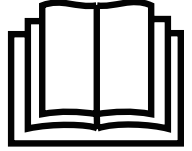
## Thank You

Thank you for choosing Midea! Before using your new Midea product, please read this manual thoroughly to ensure that you know how to operate the features and functions that your new appliance offers safely.

## Warning Notices:

Before using this product, please carefully read this manual and SAFETY MANUAL (if any) and keep it for future reference. The design and specifications are subject to change without prior notice for product improvement. Consult with your dealer or manufacturer for details.

The diagrams are just for reference. Please consider the appearance of the actual product to be standard.



### Caution:

Risk of fire/flammable materials



# A2L

## Table of Contents

<b>Safety Precautions</b> .....	<b>3</b>
Table S-1: Minimum Room Area Requirements .....	5
Table S-2: Minimum Airflow .....	5
Table S-3: Explanation of symbols displayed on the indoor unit or outdoor unit .....	9
<b>Specification</b> .....	<b>10</b>
<b>Get to Know Your AC</b> .....	<b>11</b>
Indoor Unit Display .....	11
More Features .....	12
Setting Airflow Angle .....	12
Manual Operation .....	13
Care & Maintenance .....	13
Troubleshooting .....	15
Common Issues .....	15
When To Call For Repairs .....	16

# Safety Precautions

It is crucial to read the Safety Precautions Before Operation and Installation. Neglecting these instructions may lead to serious damage or injury. The severity of potential damage or injuries is categorized as either a WARNING or CAUTION.

## WARNING

Hazards or unsafe practices that may result in severe personal injury or death.

## CAUTION

Hazards or unsafe practices may result in minor personal injury or property damage. Carefully follow the precautions because they are essential to guarantee the safety of the equipment.

### NOTE

A property-damage-only hazard, meaning no personal injury is possible.

### IMPORTANT

Is used to highlight suggestions which will result in enhanced installation, reliability, or operation.

## WARNING

State of California Proposition 65 Warning (US Only)  
This product contains chemicals known to the State of California to cause cancer, birth defects, or other reproductive harm.

## WARNING

Improper installation, adjustment, alteration, service, maintenance, or use can cause an explosion, fire, electrical shock, or other conditions that may cause death, personal injury, or property damage. Consult a qualified installer, service agency, distributor, or branch for information or assistance. The qualified installer or agency must use factory-authorized kits or accessories when modifying this product. Refer to the individual instructions packaged with kits or accessories when installing.

### IMPORTANT

Follow all safety codes. Wear safety glasses, protective clothing, and work gloves. Have a fire extinguisher available. Read these instructions thoroughly and follow all warnings or cautions in the literature and labels attached to the unit. Consult local building codes and the current editions of the National Electrical Code (NEC) NFPA 70.

### IMPORTANT

In Canada, refer to the current editions of the Canadian Electrical Code CSA C22.1. Follow the safety information.

## WARNING

This appliance is not intended for use by persons (including children) with reduced physical, sensory, or mental capabilities, or lack of experience and knowledge, unless Infinite Owner/Installation Manual

they have been given supervision or instruction concerning use of the appliance by a person responsible for their safety. Children should be supervised to ensure that they do not play with the appliance.

## WARNING

### FOR PRODUCT USE

- Turn off the air conditioner and disconnect the power before performing any cleaning. Failure to do so can cause electric shock.
- If an abnormal situation arises (like a burning smell), immediately turn off the unit and disconnect the power. Call your dealer for instructions to avoid electric shock, fire, or injury.
- **Do not** insert fingers, rods, or other objects into the air inlet or outlet. This may cause injury, since the fan may be rotating at high speeds.
- **Do not** use flammable sprays such as hair spray, lacquer, or paint near the unit. This may cause fire or combustion.
- **Do not** operate the air conditioner in places near or around combustible gases. Emitted gas may collect around the unit and cause an explosion.
- **Do not** operate your air conditioner in a wet room such as a bathroom or laundry room. Too much exposure to water can cause electrical components to short circuit.
- **Do not** expose your body directly to cool air for a prolonged time.
- **Do not** allow children to play with the air conditioner. Children must be always supervised around the unit.
- If the air conditioner is used together with burners or other heating devices, thoroughly ventilate the room to avoid oxygen deficiency.
- In certain functional environments, such as kitchens, server rooms, etc., the use of specially designed air-conditioning units is highly recommended.

## WARNING

### ELECTRICAL WARNINGS

- Only use the specified wire. If the wire is damaged, it must be replaced by the manufacturer, service agent, or similarly qualified persons to avoid a hazard.
- The product must be properly grounded at the time of installation, or electric shock may occur.
- For all electrical work, follow all local and national wiring standards, regulations, and the Installation Manual. Connect cables tightly and clamp them securely to prevent external forces from damaging the terminal. Improper electrical connections can overheat, cause fire, and may also cause shock. All electrical connections must be made according to the Electrical Connection Diagram located on the panels of the indoor and outdoor units.
- All wiring must be properly arranged to ensure that the control board cover can close properly. If the control board cover is not closed properly, it can lead to corrosion and cause the connection points on the terminal to heat up, catch fire, or cause electrical shock.



- Disconnection must be incorporated in the fixed wiring in accordance with the NEC, CEC, or local codes.
- **DO NOT** share the electrical outlet with other appliances. The unit must be installed on a dedicated electrical circuit.
- If connecting power to fixed wiring, an all-pole disconnection device that has at least 1/8 in. (3 mm) clearances in all poles, and has a leakage current that may exceed 10 mA, the residual current device (RCD) having a rated residual operating current not exceeding 30mA, and disconnection must be incorporated in the fixed wiring following the wiring rules.

## **WARNING**

### FOR PRODUCT INSTALLATION

- Turn off the air conditioner and disconnect the power before performing any installation or repair. Failure to do so can cause electric shock.
- Installation must be performed by an authorized dealer or specialist. Defective installation can cause water leakage, electrical shock, or fire.
- Installation must be performed according to the installation instructions. Improper installation can cause water leakage, electrical shock, or fire. Contact an authorized service technician for repair or maintenance of this unit.
- This appliance shall be installed following national wiring regulations. Only use the included accessories, parts, and specified parts for installation.
- Using non-standard parts can cause water leakage, electrical shock, and fire, and can cause the unit to fail.
- Install the unit in a firm location that can support the unit's weight. If the chosen location cannot support the unit's weight, or the installation is not done properly, the unit may drop and cause serious injury and damage.
- Install drainage piping according to the instructions in this manual. Improper drainage may cause water damage to your home and property.
- For units that have an auxiliary electric heater, do not install the unit within 1 meter (3 feet) of any combustible materials.
- For the units that have a wireless network function, USB device access, replacement, and maintenance operations must be carried out by professional staff.
- **Do not** install the unit in a location that may be exposed to combustible gas leaks. If combustible gas accumulates around the unit, it may cause fire.
- **Do not** turn on the power until all work has been completed.
- When moving or relocating the air conditioner, consult experienced service technicians for disconnection and reinstallation of the unit.
- How to install the appliance to its support, please read the information for details in "indoor unit installation" and "outdoor unit installation" sections.



## **WARNING**

### TAKE NOTE OF FUSE SPECIFICATIONS

The air conditioner's circuit board (PCB) is designed with a fuse to provide overcurrent protection. The specifications of the fuse are printed on the circuit board, for example: T3.15AL/250 VAC, T5AL/250 VAC, T3.15A/250 VAC, T5A/250 VAC, T20A/250 VAC, T30A/250 VAC, etc.

### NOTE

Only the blast-proof ceramic fuse can be used.

## **WARNING**

### WARNINGS FOR CLEANING AND MAINTENANCE

- Turn off the device and disconnect the power before cleaning. Failure to do so can cause electrical shock.
- **Do not** clean the air conditioner with excessive amounts of water.
- **Do not** clean the air conditioner with combustible cleaning agents. Combustible cleaning agents can cause fire or deformation.

## **CAUTION**

- Turn off the air conditioner and disconnect the power if you are not going to use it for a long time.
- Turn off and unplug the unit during storms.
- Make sure that water condensation can drain unhindered from the unit.
- **Do not** operate the air conditioner with wet hands. This may cause electric shock.
- **Do not** use the device for any other purpose than its intended use.
- **Do not** climb onto or place objects on top of the outdoor unit.
- **Do not** allow the air conditioner to operate for long periods with doors or windows open, or if the humidity is very high.

## **WARNING**

### USING FLAMMABLE REFRIGERANT

- **Do not** use means to accelerate the defrosting process or to clean, other than those recommended by the manufacturer.
- The appliance shall be stored in a room without continuously operating ignition sources (for example: open flames, an operating gas appliance, or an operating electric heater).
- **Do not** pierce or burn.
- Be aware that refrigerants may not contain an odor.
- **LEAK DETECTION SYSTEM** installed. The unit must be powered except for service. When the refrigerant sensor detects refrigerant leakage, the indoor unit will display an error code and emit a buzzing sound, the compressor of the outdoor unit will immediately stop, and the indoor fan will start running. The service life of the refrigerant sensor is 15 years. When the refrigerant sensor malfunctions, the indoor unit will display the error code "FHCC". The refrigerant sensor cannot be repaired and can only be replaced by the manufacturer. It shall only be replaced with the sensor

specified by the manufacturer. (Applicable to the units with refrigerant sensors only).

**For R454B refrigerant charge amount and minimum room area:**

The machine you purchased may be one of the types in the table below. The indoor and outdoor units are designed to be used together. Please check the machine you purchased. The indoor unit should be installed at least 6 ft. /1.8 m above the floor, the height of the room cannot be less than 7-1/3 ft. /2.2 m, and the minimum room area of operating or storage should be as specified in the following table.

**Table S-1: Minimum Room Area Requirements**

T <sub>Amin</sub> [ft. <sup>2</sup> /m <sup>2</sup> ]	h <sub>inst</sub> [ft/m]					
	6.0~7.3/ 1.8~2.2	7.6/2.3	7.9/2.4	8.6/2.6	9.2/2.8	9.9/3.0
<=62.6/1.776	12/1.10					
63.4/1.8	60/5.53	57/5.29	55/5.07	51/4.68	47/4.35	44/4.06
70.5/2.0	67/6.15	64/5.88	61/5.64	56/5.2	52/4.83	49/4.51
77.5/2.2	73/6.76	70/6.47	67/6.2	62/5.72	58/5.31	54/4.96
84.6/2.4	80/7.38	76/7.06	73/6.76	68/6.24	63/5.8	59/5.41
91.7/2.6	86/7.99	83/7.64	79/7.32	73/6.76	68/6.28	64/5.86
98.7/2.8	93/8.6	89/8.23	85/7.89	79/7.28	73/6.76	68/6.31
105.8/3.0	100/9.22	95/8.82	91/8.45	84/7.8	78/7.24	73/6.76
112.8/3.2	106/9.83	102/9.41	97/9.01	90/8.32	84/7.73	78/7.21
119.9/3.4	113/10.45	108/9.99	104/9.58	96/8.84	89/8.21	83/7.66
126.9/3.6	120/11.06	114/10.58	110/10.14	101/9.36	94/8.69	88/8.11
134/3.8	126/11.68	121/11.17	116/10.7	107/9.88	99/9.17	93/8.56
141.1/4.0	133/12.29	127/11.76	122/11.27	112/10.4	104/9.66	97/9.01
148.1/4.2	139/12.9	133/12.34	128/11.83	118/10.92	110/10.14	102/9.46
155.1/4.4	146/13.52	140/12.93	134/12.39	124/11.44	115/10.62	107/9.91
162.2/4.6	153/14.13	146/13.52	140/12.96	129/11.96	120/11.11	112/10.37
169.2/4.8	159/14.75	152/14.11	146/13.52	135/12.48	125/11.59	117/10.82
176.3/5.0	166/15.36	159/14.69	152/14.08	140/13	130/12.07	122/11.27
Area formula	<p><b>T<sub>Amin</sub></b> is the required minimum area of the total conditioned space connected by air ducts in ft.<sup>2</sup>/m<sup>2</sup></p> <p><b>Mc</b> is the actual refrigerant charge in the system in oz./kg</p> <p><b>MREL</b> is the refrigerant releasable charge in oz./kg</p> <p><b>h<sub>inst</sub></b> is the height of the bottom of the appliance relative to the floor of the room after installation.</p> <p><b>WARNING:</b> The minimum room area or minimum room area of conditioned space is based on releasable charge and total system refrigerant charge.</p>					

For the units with refrigerant sensors, when the unit detects a refrigerant leak, the minimum airflow of the indoor unit is as follows:

**Table S-2: Minimum Airflow**

Model	Indoor unit	Outdoor unit	Indoor nominal air volume	
09K(115V)	MSGNS-H09B-1A	MO1BS-H09B-1A	400m <sup>3</sup> /h	235 CFM
12K(115V)	MSGNS-H12B-1A	MO1BS-H12B-1A	500m <sup>3</sup> /h	295 CFM
09K	MSGNS-H09B-2A	MO1BS-H09B-2A	420m <sup>3</sup> /h	245 CFM
12K	MSGNS-H12B-2A	MO1BS-H12B-2A	500 <sup>3</sup> m/h	295 CFM
18K	MSGNS-H18B-2A	MO1BS-H18B-2A	680 <sup>3</sup> m/h	400 CFM
24K	MSGNS-H24B-2A	MO1BS-H24B-2A	930m <sup>3</sup> /h	545 CFM
30K	MSGNS-H30B-2A	MO1BS-H30B-2A	1,100m <sup>3</sup> /h	645 CFM
36K	MSGNS-H36B-2A	MO1BS-H36B-2A	1,110m <sup>3</sup> /h	655 CFM

The information in the following table is only applicable to models without refrigerant sensors:

Model	Indoor unit	Outdoor unit
09K(115V)	MSGNS-H09B-1A	MO1BS-H09B-1A
12K(115V)	MSGNS-H12B-1A	MO1BS-H12B-1A
09K	MSGNS-H09B-2A	MO1BS-H09B-2A
12K	MSGNS-H12B-2A	MO1BS-H12B-2A
18K	MSGNS-H18B-2A	MO1BS-H18B-2A
24K	MSGNS-H24B-2A	MO1BS-H24B-2A
30K	MSGNS-H30B-2A	MO1BS-H30B-2A
36K	MSGNS-H36B-2A	MO1BS-H36B-2A

**1. Installation** (where refrigerant pipes are allowed)

- Any person who is involved with working on or breaking into a refrigerant circuit should hold a current valid certificate from an industry-accredited assessment authority, which authorizes their competence to handle refrigerants safely in accordance with an industry-recognized assessment specification.
- Maintenance and repair requiring the assistance of other skilled personnel shall be carried out under the supervision of the person competent in the use of flammable refrigerants.
- That the installation of pipe work shall be kept to a minimum.
- That pipe work shall be protected from physical damage.
- Where refrigerant pipes shall comply with national gas regulations.
- That mechanical connections shall be accessible for maintenance purposes.
- Be more careful that foreign matter (oil, water, etc.) does not enter the piping. Also, when storing the piping, securely seal the opening by pinching, taping, etc.
- Appliance shall be stored in a well-ventilated area where the room size corresponds to the room area as specified for operation.
- Joints shall be tested with detection equipment with a capability of 5 g/year of refrigerant or better, with the equipment in a standstill and under operation or under pressure of at least these standstill or operation conditions after installation. Detachable joints should NOT be used on the indoor side of the unit (brazed, welded joints could be used).
- In cases that require mechanical ventilation, ventilation openings shall be kept clear of obstruction.

**2. When a FLAMMABLE REFRIGERANT is used,** the requirements for installation space of appliance and/or ventilation requirements are determined according to

- the mass charge amount (M) used in the appliance,
- the installation location,
- the type of ventilation of the location or the appliance.
- piping material, pipe routing, and installation shall include protection from physical damage in operation and service, and comply with national and local codes and standards, such as ASHRAE 15, IAPMO Uniform Mechanical Code, ICC International Mechanical Code, or CSA B52. All field joints shall be accessible for inspection before being covered or enclosed.
- that protection devices, piping, and fittings shall be

protected as far as possible against adverse environmental effects, for example, the danger of water collecting and freezing in relief pipes or the accumulation of dirt and debris;

- that piping in refrigeration systems shall be so designed and installed to minimize the likelihood of hydraulic shock damaging the system;
- that steel pipes and components shall be protected against corrosion with a rustproof coating before applying any insulation;
- that precautions shall be taken to avoid excessive vibration or pulsation;
- the minimum floor area of the room shall be mentioned in the form of a table or a single figure without reference to a formula;
- after completion of field piping for split systems, the field pipework shall be pressure tested with an inert gas and then vacuum tested before refrigerant charging, according to the following requirements:
  - a. The minimum test pressure for the low side of the system shall be the low side design pressure and the minimum test pressure for the high side of the system shall be the high side design pressure, unless the high side of the system can not be isolated from the low side of the system in which case the entire system shall be pressure tested to the low side design pressure.
  - b. The test pressure after removal of the pressure source shall be maintained for at least 1 h with no decrease of pressure indicated by the test gauge, with test gauge resolution not exceeding 5% of the test pressure.
  - c. During the evacuation test, after achieving a vacuum level specified in the manual or less, the refrigeration system shall be isolated from the vacuum pump and the pressure shall not rise above 1500 microns within 10 min. The vacuum pressure level shall be specified in the manual and shall be the lessor of 500 microns or the value required for compliance with national and local codes and standards, which may vary between residential, commercial, and industrial buildings.
- field-made refrigerant joints indoors shall be tightness tested according to the following requirements: The test method shall have a sensitivity of 5 grams per year of refrigerant or better under a pressure of at least 0,25 times the maximum allowable pressure. No leak shall be detected.
- Any servicing shall be performed only as recommended by the manufacturer.

### 3 . Qualification of workers

Any maintenance, service, and repair operations must require the qualification of the working personnel. Every working procedure that affects safety means shall only be carried out by competent technicians who joined the training and achieved competence should be documented by a certificate. The training of these procedures is carried out by national training organizations or manufacturers that are accredited to teach the relevant national competency standards that may be set in legislation. All training shall follow the ANNEX HH requirements of UL 60335-2-40 4th Edition.

Examples of such working procedures are:

- breaking into the refrigerating circuit;
- opening of sealed components;
- opening of ventilated enclosures.

### 4. Ventilated area

Ensure that the area is in the open or that it is adequately ventilated before breaking into the system or conducting any hot work. A degree of ventilation shall continue during the period that the work is carried out. The ventilation should safely disperse any released refrigerant and preferably expel it externally into the atmosphere.

### 5. Wiring

Check that cabling will not be subject to wear, corrosion, excessive pressure, vibration, sharp edges, or any other adverse environmental effects. The check shall also take into account the effects of aging or continual vibration from sources such as compressors or fans.

### 6. Detection of flammable refrigerants

Under no circumstances shall potential sources of ignition be used in the search for or detection of refrigerant leaks. A halide torch (or any other detector using a naked flame) shall not be used.

The following leak detection methods are deemed acceptable for refrigerant systems. Electronic leak detectors may be used to detect refrigerant leaks but, in the case of FLAMMABLE REFRIGERANTS, the sensitivity may not be adequate, or may need re-calibration. (Detection equipment shall be calibrated in a refrigerant-free area.) Ensure that the detector is not a potential source of ignition and is suitable for the refrigerant used. Leak detection equipment shall be set at a percentage of the LFL of the refrigerant and shall be calibrated to the refrigerant employed, and the appropriate percentage of gas (25 % maximum) is confirmed. Leak detection fluids are also suitable for use with most refrigerants but the use of detergents containing chlorine shall be avoided as the chlorine may react with the refrigerant and corrode the copper pipe-work.

### NOTE

Examples of leak-detection fluids are

- bubble method,
- fluorescent method agents.

If a leak is suspected, all naked flames shall be removed/ extinguished.

If leakage of refrigerant is found which requires brazing, all of the refrigerant shall be recovered from the system, or isolated (using shut-off valves) in a part of the system remote from the leak. See the following instructions for the removal of refrigerant.

### 7. Removal and evacuation

When breaking into the refrigerant circuit to make repairs - or for any other purpose conventional procedures shall be used. However, for flammable refrigerants best practice must be followed since flammability is a consideration.

The following procedure shall be adhered to:

- safely remove refrigerant following local and national regulations;
- evacuate;
- purge the circuit with inert gas (optional for A2L);
- evacuate (optional for A2L);

- continuously flush or purge with inert gas when using a flame to open the circuit; and
- open the circuit.

The refrigerant charge shall be recovered into the correct recovery cylinders if venting is not allowed by local and national codes. For appliances containing flammable refrigerants, the system shall be purged with oxygen-free nitrogen to render the appliance safe for flammable refrigerants. This process might need to be repeated several times. Compressed air or oxygen shall not be used for purging refrigerant systems.

For appliances containing flammable refrigerants, refrigerant purging shall be achieved by breaking the vacuum in the system with oxygen-free nitrogen and continuing to fill until the working pressure is achieved, then venting to the atmosphere, and finally pulling down to a vacuum (optional for A2L). This process shall be repeated until no refrigerant is within the system (optional for A2L). When the final oxygen-free nitrogen charge is used, the system shall be vented down to atmospheric pressure to enable work to take place.

The outlet for the vacuum pump shall not be close to any potential ignition sources, and ventilation shall be available.

## 8. Charging procedures

In addition to conventional charging procedures, the following requirements shall be followed:

- Works shall be undertaken with appropriate tools only (In case of uncertainty, please consult the manufacturer of the tools for use with flammable refrigerants) Ensure that contamination of different refrigerants does not occur when using charging equipment. Hoses or lines shall be as short as possible to minimize the amount of refrigerant contained in them.
- Ensure that the refrigeration system is earthed before charging the system with refrigerant.
- Label the system when charging is complete (if not already). Extreme care shall be taken not to overfill the refrigeration system.
- Before recharging the system, it shall be pressure tested with oxygen-free nitrogen (OFN). The system shall be leak tested on completion of charging but before commissioning. A follow-up leak test shall be carried out before leaving the site.

## 9. Recovery

When removing refrigerant from a system, either for servicing or decommissioning, it is recommended good practice that all refrigerants are removed safely.

When transferring refrigerant into cylinders, ensure that only appropriate refrigerant recovery cylinders are employed. Ensure that the correct number of cylinders for holding the total system charge is available. All cylinders to be used are designated.

## Information Servicing

### 1. Checks to the area

Before beginning work on systems containing flammable refrigerants, safety checks are necessary to ensure that the risk of ignition is minimized. For repair to the refrigerating system, the following precautions shall be complied with before conducting work on the system.

### 2. Work procedure

Works shall be undertaken under a controlled procedure to minimize the risk of flammable gas or vapor being present while the work is being performed.

### 3. General work area

All maintenance staff and others working in the local area should be instructed on the nature of the work being carried out. Work in confined spaces shall be avoided.

### 4. Checking for the presence of refrigerant

The area should be checked with an appropriate refrigerant detector before and during work, to ensure the technician is aware of potentially flammable atmospheres. Ensure that the leak detection equipment being used is suitable for use with flammable refrigerants, i.e. no sparking, adequately sealed or intrinsically safe.

### 5. Presence of fire extinguisher

If any hot work is to be conducted on the refrigeration equipment or any associated parts, appropriate fire extinguishing equipment shall be available to hand. Have a dry powder or CO<sub>2</sub> fire extinguisher adjacent to the charging area.

### 6. No ignition sources

No person carrying out work on a REFRIGERATING SYSTEM which involves exposing any pipe work shall use any sources of ignition in such a manner that it may lead to the risk of a fire or explosion. All possible ignition sources, including cigarette smoking, should be kept sufficiently far away from the site of installation, repair, removal, and disposal, during which refrigerant can be released into the surrounding space. Before work takes place, the area around the equipment is to be surveyed to make sure that there are no flammable hazards or ignition risks. "No Smoking" signs shall be displayed.

### 7. Ventilated area

Ensure that the area is in the open or that it is adequately ventilated before breaking into the system or conducting any hot work. A degree of ventilation shall continue during the period that the work is carried out. The ventilation should safely disperse any released refrigerant and preferably expel it externally into the atmosphere.

### 8. Check the refrigeration equipment

Where electrical components are being changed, they shall be fit for the purpose and to the correct specification. At all times the manufacturer's maintenance and service guidelines shall be followed. If in doubt consult the manufacturer's technical department for assistance. The following checks shall be applied to installations using FLAMMABLE REFRIGERANTS:

- the actual refrigerant charge is in accordance with the room size within which the refrigerant-containing parts are installed;
- the ventilation machinery and outlets are operating adequately and are not obstructed;
- if an indirect refrigerating circuit is being used, the secondary circuits shall be checked for the presence of refrigerant;
- marking to the equipment continues to be visible and legible, marking and illegible signs shall be corrected;
- refrigeration pipe or components are installed in a position where they are unlikely to be exposed to any substance that may corrode refrigerant-containing components

unless the components are constructed of materials that are inherently resistant to being corroded or are suitably protected against being so corroded.

#### **9. Checks of electrical devices**

Repair and maintenance of electrical components shall include initial safety checks and component inspection procedures. If a fault exists that could compromise safety, then no electrical supply shall be connected to the circuit until it is satisfactorily dealt with. If the fault cannot be corrected immediately it is necessary to continue operation, and adequate temporary solution shall be used.

This shall be reported to the owner of the equipment so all parties are advised.

##### **Initial safety checks shall include:**

that capacitors are discharged: this shall be done safely to avoid the possibility of sparking;

that no live electrical components and wiring are exposed while charging, recovering, or purging the system;

that there is continuity of earth bonding;

Sealed electrical components shall be replaced if it's damaged; Intrinsically safe components must be replaced if it's damaged.

#### **10. Sealed electrical components shall be replaced.**

#### **11. Intrinsically safe components must be replaced.**

#### **12. Cabling**

Check that cabling will not be subject to wear, corrosion, excessive pressure, vibration, sharp edges, or any other adverse environmental effects. The check shall also consider the effects of aging or continual vibration from sources such as compressors or fans.

#### **13. Detection of flammable refrigerants**

Under no circumstances shall potential sources of ignition be used in the search for or detection of refrigerant leaks. A halide torch (or any other detector using a naked flame) shall not be used.

The following leak detection methods are deemed acceptable for refrigerant systems. Electronic leak detectors may be used to detect refrigerant leaks but, in the case of FLAMMABLE REFRIGERANTS, the sensitivity may not be adequate, or may need re-calibration. (Detection equipment shall be calibrated in a refrigerant-free area.) Ensure that the detector is not a potential source of ignition and is suitable for the refrigerant used. Leak detection equipment shall be set at a percentage of the LFL of the refrigerant and shall be calibrated to the refrigerant employed, and the appropriate percentage of gas (25 % maximum) is confirmed.

Leak detection fluids are also suitable for use with most refrigerants but the use of detergents containing chlorine shall be avoided as the chlorine may react with the refrigerant and corrode the copper pipe-work.

#### **NOTE**

Examples of leak-detection fluids are:

- bubble method,
- fluorescent method agents.

If a leak is suspected, all naked flames shall be removed/extinguished.

If a leakage of refrigerant is found which requires brazing, all of the refrigerant shall be recovered from the system, or isolated (utilizing shut of valves) in a part of the system

remote from the leak. See the following instructions for the removal of refrigerant.

#### **14. Removal and evacuation**

When breaking into the refrigerant circuit to make repairs - or for any other purpose conventional procedures shall be used. However, for flammable refrigerants best practice must be followed since flammability is a consideration.

The following procedure shall be adhered to:

- safely remove refrigerant following local and national regulations;
- evacuate;
- purge the circuit with inert gas (optional for A2L);
- evacuate (optional for A2L);
- continuously flush or purge with inert gas when using a flame to open the circuit; and
- open the circuit

The refrigerant charge shall be recovered into the correct recovery cylinders if venting is not allowed by local and national codes. For appliances containing flammable refrigerants, the system shall be purged with oxygen-free nitrogen to render the appliance safe for flammable refrigerants. This process might need to be repeated several times. Compressed air or oxygen shall not be used for purging refrigerant systems.

For appliances containing flammable refrigerants, refrigerant purging shall be achieved by breaking the vacuum in the system with oxygen-free nitrogen and continuing to fill until the working pressure is achieved, then venting to the atmosphere, and finally pulling down to a vacuum (optional for A2L). This process shall be repeated until no refrigerant is within the system (optional for A2L). When the final oxygen-free nitrogen charge is used, the system shall be vented down to atmospheric pressure to enable work to take place.

The outlet for the vacuum pump shall not be close to any potential ignition sources, and ventilation shall be available.

#### **15. Charging procedures**

In addition to conventional charging procedures, the following requirements shall be followed:

- Works shall be undertaken with appropriate tools only (In case of uncertainty, please consult the manufacturer of the tools for use with flammable refrigerants)
- Ensure that contamination of different refrigerants does not occur when using charging equipment. Hoses or lines shall be as short as possible to minimize the amount of refrigerant contained in them.
- Cylinders shall be kept upright.
- Ensure that the refrigeration system is earthed before charging the system with refrigerant.
- Label the system when charging is complete (if not already).
- Extreme care shall be taken not to overfill the refrigeration system.
- Before recharging the system, it shall be pressure tested with oxygen-free nitrogen (OFN). The system shall be leak tested on completion of charging but before commissioning. A follow-up leak test shall be carried out before leaving the site.

#### **16. Decommissioning**

Before carrying out this procedure, the technician must be

completely familiar with the equipment and all its details. It is recommended good practice that all refrigerants are recovered safely. Before the task is carried out, an oil and refrigerant sample shall be taken in case analysis is required before the re-use of recovered refrigerant. Electrical power must be available before the task commences.

- a. Become familiar with the equipment and its operation.
- b. Isolate system electrically
- c. Before attempting the procedure ensure that:
  - mechanical handling equipment is available, if required, for handling refrigerant cylinders;
  - all personal protective equipment is available and being used correctly;
  - the recovery process is supervised at all times by a competent person;
  - recovery equipment and cylinders conform to the appropriate standards.
- d. Pump down the refrigerant system, if possible.
- e. If a vacuum is not possible, make a manifold so that refrigerant can be removed from various parts of the system.
- f. Make sure that the cylinder is situated on the scales before recovery takes place.
- g. Start the recovery machine and operate following instructions.
- h. Do not overfill cylinders (no more than 80 % volume liquid charge)
- i. Do not exceed the maximum working pressure of the cylinder, even temporarily.
- j. When the cylinders have been filled correctly and the process completed, make sure that the cylinders and the equipment are removed from the site promptly and all isolation valves on the equipment are closed off.
- k. Recovered refrigerant shall not be charged into another refrigeration system unless it has been cleaned and checked.

**17. Labelling**

Equipment shall be labeled stating that it has been de-commissioned and emptied of refrigerant. The label shall be dated and signed. For appliances containing FLAMMABLE REFRIGERANTS, ensure that there are labels on the equipment stating the equipment contains FLAMMABLE REFRIGERANT.

**18. Recovery**

When removing refrigerant from a system, either for servicing or decommissioning, it is recommended good practice that all refrigerants are removed safely.

When transferring refrigerant into cylinders, ensure that only appropriate refrigerant recovery cylinders are employed. Ensure that the correct number of cylinders for holding the total system charge is available. All cylinders to be used are designated for the recovered refrigerant and labeled for that refrigerant (i.e., special cylinders for the recovery of refrigerant). Cylinders shall be complete with pressure-relief valves and associated shut-off valves in good working order. Empty recovery cylinders are evacuated and, if possible, cooled before recovery occurs.

The recovery equipment shall be in good working order with a set of instructions concerning the equipment that is at hand and shall be suitable for the recovery of the

flammable refrigerant. If in doubt, the manufacturer should be consulted. In addition, a set of calibrated weighing scales shall be available and in good working order. Hoses shall be complete with leak-free disconnect couplings and in good condition.

The recovered refrigerant shall be processed according to local legislation in the correct recovery cylinder, and the relevant waste transfer note arranged. Do not mix refrigerants in recovery units especially not in cylinders.





If compressors or compressor oils are to be removed, ensure that they have been evacuated to an acceptable level to make certain that flammable refrigerant does not remain within the lubricant. The compressor body shall not be heated by an open flame or other ignition sources to accelerate this process. When oil is drained from a system, it shall be carried out safely.

**19. Transportation, marking, and storage for units**

1. **Transport of equipment containing flammable refrigerants** - Compliance with the transport regulations.
2. **Marking of equipment using signs** - Compliance with the transport regulations.
3. **Disposal of equipment using flammable refrigerants** - Compliance with national regulations.
4. **Storage of equipment/appliances** - The storage of the appliance should be following the applicable regulations or instructions, whichever is more stringent.
5. **Storage of packed (unsold) equipment** - Storage package protection should be constructed in such a way that mechanical damage to the equipment inside the package will not cause a leak of the REFRIGERANT CHARGE.

The maximum number of pieces of equipment permitted to be stored together will be determined by local regulations.

**Table S-3: Explanation of symbols displayed on the indoor unit or outdoor unit**

	<b>WARNING</b>	This symbol shows that this appliance used a flammable refrigerant. If the refrigerant is leaked and exposed to an external ignition source, there is a risk of fire.
	<b>CAUTION</b>	This symbol shows that the operation manual should be read carefully.
	<b>CAUTION</b>	This symbol shows that service personnel should be handling this equipment referencing the installation manual.
	<b>CAUTION</b>	This symbol shows that information is available such as the operating manual or installation manual.

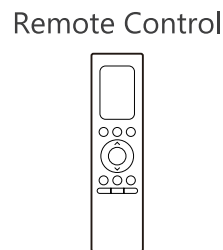
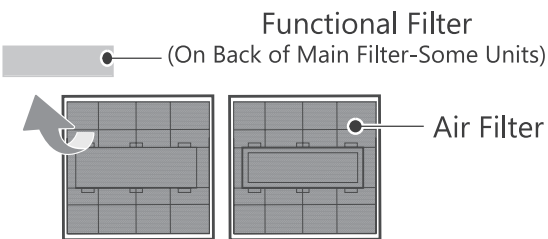
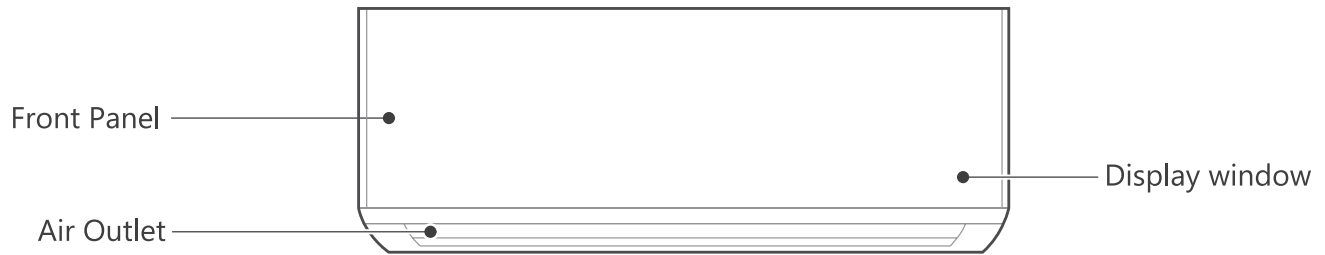
# Specification

<b>Product Model</b>	<b>MSGNS-H09B-1A MO1BS-H09B-1A</b>		<b>MSGNS-H12B-1A MO1BS-H12B-1A</b>	
Power source	115 V~60 Hz,1 Ph			
Cooling capacity	9,000 Btu/h		12,000 Btu/h	
Heating capacity	10,000 Btu/h		12,000 Btu/h	
Moisture resistance class	IPX4			
<b>Product Model</b>	<b>MSGNS-H09B-2A MO1BS-H09B-2A</b>	<b>MSGNS-H12B-2A MO1BS-H12B-2A</b>	<b>MSGNS-H18B-2A MO1BS-H18B-2A</b>	
Power source	208/230 V~ 60 Hz, 1 Ph			
Cooling capacity	9,000 Btu/h	12,000 Btu/h	18,000 Btu/h	
Heating capacity	10,000 Btu/h	12,000 Btu/h	18,800 Btu/h	
Moisture resistance class	IPX4			
<b>Product Model</b>	<b>MSGNS-H24B-2A MO1BS-H24B-2A</b>	<b>MSGNS-H30B-2A MO1BS-H30B-2A</b>	<b>MSGNS-H36B-2A MO1BS-H36B-2A</b>	
Power source	208/230 V~ 60 Hz, 1 Ph			
Cooling capacity	24,000 Btu/h	30,000 Btu/h	36,000 Btu/h	
Heating capacity	24,000 Btu/h	30,000 Btu/h	36,000 Btu/h	
Moisture resistance class	IPX4			

# Get to Know Your AC

## NOTE

- Different models have different front panels and display windows. Not all the indicators described below are available for the air conditioner you purchased. Please check the indoor display window of the unit you purchased.
- Illustrations in this manual are for explanatory purposes. The actual shape of your indoor unit may be slightly different. The actual shape shall prevail.



## Indoor Unit Display

<b>Display Window</b>	
<b>Display Code</b>	<b>Display Code Meaning</b>
<b>88</b>	<ul style="list-style-type: none"> <li>• Displays temperature, operation feature, and Error codes.</li> </ul>
	<ul style="list-style-type: none"> <li>• When the Wireless Control feature is activated (For App control units).</li> </ul>
<b>ON</b> (for 3 seconds when)	<ul style="list-style-type: none"> <li>• TIMER ON is set (if the unit is OFF, "ON" remains on when TIMER ON is set ).</li> <li>• WING, TURBO, ECO, BREEZE AWAY, SILENCE, or ECO INTELLIGENT EYE feature is turned on.</li> </ul>
<b>OF</b> (for 3 seconds when)	<ul style="list-style-type: none"> <li>• TIMER OFF is set.</li> <li>• SWING, TURBO, ECO, BREEZE AWAY, SILENCE, or ECO INTELLIGENT EYE feature is turned off.</li> </ul>
<b>CL</b>	<ul style="list-style-type: none"> <li>• When the Active Clean feature is turned on.</li> </ul>
<b>dF</b>	<ul style="list-style-type: none"> <li>• When defrosting.</li> </ul>
<b>FP</b>	<ul style="list-style-type: none"> <li>• When 46°F (8°C) heating feature is turned on.</li> </ul>

## More Features

### NOTE

Every time the air conditioner is powered on, a buzzing sound will be heard to indicate that the product has been powered on normally. If there is no sound, the unit may be abnormal. Please power it on again or check the circuit. The actual functions are subject to the product you purchased, please check the indoor display and remote control of your AC. See the <Remote Controller Manual> for more features.

- **Auto-Restart**

If the unit loses power, it will automatically restart with the prior settings once power has been restored.

- **Breeze Away**

This feature prevents direct airflow from blowing on the body, creating a sensation of silky coolness.

- **Wireless Control (For App control units)**

Wireless control allows you to control your air conditioner using your mobile phone and a wireless connection. For the USB device access, replacement, and maintenance operations must be carried out by professional staff.

- **Active Clean function**

- The Active Clean Technology washes away dust when it adheres to the heat exchanger by automatically freezing and then rapidly thawing the frost. A "pi-pi" sound will be heard.

- The Active clean operation is used to produce more condensed water to improve the cleaning effect, and the cold air will blow out. After cleaning, the internal wind wheel then keeps operating with hot air to blow dry the evaporator, thus keeping the inside clean.

- When this function is turned on, the indoor unit display window appears "CL ", after 20 to 45 minutes, the unit will turn off automatically and cancel the Active Clean function.

- **Louver Angle Memory**

When turning on your unit, the louver will automatically resume its former angle.

- **Heat exchanger dust removal function:**

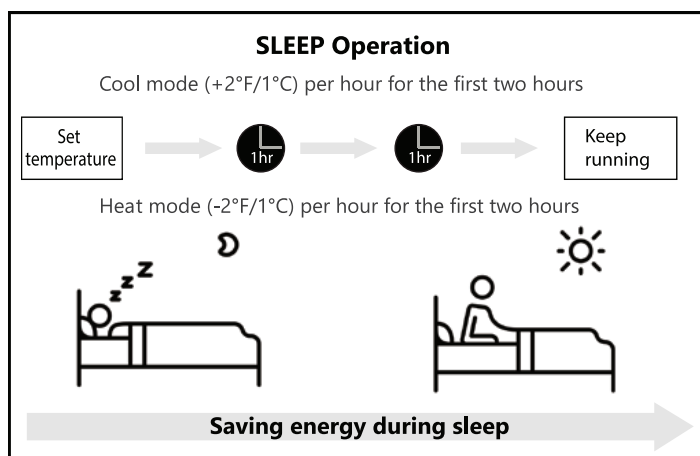
This feature helps keep the outdoor coil cleaner and may extend the duration between regular maintenance intervals depending on local conditions. When the unit is turned off, a 10-second delay occurs then the outdoor fan runs in reverse rotation for 70 seconds to blow off loose accumulated dust and debris.

- **Refrigerant Leakage Detection**

- When the system detects a malfunction of the refrigerant, the indoor unit will automatically display the following error codes: "EL0C (System lacks refrigerant )", "EHC1(Refrigerant sensor detects leakage)", "EHC2 (Working condition of the refrigerant the sensor is out of range and leakage is detected)", "EHC3(Working condition of the refrigerant sensor is out of range)", or "ECC1(Other indoor unit refrigerant sensor detects leakage (Multi-zone))".

- When the "EHC1" or "EHC2" error occurs, the buzzer will continue to beep for 5 to 6 minutes before stopping. You can also press any button on the remote controller to stop the buzzer.

- Note: Error codes of "EHC1", "EHC2", "EHC3" and "ECC1" are only applicable to the units with refrigerant sensor.



- **Sleep Operation**

The SLEEP function is used to decrease energy use while you sleep (and don't need the same temperature settings to stay comfortable).

Press the **SLEEP** button on remote control when in COOL mode, the unit will increase the temperature by 2°F (1°C) after 1 hour, and will increase an additional 2°F (1°C) after another hour.

When in HEAT mode, the unit will decrease the temperature by 2°F (1°C) after 1 hour, and will decrease an additional 2°F (1°C) after another hour.

The sleep feature will stop after 8 hours and the system will keep running with final situation.

## Setting Airflow Angle

### NOTE

#### Setting the vertical angle of airflow (Remote control)

While the unit is on, use the SWING button on the remote control to set the direction (vertical/horizontal angle) of airflow. Please refer to the Remote Control Manual for details.

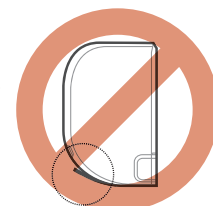
### NOTE

#### ON LOUVER ANGLES

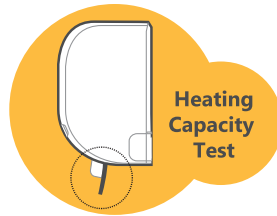
- Do not set louver at too vertical an angle for long periods of time When using COOL or DRY mode. It would be condensing the water on the louver blade, which will drop on your floor or furnishings.



- Setting the louver at too small an angle when using COOL or HEAT mode, can reduce the performance of the AC due to restricted airflow.



- According to the relative standards requirement, please set the vertical air flow louver to its maximum angle under the heating capacity test



## NOTE

Do not move the louver by hand. You can turn off the unit and unplug it for a few seconds to restart the unit. It will reset the louver when it powers back on.

## CAUTION

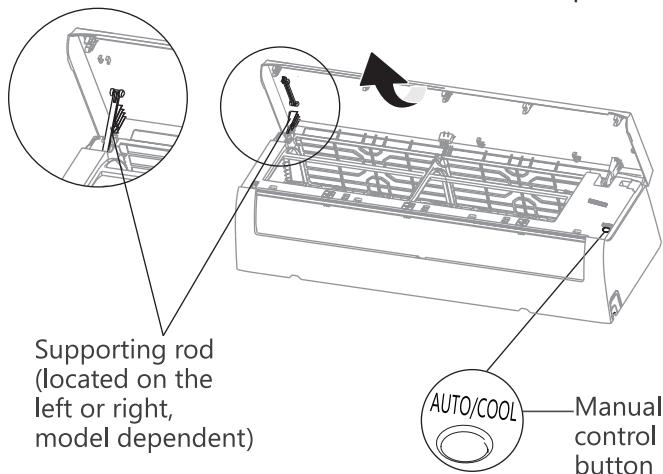
Do not put your fingers in or near the blower and suction side of the unit. The high-speed fan inside the unit may cause injury.

# Manual Operation

(without the remote)

## CAUTION

The manual button is intended for testing purposes and emergency operations only. Please do not use this function unless the remote control is lost and it is necessary. To restore regular operation, use the remote control to activate the unit. The unit must be turned off before manual operation.



### To operate your unit manually:

1. Open the front panel of the indoor unit.

## NOTE

If there is a supporting rod located on the left or right side. Please use it to prop up the panel.

2. Locate the **MANUAL CONTROL** button on the right-hand side of the unit.
3. Press the **MANUAL CONTROL** button one time to activate the FORCED AUTO mode.
4. Press the **MANUAL CONTROL** button again to activate the FORCED COOLING mode.
5. Press the **MANUAL CONTROL** button a third time to turn the unit off.
6. Release the supporting rod (if any), then close the front panel.

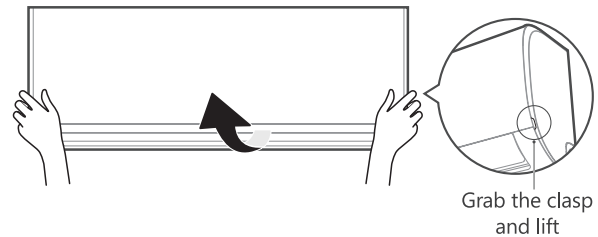
# Care & Maintenance

## CAUTION

- The cooling efficiency of your unit and your health would be damaged by the clogged AC. Make sure to clean the filter every two weeks.
- Always **TURN OFF** your AC system and disconnect its power supply before cleaning or maintenance.
- **Do not** touch the air freshening (Plasma) filter at least 10 minutes after turning off the unit.
- Only use a soft, dry cloth to wipe the unit clean. You can use a cloth soaked in warm water to wipe it clean if the unit is especially dirty.
- **Do not** use chemicals or chemically treated cloths to clean the unit
- **Do not** use benzene, paint thinner, polishing powder, or other solvents to clean the unit. They can cause the plastic surface to crack or deform.
- **Do not** use water hotter than 104°F (40°C) to clean the front panel. This can cause the panel to deform or become discolored.

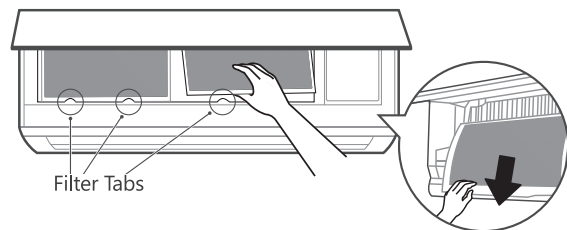
### Cleaning Your Indoor Unit's Air Filter

1. Lift the front panel of the indoor unit. For the unit with a supporting rod, please use it to prop up the front panel.



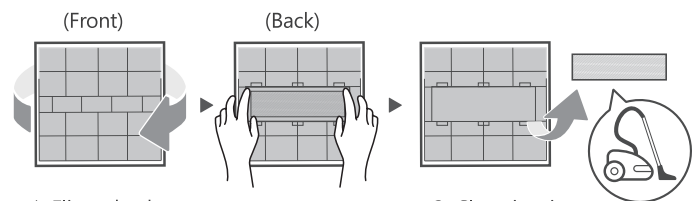
Grab the clasp and lift

2. Grip the tab at the end of the filter, lift it, then pull it towards yourself and pull the filter out.



Filter Tabs

3. If your filter has a small air freshening filter, unclip it from the larger filter. Clean this air freshening filter with a hand-held vacuum.

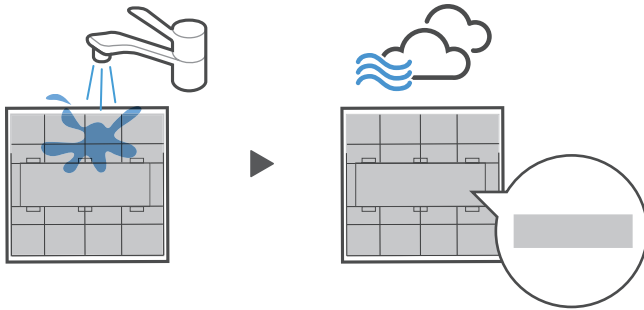


1. Flip to back

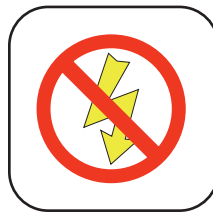
2. Remove air freshening filter off

3. Clean it using a vacuum cleaner

4. Clean the large air filter with warm, soapy water. Be sure to use a mild detergent. Rinse the filter with fresh water, then shake off excess water. Dry it in a cool, dry place, and refrain from exposing it to direct sunlight.

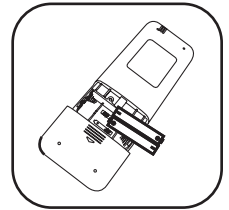


5. When dry, re-clip the air freshening filter to the larger filter, then install the air filter back on the top of the indoor unit.



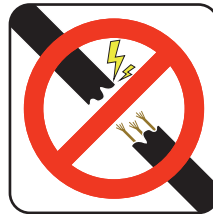
3. Turn the unit off and disconnect the power.

4. Remove the batteries from the remote control.



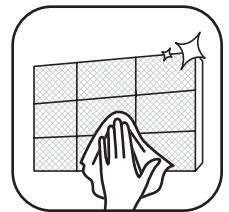
**Pre-Season Inspection**

After long periods of non-use, or before periods of frequent use, do the following:

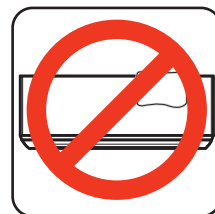


1. Check for damaged wires.

2. Clean all of the filters.

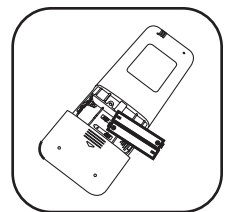


3. Check for leaks.



4. Make sure nothing is blocking all air inlets and outlets.

5. Replace the remote control batteries.



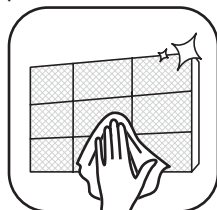
**⚠ CAUTION**

- Before changing the filter or cleaning, turn off the unit and disconnect its power supply.
- When removing the filter, do not touch metal parts in the unit. The sharp metal edges can cut you.
- Do not use water to clean the inside of the indoor unit. This can destroy insulation and cause electrical shock.
- Do not expose the filter to direct sunlight when drying. This can shrink the filter.
- Any maintenance and cleaning of the outdoor unit should be performed by an authorized dealer or a licensed service provider.
- Any unit repairs should be performed by an authorized dealer or a licensed service provider.

**Maintenance of your AC**

**Long Periods of Non-Use**

If you plan not to use your air conditioner for an extended period, do the following:



1. Clean all of the filters.

2. Turn on FAN function until the unit dries completely



# Troubleshooting

## ⚠ CAUTION

If any of the following conditions occur, turn off your unit immediately!

- The wire is damaged or abnormally warm
- You smell a burning odor
- The unit emits loud or abnormal sounds
- A power fuse blows or the circuit breaker frequently trips
- Water or other objects fall into or out of the unit

**DO NOT ATTEMPT TO FIX THESE YOURSELF! CONTACT AN AUTHORIZED SERVICE PROVIDER IMMEDIATELY.**

### Common Issues

The following problems are not malfunctions and, in most situations, will not require repairs.

Issue	Possible Causes
The unit does not turn on when pressing the ON/OFF button	The Unit has a 3-minute protection feature that prevents the unit from overloading. The unit cannot be restarted within three minutes of being turned off.
The unit changes from COOL/HEAT mode to FAN mode	The unit may change its setting to prevent frost from forming on the unit. Once the temperature increases, the unit will start operating in the previously selected mode again.
	Once the set temperature has been reached, the unit turns off the compressor. It will continue operating when the temperature fluctuates again.
The indoor unit emits a white mist	In humid regions, a large temperature difference between the room's air and the conditioned air can cause white mist.
Both the indoor and outdoor units emit white mist	When the unit restarts in HEAT mode after defrosting, a white mist may be emitted due to moisture generated from the defrosting process.
The indoor unit makes noises	A rushing air sound may occur when the louver resets its position.
	A squeaking sound may occur after running the unit in HEAT mode due to the expansion and contraction of the unit's plastic parts.
Both the indoor unit and outdoor unit make noises	Low hissing sound during operation: This is normal and is caused by refrigerant gas flowing through both indoor and outdoor units
	Low hissing sound when the system starts, has just stopped running, or is defrosting: This noise is normal and is caused by the refrigerant gas stopping or changing direction.
	Squeaking sound: Normal expansion and contraction of plastic and metal parts caused by temperature changes during operation can cause squeaking noises.
The outdoor unit makes noises	The unit will make different sounds based on its current operating mode.
Dust is emitted from either the indoor or outdoor unit	The unit may accumulate dust during extended periods of non-use, which will be emitted when the unit is turned on. This can be mitigated by covering the unit during long periods of inactivity.
The unit emits a bad odor	The unit may absorb odors from the environment (such as furniture, cooking, cigarettes, etc.) which will be emitted during operations.
	The unit's filters have become moldy and should be cleaned.
The fan of the outdoor unit does not operate	During operation, the fan speed is controlled to optimize product operation.
Operation is erratic, unpredictable, or the unit is unresponsive	Interference from cell phone towers and remote boosters may cause the unit to malfunction. In this case, try the following: <ul style="list-style-type: none"> <li>• Disconnect the power, then reconnect.</li> <li>• Press the ON/OFF button on the remote control to restart the operation.</li> </ul>

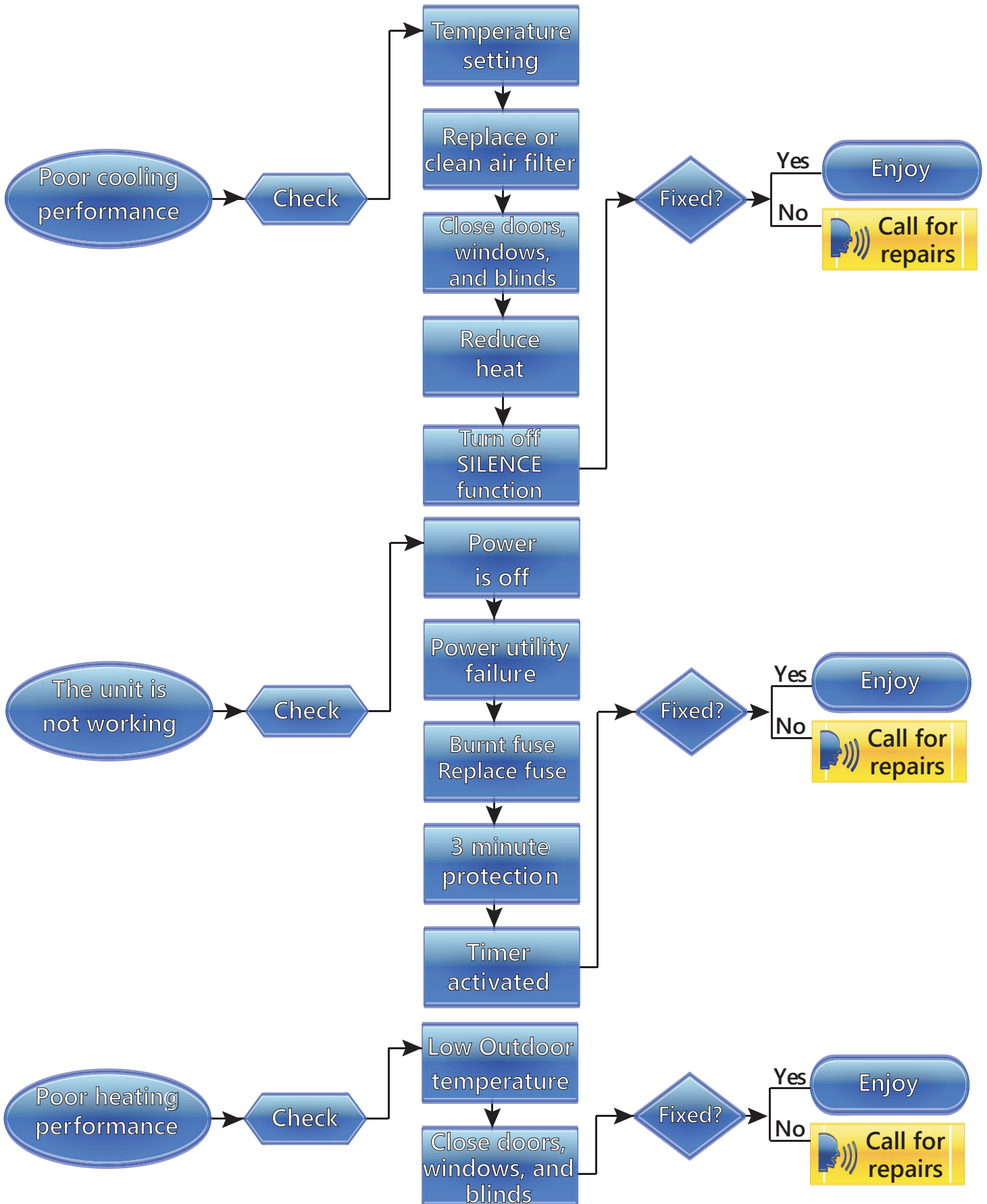
### NOTE

If the problem persists, contact a local dealer. Provide them with a detailed description of the unit malfunction as well as your model number.

# When To Call For Repairs

**⚠ CAUTION**

When troubles occur, please check the following points before contacting a repair company.



# Install Your Indoor Unit




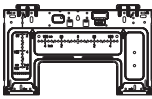






## Table of Contents

<b>Installation Accessories .....</b>	<b>18</b>
Table A-1: Included Accessories.....	18
Table A-2: Optional Accessories.....	18
Table A-3: Connecting Pipe Specifications.....	18
Unpacking.....	18
<b>Product Overview .....</b>	<b>19</b>
Fig. P-1: Component Location.....	19
<b>Installation Summary - Indoor Unit.....</b>	<b>20</b>
<b>Installation Location .....</b>	<b>22</b>
<b>Installation .....</b>	<b>23</b>
Step 1 - Mounting Plate.....	23
Fig. 1-1: Remove the Mounting Bracket.....	23
Fig. 1-2: Install the Mounting Plate .....	23
Fig. 1-3: Unit Dimensions .....	23
Step 2 - Drill Wall Hole .....	24
Fig. 2-1: Drill Core Sizes.....	24
Fig. 2-2: Drill At Downward Angle.....	24
Fig. 2-3: Install the Protective Cuff.....	24
Step 3 - Refrigerant Pipe & Drain Hose .....	24
Fig. 3-1: Choose Exit Direction for Piping .....	24
Fig. 3-2: Knock-Out Panel Location .....	25
Fig. 3-3: Drain Hose Placement.....	25
Fig. 3-4: Drain Hose Routing .....	25
Step 4 - Electrical work preparation .....	26
Fig. 4-1: Wiring Diagrams.....	26
Fig. 4-2: Wiring Routing .....	27
Step 5 - Wrap Piping & Cables.....	27
Fig. 5-1: Bundle Arrangement.....	27
Fig. 5-2: Wrap The Bundle With Vinyl Tape .....	27
Step 6 - Mount Indoor Unit.....	28
Fig. 6-1: Mount the Unit to the Wall Bracket.....	28
Fig. 6-2: A-B Pipe Connection.....	28

# Installation Accessories

The air conditioning system comes with the following accessories: Use all of the installation parts and accessories to install the air conditioner. Improper installation may result in water leakage, electrical shock, fire, or equipment failure. The items not included with the air conditioner must be purchased separately.



**Table A-1: Included Accessories**

QTY.	Part Name	Part Image
2-3	Manual	
1	Drain joint	
1	Seal	
1+1	Mounting plate+ Cardboard template	
5	Anchor	
5	Mounting plate screw	
2	Copper nut NOTE: Used to connect the connecting pipes between indoor and outdoor units.	
1	Remote controller	
2	Batteries	
1-2	Small Filter (Needs to be installed on the back of the main air filter by the authorized technician while installing the machine)	

## NOTE

In the North American market, when a 33K hyper heat indoor unit matches with multi-zone condensers, you must purchase pipe with liquid side 3/8 in. (9.52 mm) and gas side 5/8 in. (16mm). The transfer connector needs to be installed on the indoor unit gas side to meet the pipe size.

**Table A-2: Optional Accessories**

QTY.	Part Name	Part Image
1	Remote control holder	
2	Screws to mount the remote control holder	

**Table A-3: Connecting Pipe Specifications**

Model	Pipe specification	
	Liquid side	Gas side
6K	Ø1/4 in. (Ø6.35 mm)	Ø3/8 in. (Ø9.52 mm)
9K	Ø1/4 in. (Ø 6.35 mm)	Ø3/8 in. (Ø9.52 mm)
12K	Ø1/4 in. (Ø6.35 mm)	Ø3/8 in. (Ø9.52 mm)
18K	Ø1/4 in. (Ø6.35 mm)	Ø1/2 in. (Ø12.7 mm)
24K	Ø3/8 in. (Ø9.52 mm)	Ø5/8 in. (Ø16 mm)
30K	Ø3/8 in. (Ø9.52 mm)	Ø5/8 in. (Ø16 mm)
33K	Ø3/8 in. (Ø9.52 mm)	Ø3/4 in. (Ø19 mm)
36K	Ø3/8 in. (Ø9.52 mm)	Ø5/8 in. (Ø16 mm)

## NOTE

These parts must be purchased separately. Consult the dealer about the proper pipe size of the unit you purchased.

# Unpacking

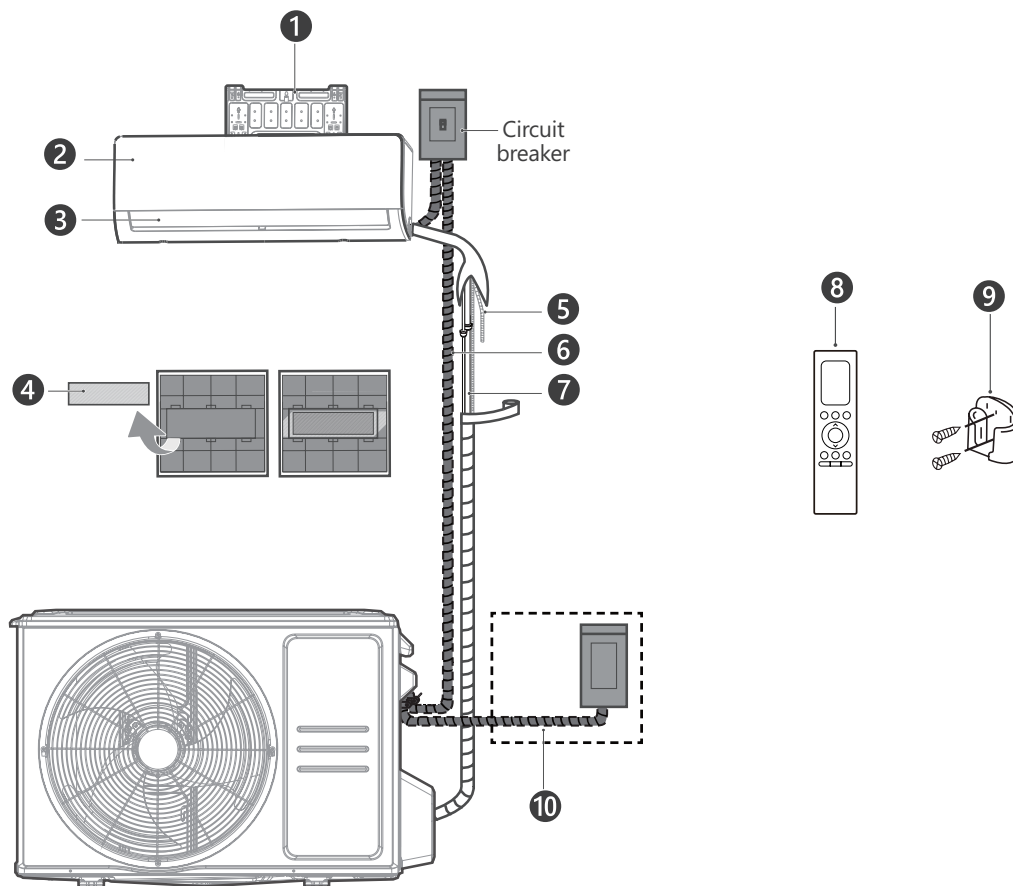
## Indoor unit:

1. Cut the sealing tape on the carton with a knife, one cut on the left, one cut in the middle and one cut on the right.
2. Use the vice to take out the sealing nails on the top of the carton.
3. Open the carton.
4. Take out the middle support plate if it is included.
5. Take out the accessory package and take out the connecting wire if it is included.
6. Lift the machine out of the carton and lay it flat.
7. Remove the left and right package foam or the upper and lower packaging foam, untie the packaging bag.

## Outdoor Unit

1. Cut the packing belt.
2. Take the unit out of the carton.
3. Remove the foam from the unit.
4. Remove the packaging bag from the unit.

# Product Overview



- ① Wall Mounting Plate
- ② Front Panel
- ③ Louver
- ④ Air Filter
- ⑤ Drain Pipe (purchase separately)
- ⑥ Connection Cable (purchase separately)
- ⑦ Refrigerant Piping (purchase separately)
- ⑧ Remote Control
- ⑨ Remote control Holder (purchase separately)
- ⑩ Outdoor Unit Power Cable (purchase separately)

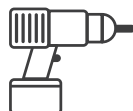
## Tools you will need to install the air conditioner



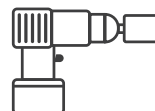
Gloves



Screwdriver & wrench



Hammer drill



Core drill



Goggles & masks



Vinyl tape

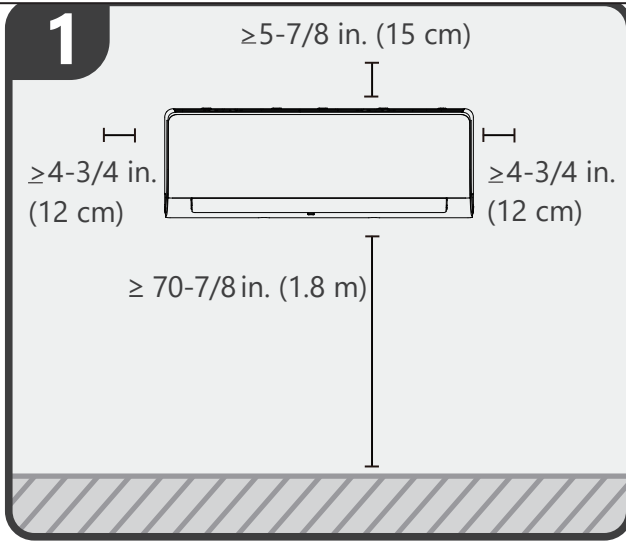
Fig. P-1: Component Location

### NOTE

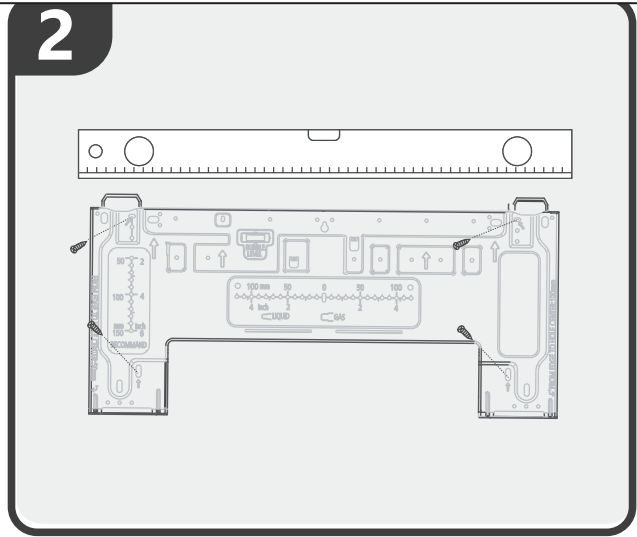
Illustrations in this manual are for explanatory purposes. The actual shape of your indoor unit may be slightly different. The actual shape shall prevail.

The installation must be performed following the requirements of local and national standards. The installation may be slightly different in different areas.

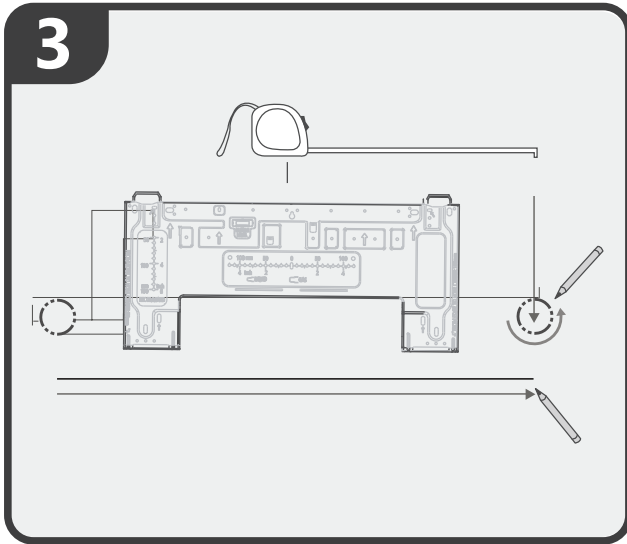
# Installation Summary - Indoor Unit



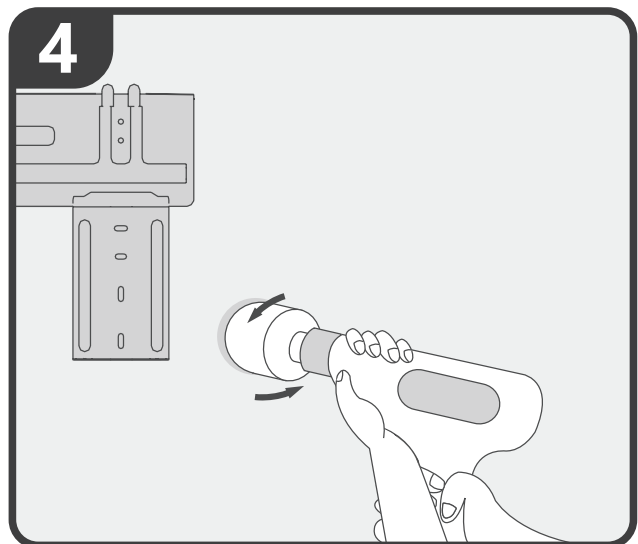
Select Installation Location



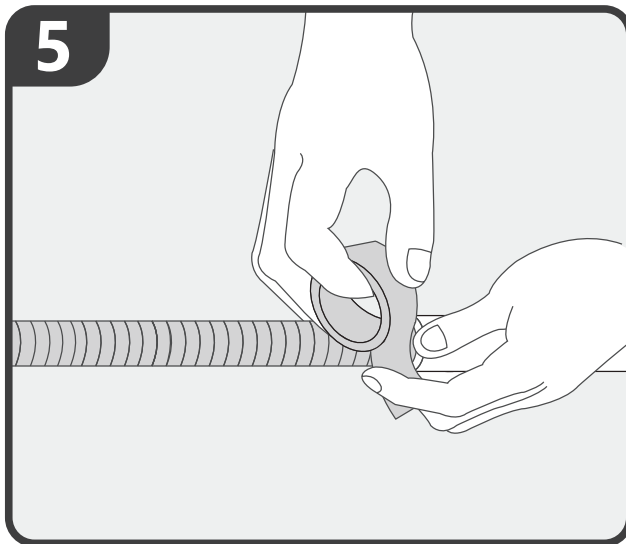
Attach Mounting Plate



Determine Wall Hole Position

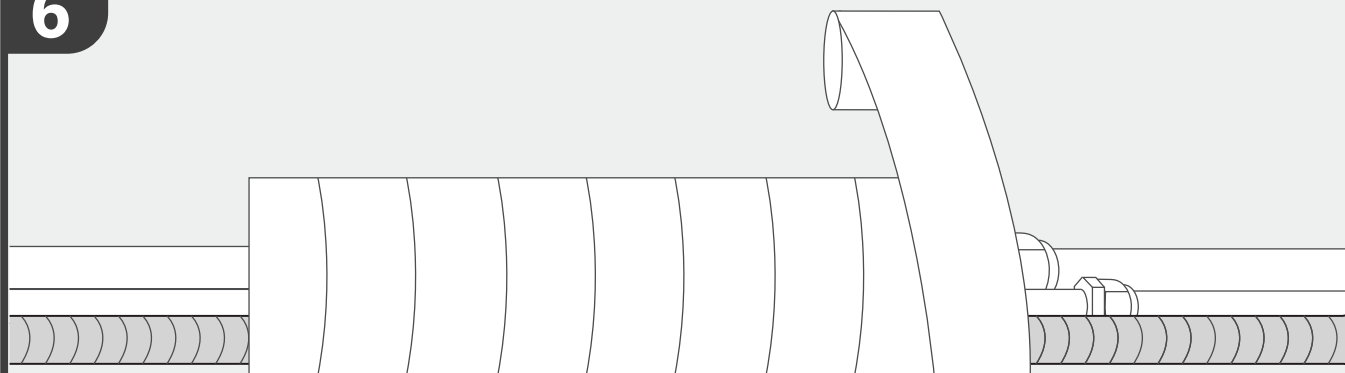


Drill Wall Hole



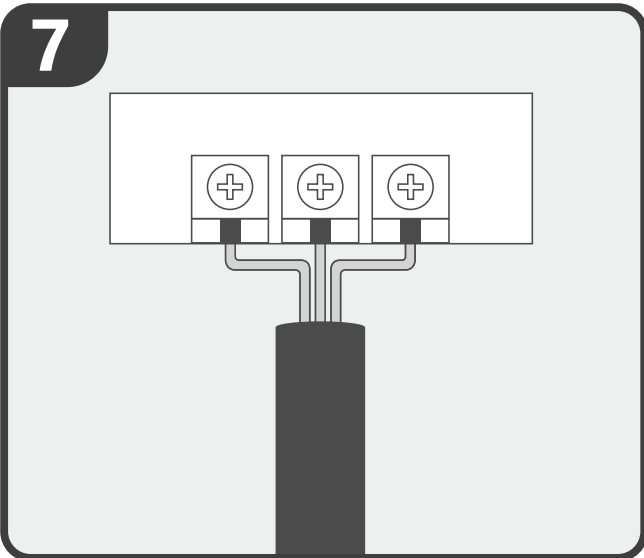
Prepare Drain Hose

6



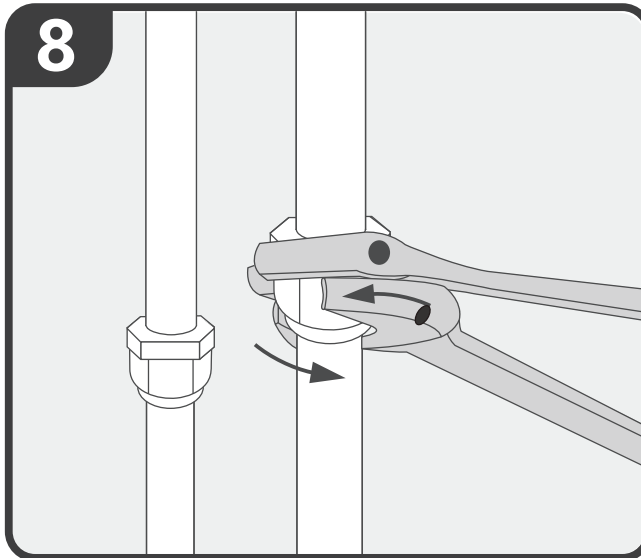
Wrap Piping and drain hose

7



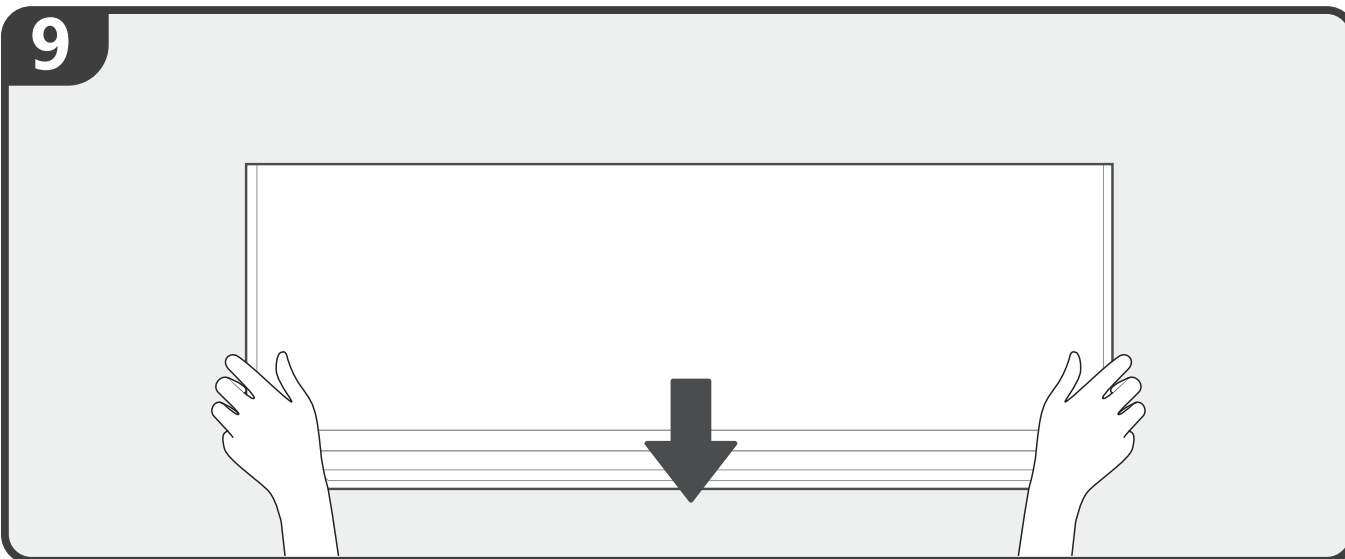
Connect Wiring

8



Connect Piping

9



Mount Indoor Unit

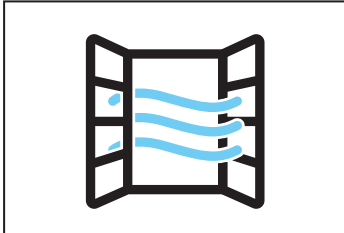
# Installation Location

## NOTE

Before installing the indoor unit, refer to the label on the product box to ensure that the indoor unit's model number matches the outdoor unit's model number.

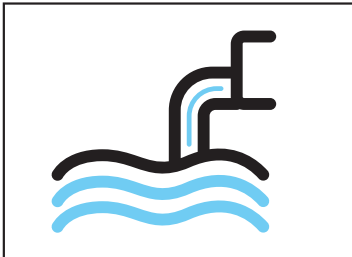
The following are standards that will help you choose an appropriate location for the unit.

**PROPER INSTALLATION LOCATIONS MUST MEET THE FOLLOWING STANDARDS:**



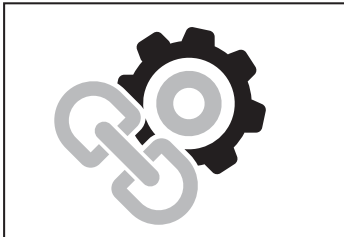
Good air circulation

Convenient drainage



Noise from the unit will not disturb other people.

A location at least one meter from all other electrical devices (e.g., TV, radio, computer)



Firm and solid—the location will not vibrate. Strong enough to support the weight of the unit.

## DO NOT INSTALL IN THE FOLLOWING LOCATIONS:

- Near any source of heat, steam, or combustible gas
- Near flammable items such as curtains or clothing
- Near any obstacle that might block air circulation
- Near a doorway.
- In a location subject to direct sunlight.

## NOTE

### FOR PRODUCT INSTALLATION

If there is no fixed refrigerant piping:

While choosing a location, be aware that you should leave ample room for a wall hole (see Drill wall hole for connecting piping step) for the signal cable and refrigerant piping that connect the indoor and outdoor units. The default position for all piping is the right side of the indoor unit (while facing the unit). However, the unit can accommodate piping to both the left and right.

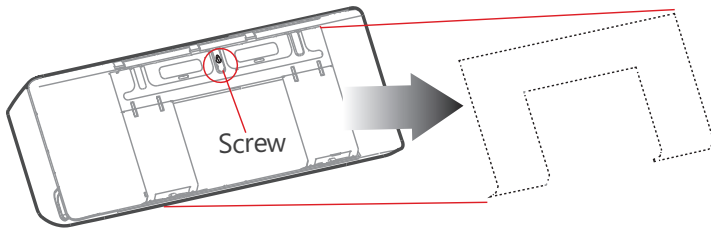
# Installation

## Step 1 - Mounting Plate

### NOTE

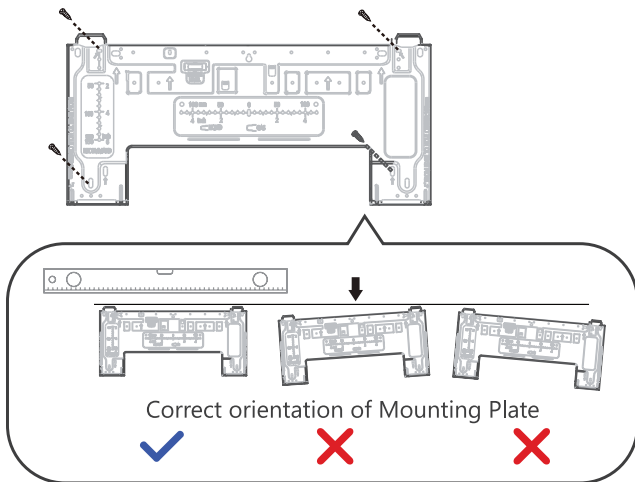
The size of the wall hole is determined by the connecting pipes. When the pipe size of the gas side is  $\text{Ø}5/8$  in. ( $\text{Ø}16$  mm) or more, the wall hole should be  $\text{Ø}3-1/2$  in. ( $\text{Ø}90$  mm). When the pipe size of the gas side is less than  $\text{Ø}5/8$  in. ( $\text{Ø}16$  mm), the wall hole should be  $\text{Ø}2.5$  in. ( $\text{Ø}65$  mm).

1. Remove the screw that attaches the mounting plate to the back of the indoor unit.



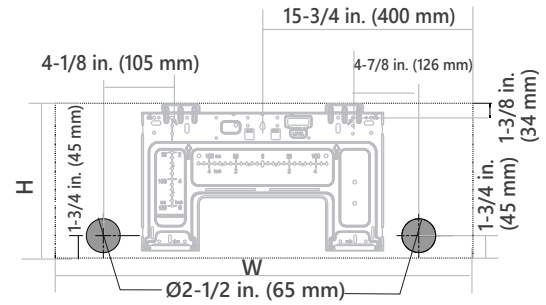
**Fig. 1-1: Remove the Mounting Bracket**

2. Secure the mounting plate to the wall with the screws provided. Make sure that the mounting plate is flat against the wall.

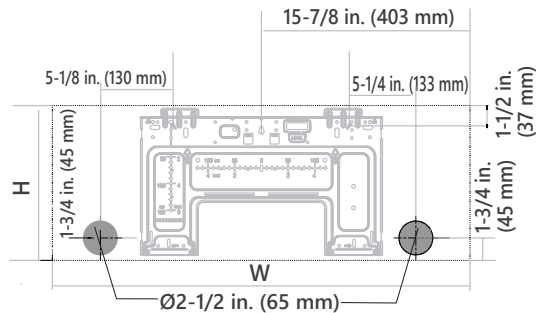


**Fig. 1-2: Install the Mounting Plate**

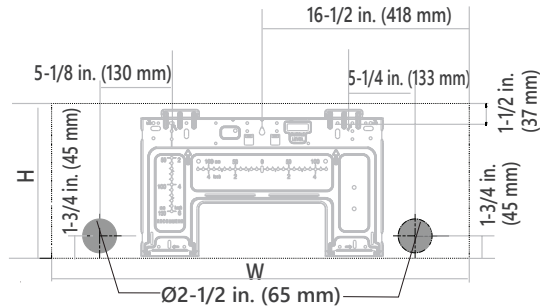
3. Confirm the mounting plate you own. Determine the location of the wall hole based on the position of the mounting plate. The dotted rectangular box on the right figure shows the size of your product.



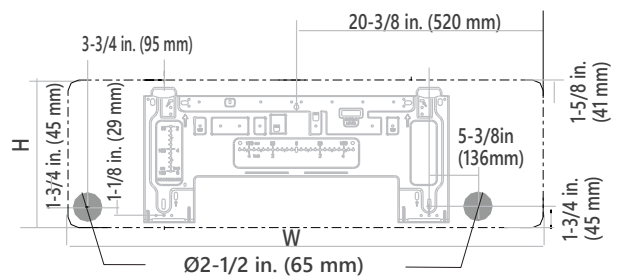
**Indoor unit dimensions (W x H):**  
28-3/4 in. (729 mm) x 11-1/2 in. (293 mm)



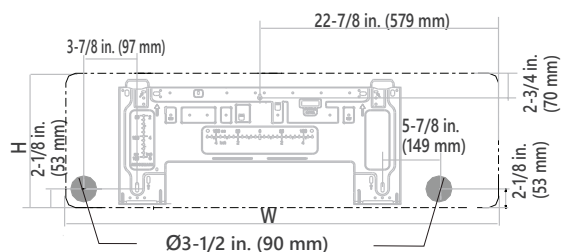
**Indoor unit dimensions (W x H):**  
31-3/4 in. (806 mm) x 11-5/8 in. (296 mm)



**Indoor unit dimensions (W x H):**  
32-7/8 in. (835 mm) x 11-5/8 in. (296 mm)



**Indoor unit dimensions (W x H):**  
38-1/4 in. (971 mm) x 12-5/8 in. (321 mm)



**Indoor unit dimensions (W x H):**  
42-5/8 in. (1082 mm) x 13-1/4 in. (338 mm)

**Fig. 1-3: Unit Dimensions**

## Step 2 - Drill Wall Hole

### ⚠ CAUTION

When drilling the wall hole, make sure to avoid wires, plumbing, and other sensitive components.

1. Using a 2-1/2 in. (65 mm) or 3-1/2 in. (90 mm) core drill (according to the unit you purchased), drill a hole in the wall. Make sure that the hole is drilled at a slight downward angle so that the outdoor end of the hole is lower than the indoor end by about 1/4 in. (5-7 mm). This will ensure proper water drainage.

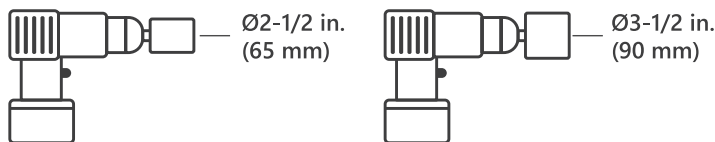


Fig. 2-1: Drill Core Sizes

2. Drill the wall hole

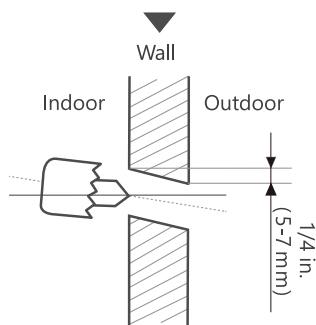


Fig. 2-2: Drill At Downward Angle

3. Place the protective wall cuff in the hole. This protects the edges of the hole and will help seal it when you finish the installation process.

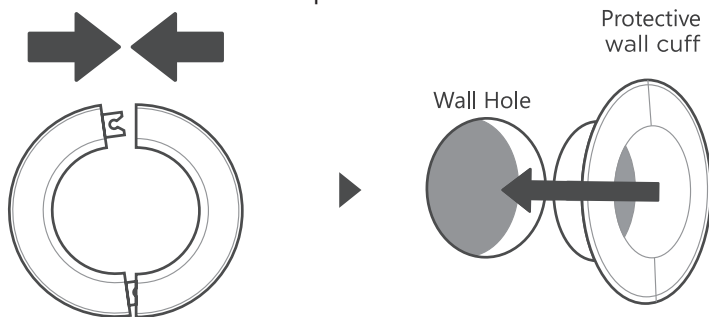


Fig. 2-3: Install the Protective Cuff

### NOTE

#### FOR CONCRETE OR BRICK WALLS

If the wall is made of brick, concrete, or similar material, drill 1/4 in.-diameter (5 mm-diameter) holes in the wall and insert the sleeve anchors provided. Then secure the mounting plate to the wall by tightening the screws directly into the clip anchors.

## Step 3 - Refrigerant Pipe & Drain Hose

### NOTE

The refrigerant piping is inside an insulating sleeve attached to the back of the unit. You must prepare the piping before passing it through the hole in the wall.

#### Prepare Refrigerant Piping

1. Based on the position of the wall hole relative to the mounting plate, choose the side from which the piping will exit the unit. You have four options for the exit direction of the piping.

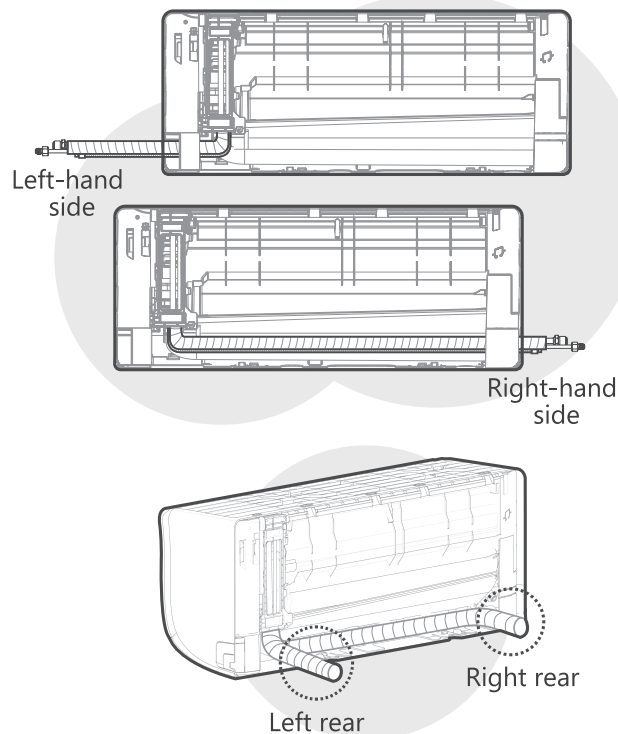


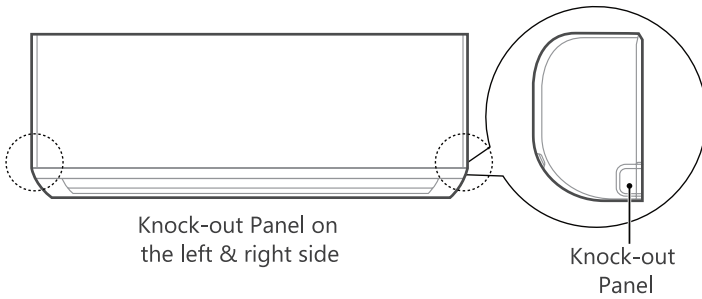
Fig. 3-1: Choose Exit Direction for Piping

2. If the wall hole is behind the unit, keep the knock-out panel in place. If the wall hole is to the side of the indoor unit, remove the plastic knock-out panel from that side of the unit. If the plastic panel is too difficult to remove by hand, use needle-nose pliers. See Fig. 3-2.

### ⚠ CAUTION

Be extremely careful not to dent or damage the piping while bending them away from the unit. Any dents in the piping will affect the unit's performance.

3. Connect the indoor unit's refrigerant piping to the connective piping that will join the indoor and outdoor units. Refer to the **Refrigerant Piping Connection** section of this manual for detailed instructions.



**Fig. 3-2: Knock-Out Panel Location**

**NOTE**

If existing connective piping is already embedded in the wall, proceed directly to the **Connect Drain Hose** step.

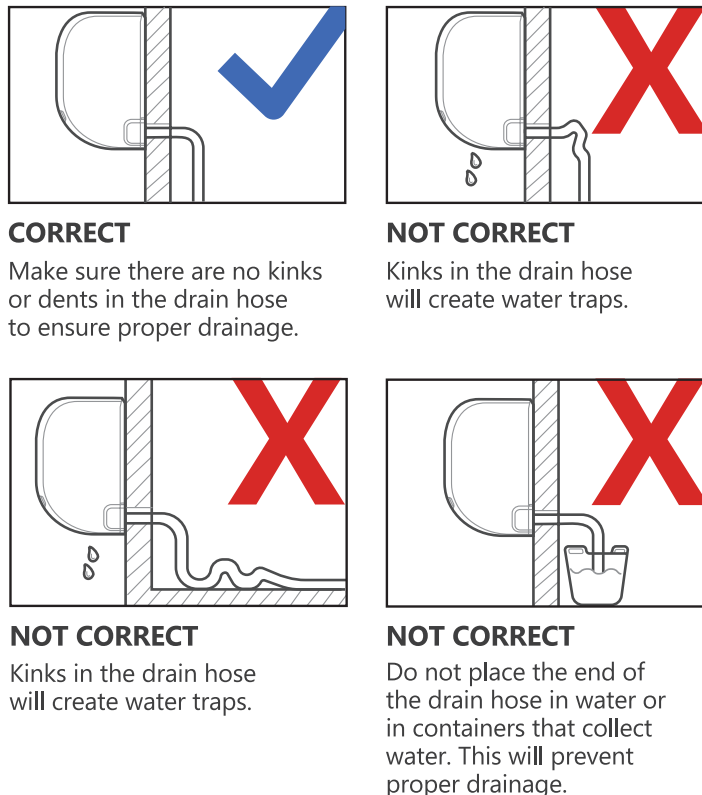
**Connect The Drain Hose**

1. The drain hose can be attached to the left or right side. To ensure proper drainage, attach the drain hose to the same side that your refrigerant piping exits the unit. Attach drain hose extension (purchased separately) to the end of the drain hose.
2. Wrap the connection point firmly with Teflon tape to ensure a good seal and to prevent leaks.
3. For the portion of the drain hose that will remain indoors, wrap it with foam pipe insulation to prevent condensation.
4. Remove the air filter and pour a small amount of water into the drain pan to make sure that water flows from the unit smoothly.

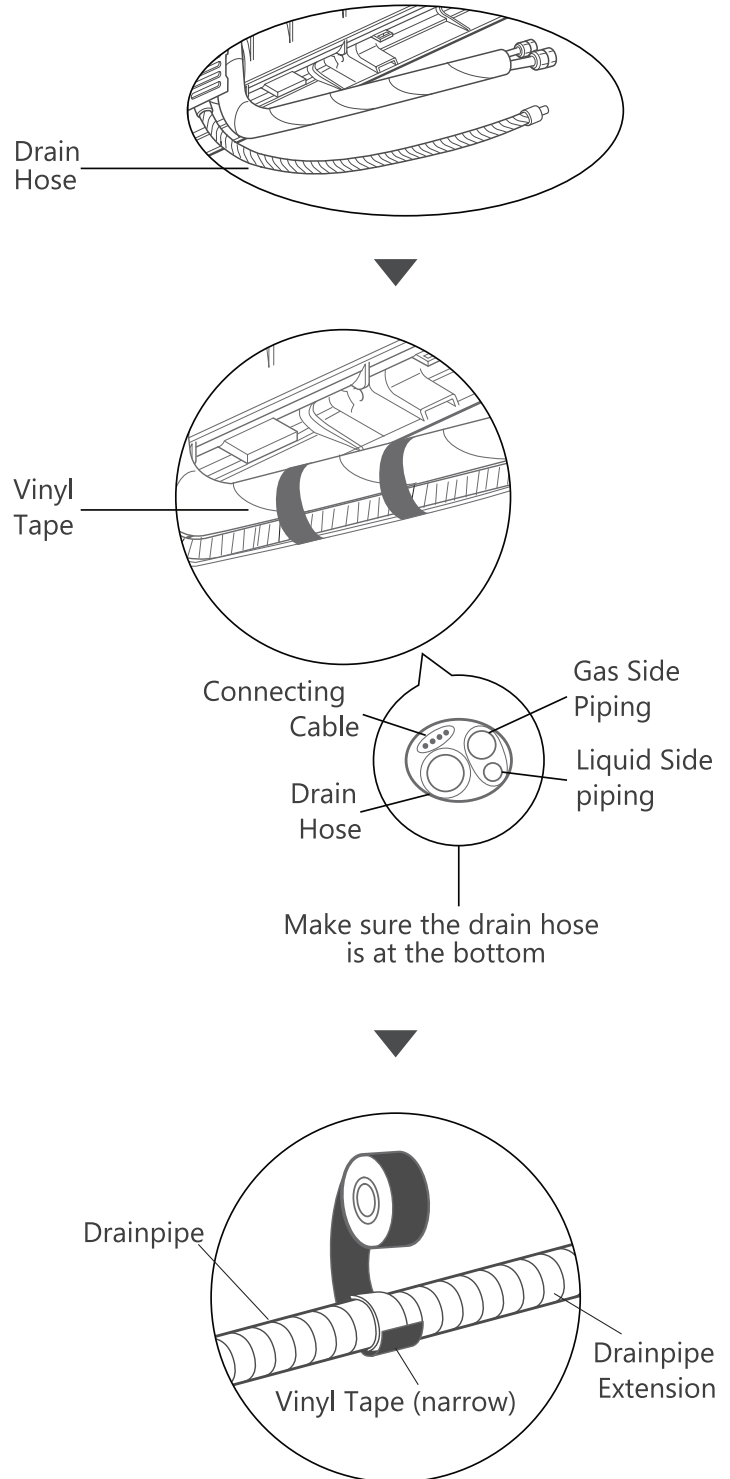
**NOTE**

**On Drain Hose Placement**

Make sure to arrange the drain hose according to the following figures.



**Fig. 3-3: Drain Hose Placement**

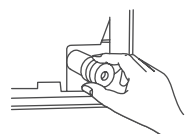


**Fig. 3-4: Drain Hose Routing**

**CAUTION**

**PLUG THE UNUSED DRAIN HOLE**

To prevent unwanted leaks, you must plug the unused drain hole with the rubber plug provided.



## Step 4 - Electrical work preparation

### **⚠ WARNING**

**BEFORE PERFORMING ANY ELECTRICAL WORK, READ THESE REGULATIONS**

**BEFORE PERFORMING ANY ELECTRICAL OR WIRING WORK, TURN OFF THE MAIN POWER TO THE SYSTEM.**

- All wiring must comply with local and national electrical codes and regulations and must be installed by a licensed electrician.
- All electrical connections must be made according to the Electrical Connection Diagram located on the panels of the indoor and outdoor units.
- If there is a serious safety issue with the power supply, stop work immediately. Explain your reasoning to the client and refuse to install the unit until the safety issue is properly resolved.
- If connecting power to fixed wiring, a surge protector and main power switch should be installed.
- Only connect the unit to an individual branch circuit outlet. Do not connect another appliance to that outlet.
- Make sure to properly ground the air conditioner.
- Every wire must be firmly connected. Loose wiring can cause the terminal to overheat, resulting in product malfunction and possible fire.
- Do not let wires touch or rest against refrigerant tubing, the compressor, or any moving parts within the unit.
- To avoid getting an electric shock, never touch the electrical components soon after the power supply has been turned off. After turning off the power, always wait 10 minutes or more before you touch the electrical components.

### **⚠ WARNING**

All wiring must be performed strictly following the wiring diagram located on the back of the Indoor Unit's front panel. Connect The Signal And Power Cables

The signal cable enables communication between the indoor and outdoor units. You must first choose the right cable size before preparing it for connection.

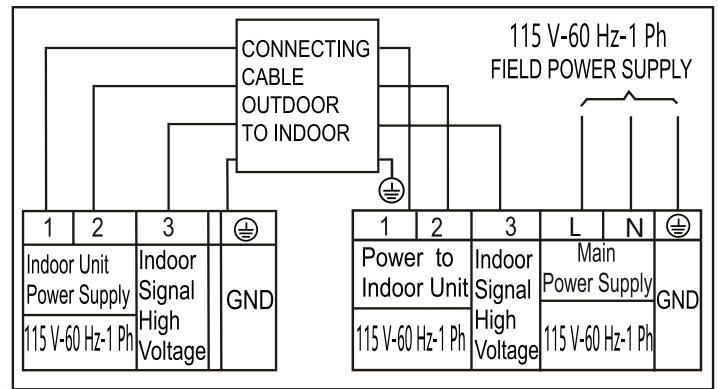
### **NOTE**

Choose the cable type according to the local electrical codes and regulations. Please choose the right cable size according to the Minimum Circuit Ampacity indicated on the nameplate of the unit.

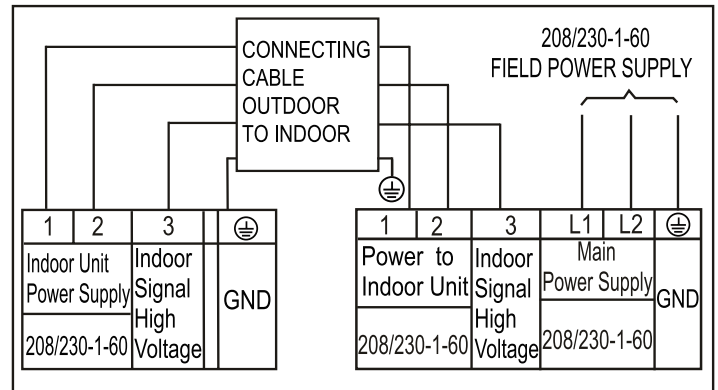
### **⚠ CAUTION**

#### **DO NOT MIX UP LIVE AND NULL WIRES**

This is dangerous and can cause the air conditioning unit to malfunction.



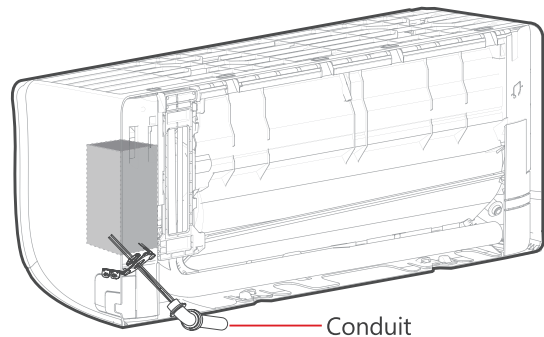
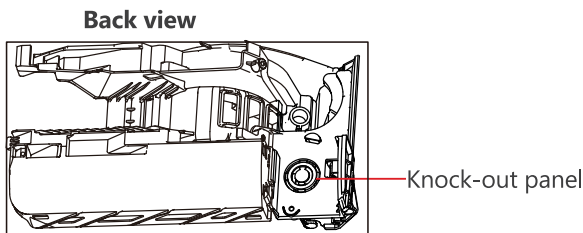
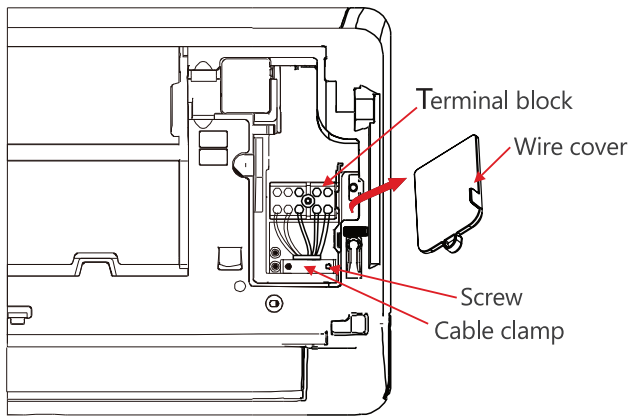
**Connection Diagram (115V)**



**Connection Diagram (208/230V)**

**Fig. 4-1: Wiring Diagrams**

1. Open and attach the position of the panel, then open the covers of the two lock blocks, remove the screw, then hold both sides of the lower panel in the place marked "PULL", pull it upwards to release the buckles, then take the lower panel down (please refer to Step 6 - Mount Indoor Unit).
2. Open the wire box cover on the right side of the unit. This will reveal the terminal block.
3. Unscrew the cable clamp below the terminal block and place it to the side.
4. Facing the back of the unit, remove the plastic panel on the bottom left-hand side.
5. Feed the signal wire through this slot, from the back of the unit to the front.
6. Facing the front of the unit, connect the wire according to the indoor unit's wiring diagram, connect the u-lug, and firmly screw each wire to its corresponding terminal.
7. After checking to make sure every connection is secure, use the cable clamp to fasten the signal cable to the unit. Screw the cable clamp down tightly.
8. Replace the wire cover on the front of the unit and the plastic panel on the back.

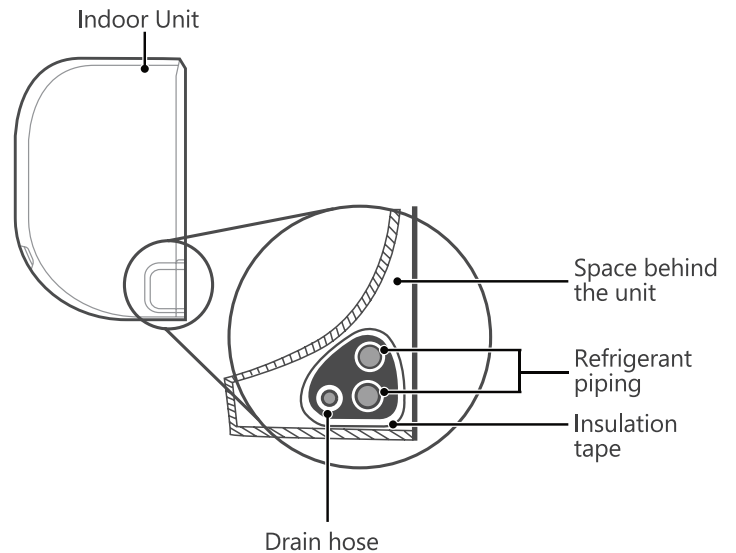


**Fig. 4-2: Wiring Routing**

## Step 5 - Wrap Piping & Cables

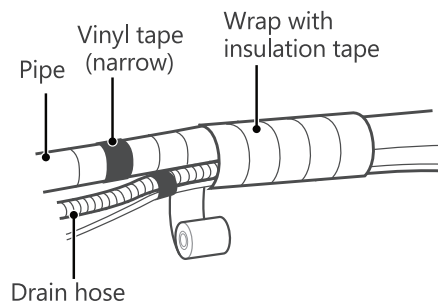
### NOTE

Before passing the piping, and drain hose through the wall hole, you must bundle them together to save space, protect them, and insulate them.



**Fig. 5-1: Bundle Arrangement**

1. Bundle the drain hose, and refrigerant pipes as shown in Fig. 5-1.



**Fig. 5-2: Wrap The Bundle With Vinyl Tape**

2. Using adhesive vinyl tape, attach the drain hose to the underside of the refrigerant pipes
3. Using insulation tape, wrap the refrigerant pipes and the drain hose tightly together. Double-check that all items are bundled.

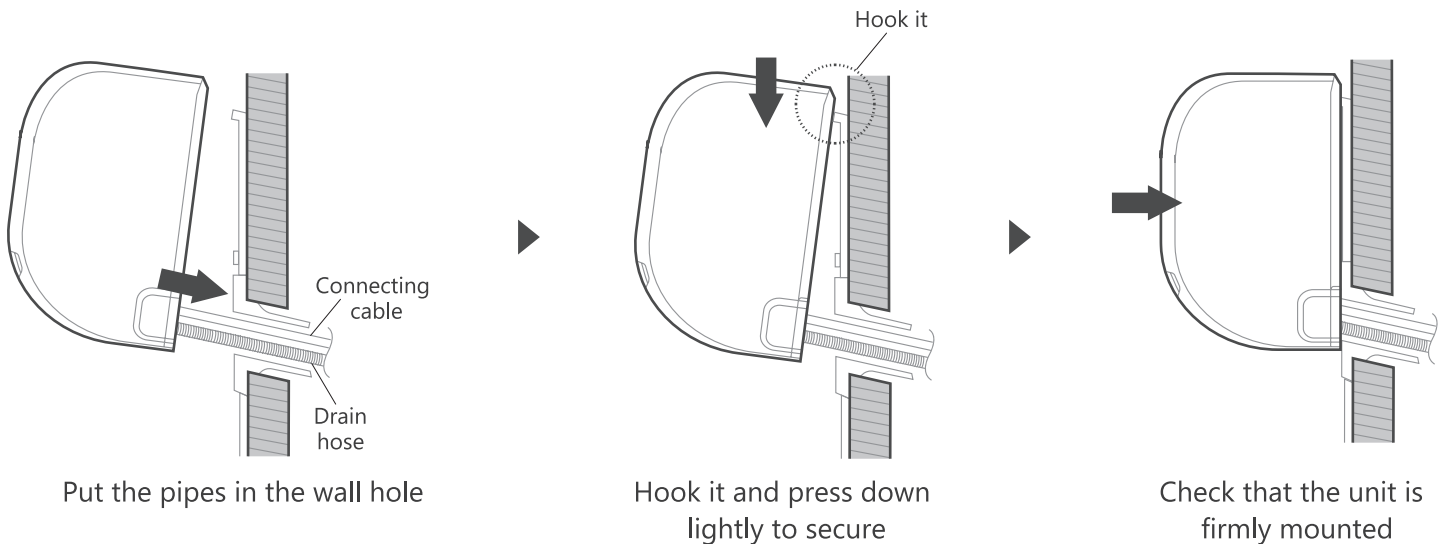
### **DRAIN HOSE MUST BE ON BOTTOM**

Make sure that the drain hose is at the bottom of the bundle. Putting the drain hose at the top of the bundle can cause the drain pan to overflow, which can lead to fire or water damage.

### **DO NOT WRAP ENDS OF PIPING**

When wrapping the bundle, keep the ends of the piping unwrapped. You need to access them to test for leaks at the end of the installation process (refer to the Electrical Checks and Leak Checks section of this manual).

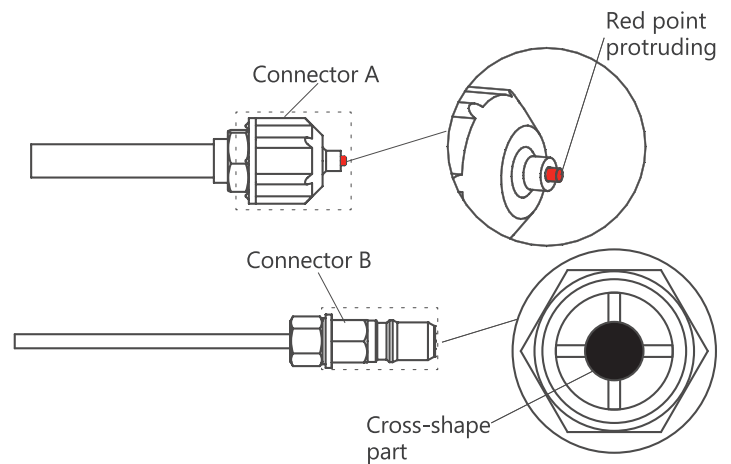
## Step 6 - Mount Indoor Unit



**Fig. 6-1: Mount the Unit to the Wall Bracket**

If you installed new connective piping to the outdoor unit, do the following:

1. If you have already passed the refrigerant piping through the hole in the wall, proceed to number 4.
2. Otherwise, double-check that the ends of the refrigerant pipes are sealed to prevent dirt or foreign materials from entering the pipes.
3. Slowly pass the wrapped bundle of refrigerant pipes, drain hose, and signal wire through the hole in the wall.
4. Hook the top of the indoor unit on the upper hook of the mounting plate.
5. Check that the unit is hooked firmly on mounting by applying slight pressure to the left and right-hand sides of the unit. The unit should not jiggle or shift.
6. Using even pressure, push down on the bottom half of the unit. Keep pushing down until the unit snaps onto the hooks along the bottom of the mounting plate.
7. Again, check that the unit is firmly mounted by applying slight pressure to the left and the right-hand sides of the unit.



**Fig. 6-2: A-B Pipe Connection**

1. Keep pressing the cross-shape part of connector B with a tool for about 5~10 seconds until the red protruding point of connector A retracts completely.
2. Remove connectors A and B, then perform the refrigerant piping connection between the indoor unit and the outdoor unit.

### **CAUTION**

For the units that adopt the following pipe connectors, please strictly perform the piping work in accordance with the following instructions.

- Before performing the refrigerant piping connection, always wear work gloves and goggles, and remember that the connectors A and B are not allowed to face people directly.

**This Page Is Left Blank Intentionally**

# Install Your Outdoor Unit

## Table of Contents

Step 1 - Installation Location.....	31
Fig. 1-1: Clearance Dimensions.....	31
Fig. 1-2: High Wind Installation.....	31
Step 2 - Install Drain Joint .....	32
Fig. 2-1: Drain Hole Location.....	32
Fig. 2-2: Installation of the Drain Joint.....	32
Step 3 - Anchor The Outdoor Unit.....	33
Fig. 3-1: Unit Dimensions .....	33
Table 3-1: Outdoor Unit Dimensions .....	33
Step 4 - Refrigerant Piping Connections .....	34
Table 4-1: Maximum Length & Drop Height .....	34
Fig. 4-1: Oil Trap Arrangement.....	34
Fig. 4-2: Correct Pipe Cutting.....	34
Fig. 4-3: Reamer Tool.....	35
Fig. 4-4: Copper pipe and flare nut.....	35
Fig. 4-5: Flaring Tool .....	35
Fig. 4-6: Flare Form .....	35
Fig. 4-7: Flare Shape .....	35
Table 4-2: Flare Dimensions/Tightening Torque.....	35
Fig. 4-8: Align the center of the two pipes .....	36
Fig. 4-9: Spanner and Backup Wrench .....	36
Fig. 4-10: Bend the Tubing.....	36
Fig. 4-11: Remove the Valve Cover .....	36
Fig. 4-12: Connect to the Valves .....	36
Fig. 4-13: All Pipes Connected.....	37
Step 5 - Connect Signal & Power Cables.....	37
Fig. 5-1: Power Wiring.....	37
Fig. 5-2: Remove Electrical Cover .....	37
Fig. 5-3: Prepare Wire Ends.....	38
Fig. 5-4: Attach Wires To Terminal Plate.....	38
Step 6 - Air Evacuation .....	38
Fig. 6-1: Manifold Gauge Arrangement.....	38
Fig. 6-2: Service Valve.....	39
Table 6-1: Additional Refrigerant Formula.....	39
Step 7 - Electrical & Gas Leak Checks.....	39
Fig. 7-1: Indoor and Outdoor Checkpoints.....	40
Step 8 - Test Run .....	40
Table 8-1: Test Run Check List.....	40
Fig. 8-1: Manual Control Button Location.....	41
Trademarks Copyrights & Legal Statement.....	41
Disposal and Recycling.....	41
Data Protection Notice .....	41

# Step 1 - Installation Location

## NOTE

### BEFORE INSTALLATION

Before installing the outdoor unit, you must choose an appropriate location. The following are standards that will help you choose an appropriate location for the unit.

**Proper installation locations must meet the following standards:**

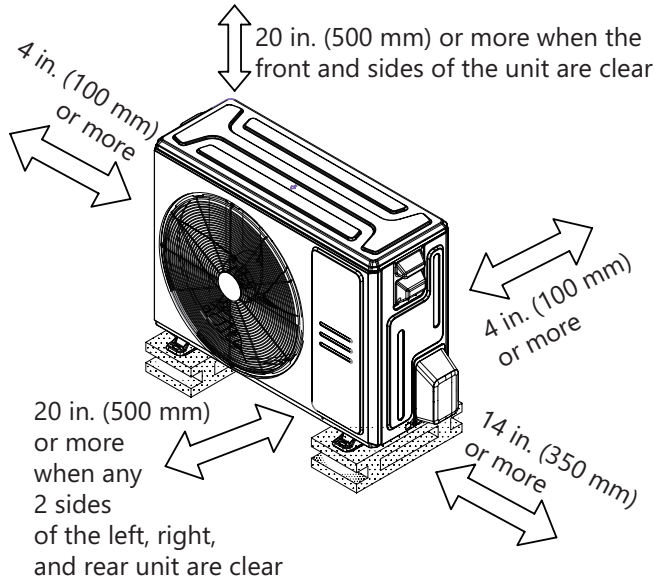
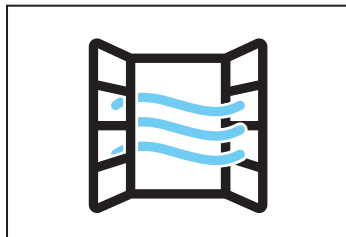


Fig. 1-1: Clearance Dimensions



- Good air circulation and ventilation.

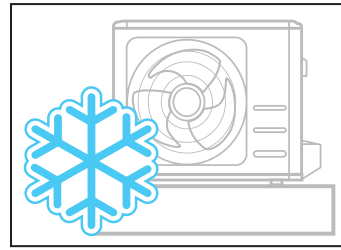
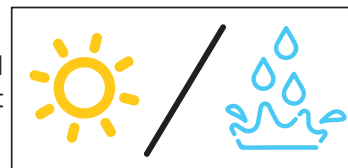
- Firm and solid - the location can support the unit and will not vibrate.



- Noise from the unit will not disturb other people.



- Protected from prolonged periods of direct sunlight or rain.



- Where snowfall is anticipated, take appropriate measures to prevent ice buildup and coil damage.

## CAUTION

### SPECIAL CONSIDERATIONS FOR EXTREME WEATHER

#### If the unit is exposed to heavy wind:

Install the unit so that the air outlet fan is at a 90° angle to the direction of the wind. If needed, build a barrier in front of the unit to protect it from extremely heavy winds. See Fig. 1-2.

#### If the unit is frequently exposed to heavy rain or snow:

Build a shelter above the unit to protect it from the rain or snow. Be careful not to obstruct airflow around the unit.

#### If the unit is frequently exposed to salty air (seaside):

Use an outdoor unit that is specially designed to resist corrosion.

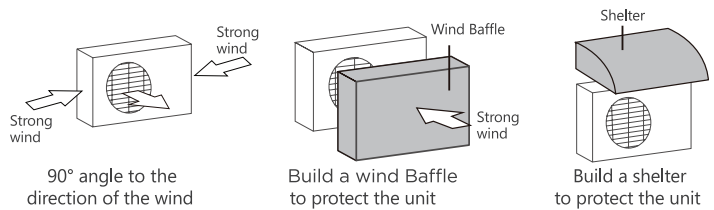
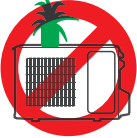




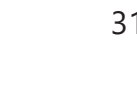


Fig. 1-2: High Wind Installation

### DO NOT install the unit in the following locations:

- Near an obstacle that will block air inlets and outlets. 
- Near animals or plants that will be harmed by hot air discharge. 
- Near a public street, crowded areas, or where noise from the unit will disturb others. 
- Near any source of combustible gas. 
- In a location that is exposed to large amounts of dust. 
- In a location exposed to excessive amounts of salty air. 

### Unpacking The Unit:

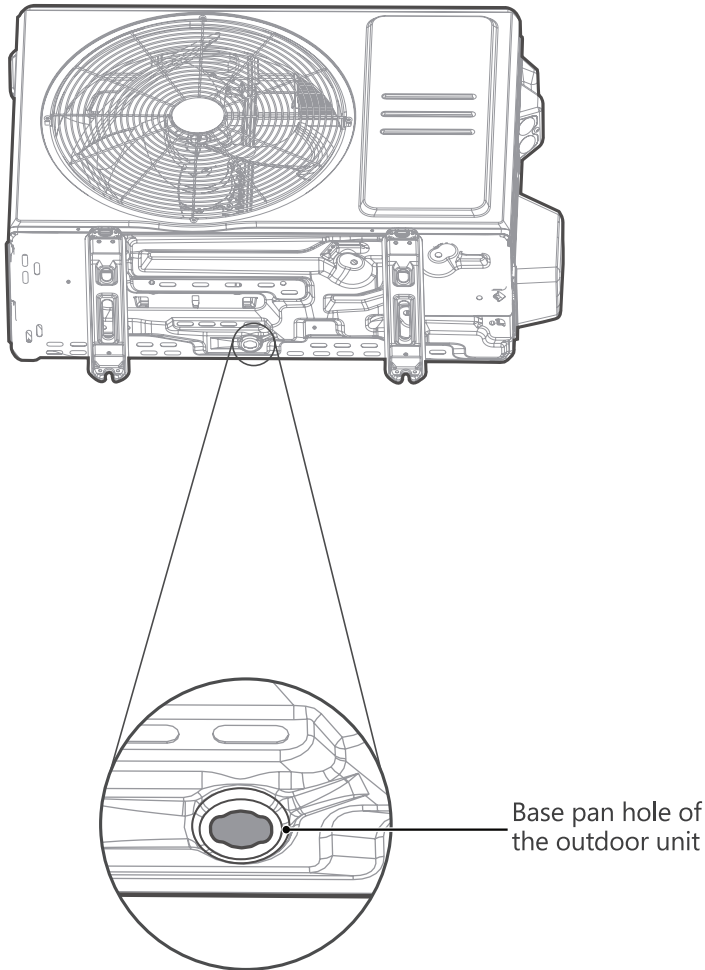
1. Cut the packing belt.
2. Take the unit out of the carton.
3. Remove the foam from the unit.
4. Remove the packaging bag from the unit.

## Step 2 - Install Drain Joint

### NOTE

#### PRIOR TO INSTALLATION

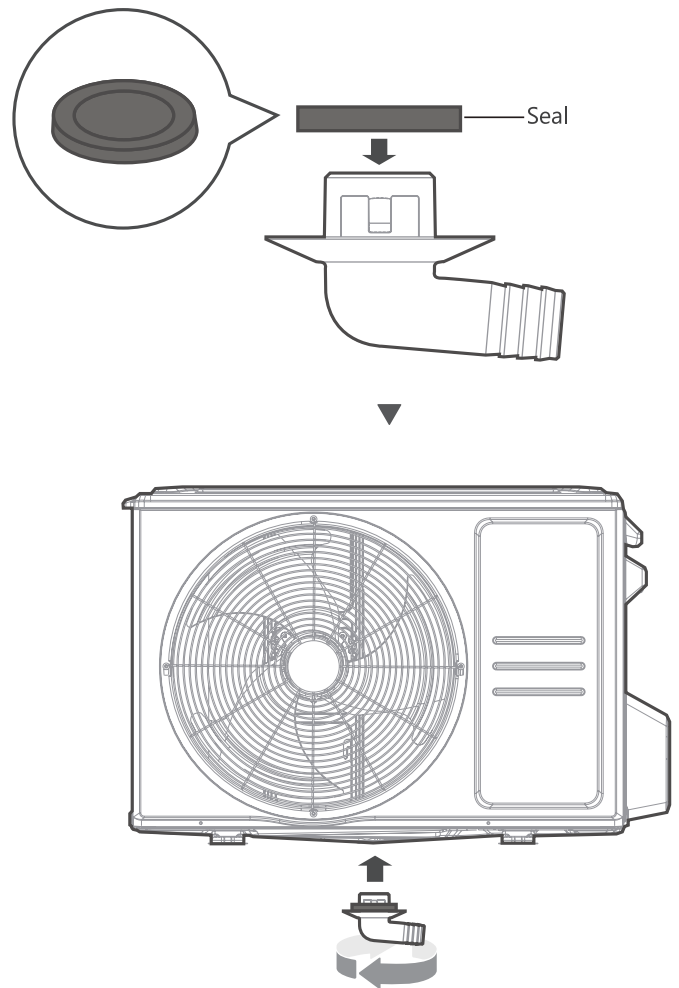
Before bolting the outdoor unit in place, you must install the drain joint at the bottom of the unit. For the units with base pan built-in with multiple holes for proper draining during defrost, the drain joint does not need to be installed.



**Fig. 2-1: Drain Hole Location**

1. Find the base pan hole on the outdoor unit.

2. Fit the rubber seal on the end of the drain joint that will connect to the outdoor unit.



**Fig. 2-2: Installation of the Drain Joint**

3. Insert the drain joint into the hole in the base pan of the unit. The drain joint will click in place.
4. Connect a drain hose extension (not included) to the drain joint to redirect water from the unit during heating mode.

### NOTE

#### IN COLD CLIMATES

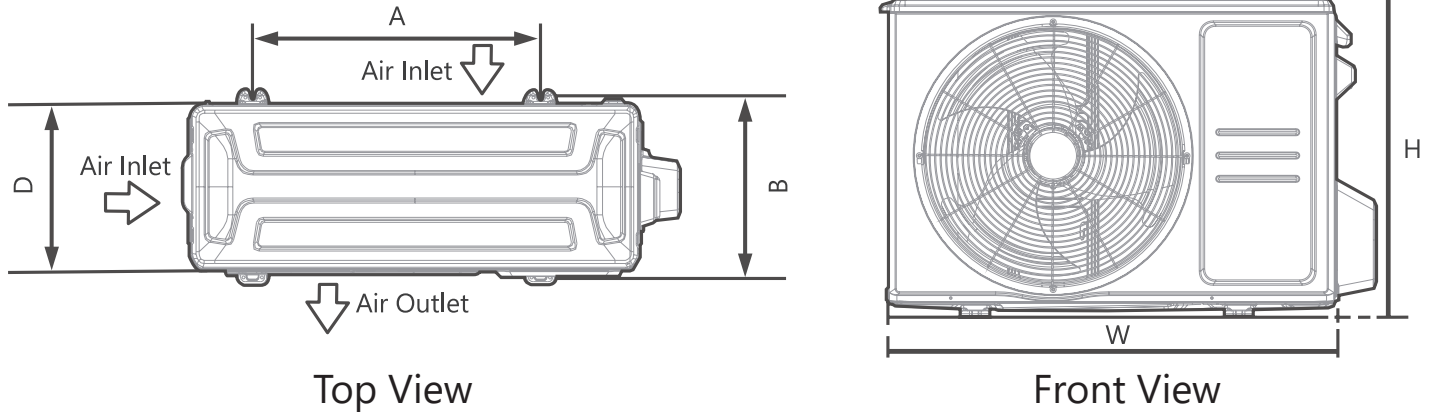
In cold climates, make sure that the drain hose is as vertical as possible to ensure swift water drainage. If water drains too slowly, it can freeze in the hose and flood the unit.

## Step 3 - Anchor The Outdoor Unit

### **⚠ WARNING**

**WHEN DRILLING INTO CONCRETE, EYE PROTECTION IS RECOMMENDED AT ALL TIME.**

- The outdoor unit can be anchored to the ground or to a wall-mounted bracket with bolt(M10). Prepare the installation base of the unit according to the dimensions in Table 3-1.
- The following is a list of different outdoor unit sizes and the distance between their mounting feet. Prepare the installation base of the unit according to the dimensions in Table 3-1.



**Fig. 3-1: Unit Dimensions**

**Table 3-1: Outdoor Unit Dimensions**

Outdoor Unit Dimensions W x H x D	Mounting Dimensions	
	Distance A	Distance B
30-1/8 in. x 21-7/8 in. x 11-7/8 in. (765 mm x 555 mm x 303 mm)	17- 7/8 in. (452 mm)	11-1/4 in. (286 mm)
31-3/4 in. x 21-7/8 in. x 12-7/8 in. (805 mm x 554 mm x 330 mm)	20-1/8 in. (511 mm)	12-1/2 in. (317 mm)
35 in. x 26-1/4 in. x 13-1/2 in. (890 mm x 673 mm x 342 mm)	26-1/8 in. (663 mm)	13-7/8 in. (354 mm)
37-1/4 in. x 31-7/8 in. x 16-1/8 in. (946 mm x 810 mm x 410 mm)	26-1/2 in. (673 mm)	15-7/8 in. (403 mm)

**If you install the unit on the ground or a concrete mounting platform, do the following:**

1. Mark the positions for four expansion bolts based on the dimensions chart.
2. Pre-drill holes for expansion bolts.
3. Place a nut on the end of each expansion bolt.
4. Hammer expansion bolts into the pre-drilled holes.
5. Remove the nuts from the expansion bolts and place the outdoor unit on the bolts.
6. Put the washer on each expansion bolt, then replace the nuts.
7. Using a wrench, tighten each nut until it is snug.

**If you install the unit on a wall-mounted bracket, do the following:**

1. Mark the position of bracket holes based on the dimensions chart.
2. Pre-drill the holes for the expansion bolts.
3. Place a washer and nut on the end of each expansion bolt.
4. Thread expansion bolts through holes in mounting brackets, put mounting brackets in position, and hammer expansion bolts into the wall.
5. Check that the mounting brackets are level.
6. Carefully lift the unit and place its mounting feet on brackets.
7. Bolt the unit firmly onto the brackets.
8. If allowed, install the unit with rubber gaskets to reduce vibrations and noise.

### **⚠ CAUTION**

**Make sure that the wall is made of solid brick, concrete, or similarly strong material. The wall must be able to support at least four times the weight of the unit.**

# Step 4 - Refrigerant Piping Connections

## ⚠ WARNING

WHEN CONNECTING REFRIGERANT PIPING, DO NOT LET SUBSTANCES OR GASES OTHER THAN THE SPECIFIED REFRIGERANT ENTER THE UNIT. THE PRESENCE OF OTHER GASES OR SUBSTANCES WILL LOWER THE UNIT'S CAPACITY, AND CAN CAUSE ABNORMALLY HIGH PRESSURE IN THE REFRIGERATION CYCLE. THIS CAN CAUSE EXPLOSION AND INJURY.

All field piping must be completed by a licensed technician and must comply with local and national regulations.

**Table 4-1: Maximum Length & Drop Height**

Model	Length of Piping	Maximum Drop Height
6K/9K/12K	82 ft. (25 m)	49 ft. 3/16 in. (15 m)
18K	98 ft. 7/19 in. (30 m)	65 ft. 5/8 in. (20 m)
24K/30K/33K	164 ft. (50 m)	82 ft. (25 m)
36K	213 ft. (65 m)	98 ft. 7/19 in. (30 m)

### NOTE ON PIPE LENGTH

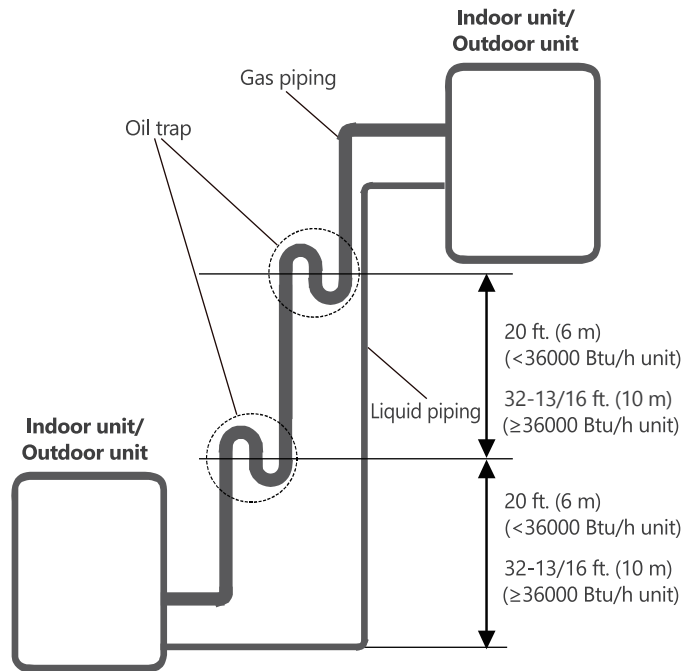
The length of refrigerant piping will affect the performance and energy efficiency of the unit. Nominal efficiency is tested on units with a pipe length of 2 ft. (7.5 m). A minimum pipe run of 9 ft. 7/8 in. (3 m) is required to minimize vibration and excessive noise.

## ⚠ CAUTION

### Oil traps

If oil flows back into the outdoor unit's compressor, this might cause liquid compression or deterioration of oil return. Oil traps in the rising gas piping can prevent this from happening.

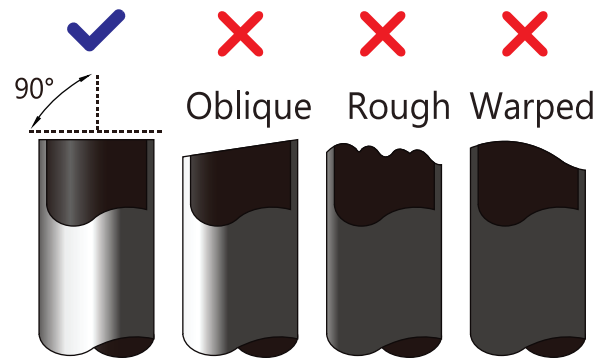
An oil trap should be installed every 20 ft. (6 m) of the vertical suction line riser (for units with a capacity of less than 36,000 Btu/h). An oil trap should be installed every 32-13/16 ft. (10 m) of vertical suction line riser (≥36000 Btu/h unit).



**Fig. 4-1: Oil Trap Arrangement Connection Instructions – Refrigerant Piping Cut pipes**

When preparing refrigerant pipes, take extra care to cut and flare them properly. This will ensure efficient operation and minimize the need for future maintenance.

1. Measure the distance between the indoor and outdoor units.
2. Using a pipe cutter, cut the pipe a little longer than the measured distance.
3. Make sure the pipe is cut at a perfect 90° angle.



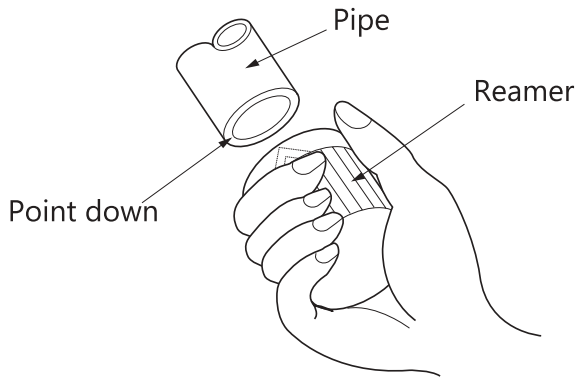
**Fig. 4-2: Correct Pipe Cutting**

### DO NOT DEFORM THE PIPE WHILE CUTTING

Be extra careful not to damage, dent, or deform the pipe while cutting. This will drastically reduce the heating efficiency of the unit.

## ⚠ CAUTION

**CHECK OVER THE END OF THE PIPE FOR CRACKS AND EVEN FLARING. ENSURE THE PIPE IS SEALED.**

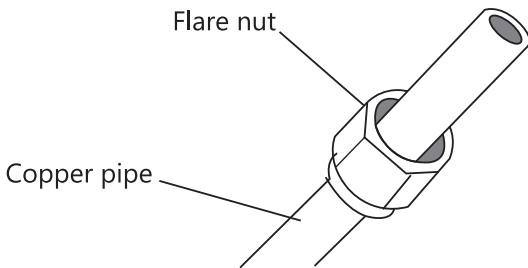


**Fig. 4-3: Reamer Tool**

**4. Remove the Burrs**

Burrs can affect the air-tight seal of the refrigerant piping connection. Therefore, they must be completely removed. To remove:

- a. Hold the pipe at a downward angle to prevent burrs from falling into the pipe.
- b. Using a reamer or deburring tool, remove all burrs from the cut section of the pipe

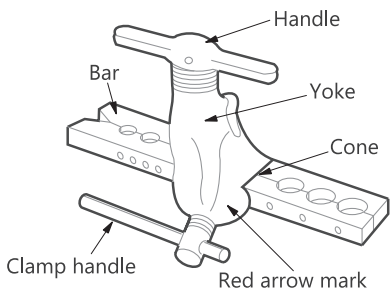


**Fig. 4-4: Copper pipe and flare nut**

**5. Flare the Pipe Ends.**

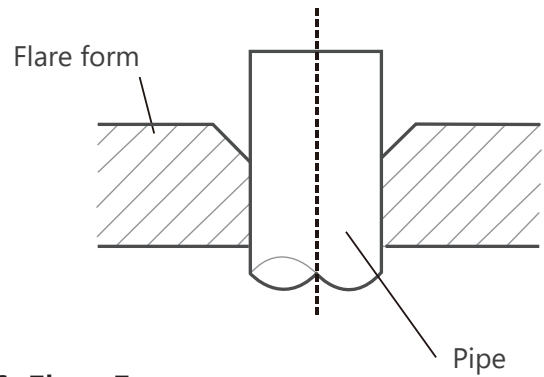
Proper flaring is essential to achieving an airtight seal.

- a. After removing the burrs from the cut pipe, seal the ends with PVC tape to prevent foreign materials from entering the pipe.
- b. Sheath the pipe with insulating material.
- c. Place the factory flare nut on the pipe facing the proper direction. Make sure they are facing the right direction. Once the ends are flared, it is impossible to put them on or change their direction.



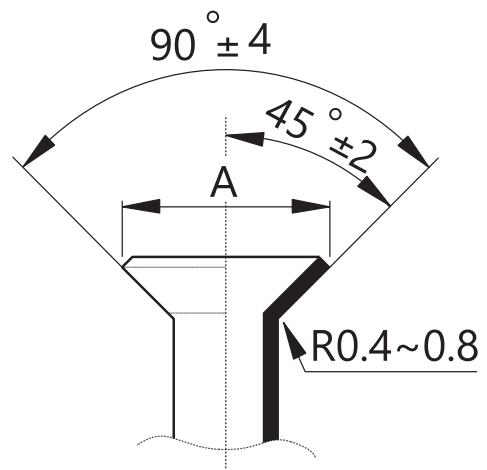
**Fig. 4-5: Flaring Tool**

- d. Remove the PVC tape from the ends of the pipe when ready to perform the flaring work.
- e. Clamp the flare block on the end of the pipe. The end of the pipe must extend beyond the flare form.



**Fig. 4-6: Flare Form**

- f. Place the flaring tool onto the form.
- g. Turn the handle of the flaring tool clockwise until the pipe is fully flared. Flare the pipe following the dimensions in Table 4-2.



**Fig. 4-7: Flare Shape**

**Table 4-2: Flare Dimensions/Tightening Torque**

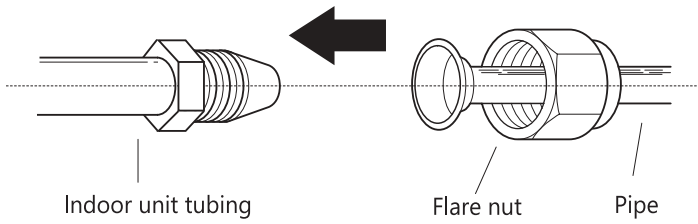
Pipe Size Outside Diameter	Flare Dimension (A)
in. (mm)	in. (mm)
Ø1/4 (6.35)	21/64 - 11/32 (8.4~8.7)
Ø3/8 (9.52)	33/64 - 17/32 (13.2~13.5)
Ø1/2 (12.7)	41/64 - 21/32 (16.2~16.5)
Ø5/8 (15.88)	49/64 - 25/32 (19.2~19.7)
Ø3/4 (19.05)	29/32 - 15/16 (23.2~23.7)

**Tightening Torque for Flare Nuts**

Pipe Size Outside Diameter	Tightening Torque
in. (mm)	ft. - lbs.
Ø1/4 (6.35)	13.0 - 18.0
Ø3/8 (9.52)	24.6 - 30.4
Ø1/2 (12.7)	39.8 - 47.7
Ø5/8 (15.88)	45.4 - 59.3
Ø3/4 (19.05)	7.15 - 87.5

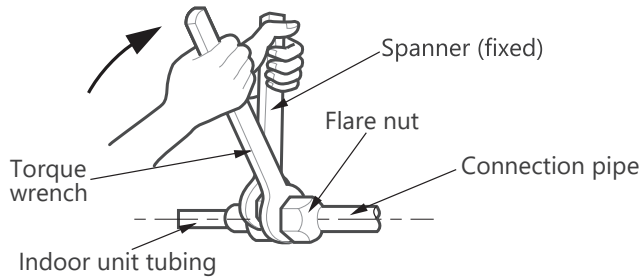
- h. Remove the flaring tool and flare block, then inspect the end of the pipe for cracks and even flaring.
6. Connect the Pipes  
Connect the copper pipes to the indoor unit first, then connect the pipes to the outdoor unit. Connect the low-

pressure pipe first, then connect the high-pressure pipe.  
a. Align the center of the two pipes that you will connect.



**Fig. 4-8: Align the center of the two pipes**

- b. Tighten the flare nut as much as possible by hand.
- c. Using a wrench, grip the nut on the unit tubing.
- d. While firmly gripping the nut, use a torque wrench to tighten the flare nut according to the torque values listed in Table 4-2.



**Fig. 4-9: Spanner and Backup Wrench**

All tubing bends should be performed with a properly sized tubing bender to prevent kinking or damaging the tubing.

- e. While firmly gripping the nut, use a torque wrench to tighten the flare nut according to the torque values listed in Table 4-2.

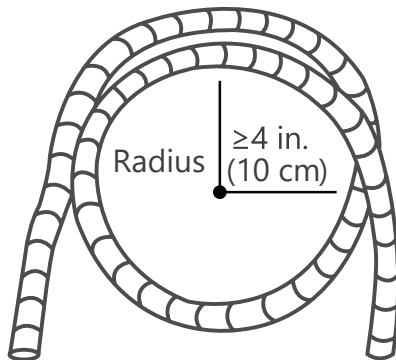
Ensure to wrap insulation around the piping. Direct contact with the bare piping may result in burns or frostbite.

- Make sure the pipe is properly connected.
- Over-tightening may damage the bell mouth and under-tightening may lead to leakage.

**NOTE**

**MINIMUM BEND RADIUS**

Carefully bend the tubing in the middle according to the diagram below. DO NOT bend the tubing over 90° or more than 3 times. Use care when bending pipe, do not kink pipe.



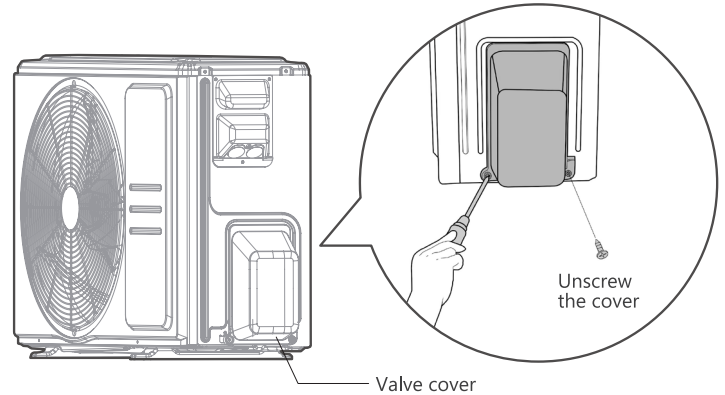
**Fig. 4-10: Bend the Tubing**

**Connecting Piping to Outdoor Unit**

**NOTE**

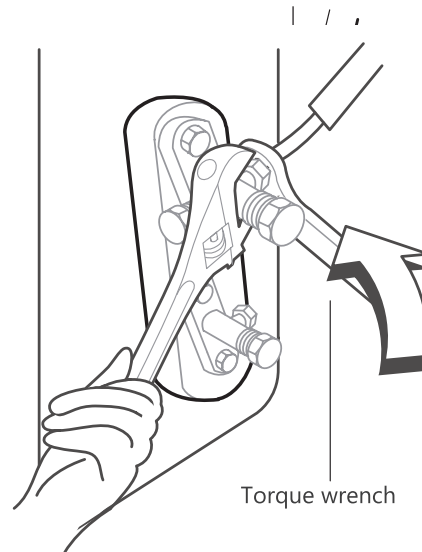
This section needs to use the torque requirements in Table 4-2.

1. Unscrew the cover from the packed valve on the side of the outdoor unit.



**Fig. 4-11: Remove the Valve Cover**

2. Remove protective caps from the ends of valves.
3. Align the flared pipe end with each valve and tighten the flare nut as tightly as possible by hand.
4. Using a spanner, grip the body of the valve. Do not grip the nut that seals the service valve.



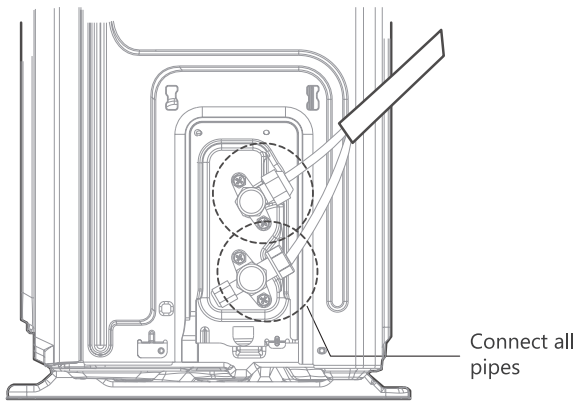
**Fig. 4-12: Connect to the Valves**

**WARNING**

**USE A SPANNER TO GRIP THE MAIN BODY OF VALVE**

Torque from tightening the flare nut can snap off other parts of the valve.

5. While firmly gripping the body of the valve, use a torque wrench to tighten the flare nut according to the correct torque values.
6. Loosen the flaring nut slightly, then tighten again.



**Fig. 4-13: All Pipes Connected**

7. Repeat the previous steps for the remaining pipe.

## Step 5 - Connect Signal & Power Cables

### **⚠ WARNING**

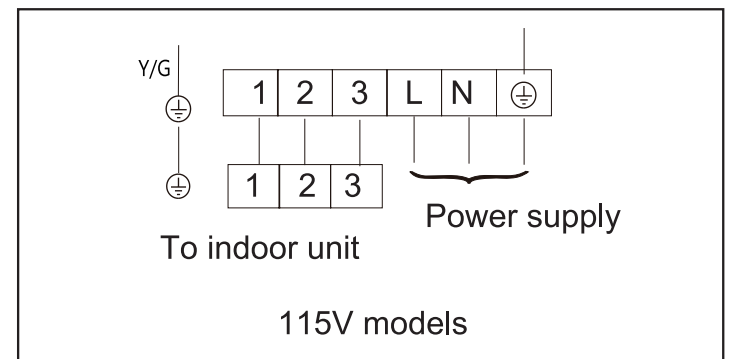
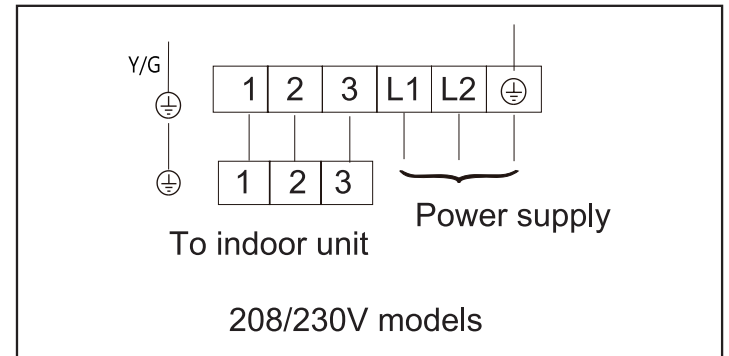
**BEFORE PERFORMING ANY ELECTRICAL WORK, READ THESE WARNINGS.**

- All wiring must comply with local and national electrical codes and regulations and must be installed by a licensed electrician.
- All electrical connections must be made according to the Electrical Connection Diagram located on the panels of the indoor and outdoor units.
- If there is a serious safety issue with the power supply, stop work immediately. Explain your reasoning to the client, and refuse to install the unit until the safety issue is properly resolved.
- Power voltage should be within 90-110% of rated voltage. Insufficient power supply can cause malfunction, electrical shock, or fire.
- Installation of an external surge suppressor at the outdoor disconnect is recommended.
- Power must be connected, a switch or circuit breaker that disconnects all poles and has a contact separation of at least 1/8 in. (3 mm) must be incorporated into the fixed wiring. The qualified technician must use an approved circuit breaker or switch.
- Only connect the unit to an individual branch circuit. Do not connect another appliance to that circuit.
- Make sure to properly ground the air conditioner.
- Every wire must be firmly connected. Loose wiring can cause the terminal to overheat, resulting in product malfunction and possible fire.
- Do not let wires touch or rest against refrigerant tubing, the compressor, or any moving parts within the unit.
- To avoid getting an electric shock, never touch the electrical components soon after the power supply has been turned off. After turning off the power, always wait 10 minutes or more before you touch the electrical components.
- Make sure that you do not cross your electrical wiring

with your signal wiring. This may cause distortion, interference or possibly damage to circuit boards.

### **⚠ WARNING**

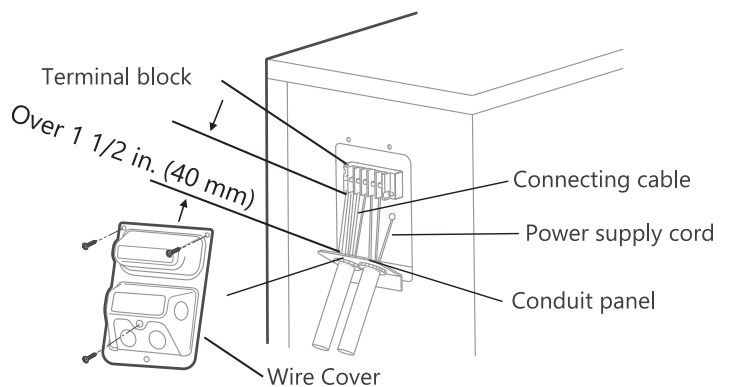
**BEFORE PERFORMING ANY ELECTRICAL OR WIRING WORK, TURN OFF THE MAIN POWER TO THE SYSTEM.**



**Fig. 5-1: Power Wiring**

The outside unit's terminal block is protected by an electrical wiring cover on the side of the unit. A comprehensive wiring diagram is printed on the inside of the wiring cover.

1. Remove the wire cover from the unit by loosening the 3 screws.



Please select the appropriate through-hole according to the diameter of the wire.

**Fig. 5-2: Remove Electrical Cover**

2. Dismount caps on the conduit panel.
3. Temporarily mount the conduit tubes (not included) on the conduit panel.
4. Properly connect both the power supply and low-voltage lines to the corresponding terminals on the

terminal block.

5. Ground the unit in accordance with local codes.
6. Be sure to size each wire, allowing several inches longer than the required length for wiring.
7. Use lock nuts to secure the conduit tubes.

### How to properly connect the wire lines.

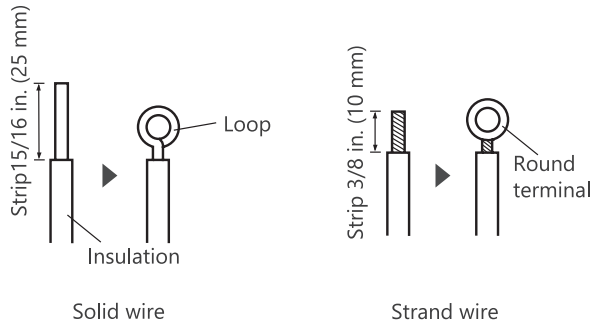


Fig. 5-3: Prepare Wire Ends

1. Strip the wire ends and attach the correct terminal ends.

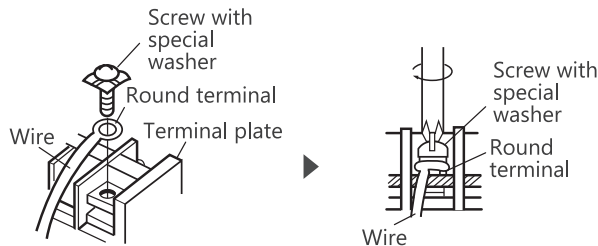


Fig. 5-4: Attach Wires To Terminal Plate

2. Connect the line to the corresponding terminals on the terminal block.

## Step 6 - Air Evacuation

### NOTE

When opening valve stems, turn the hexagonal wrench until it hits the stopper. Do not try to force the valve to open further.

Open valves slowly until you hear refrigerant, and allow pressure to equalize before opening fully. Open the large vapor line valve first.

### PREPARATIONS AND PRECAUTIONS

Air and foreign matter in the refrigerant circuit can cause abnormal rises in pressure, which can damage the air conditioner, reduce its efficiency, and cause injury. Use a vacuum pump and manifold gauge to evacuate the refrigerant circuit, removing any non-condensable gas and moisture from the system. Evacuation should be performed upon initial installation and when the unit is relocated.

### CAUTION

### BEFORE PERFORMING EVACUATION

- Check to make sure the connective pipes between the indoor and outdoor units are connected properly.
- Check to make sure all wiring is connected properly.

### Evacuation Instructions

1. Connect the charge hose of the manifold gauge to the service port on the outdoor unit's low pressure

valve.

2. Connect another charge hose from the manifold gauge to the vacuum pump.
3. Open the Low-Pressure side of the manifold gauge. Keep the High-Pressure side closed.
4. Tighten refrigerant valve caps hand-tight plus flat to ensure there are no vacuum leaks.
5. Turn on the vacuum pump to evacuate the system.

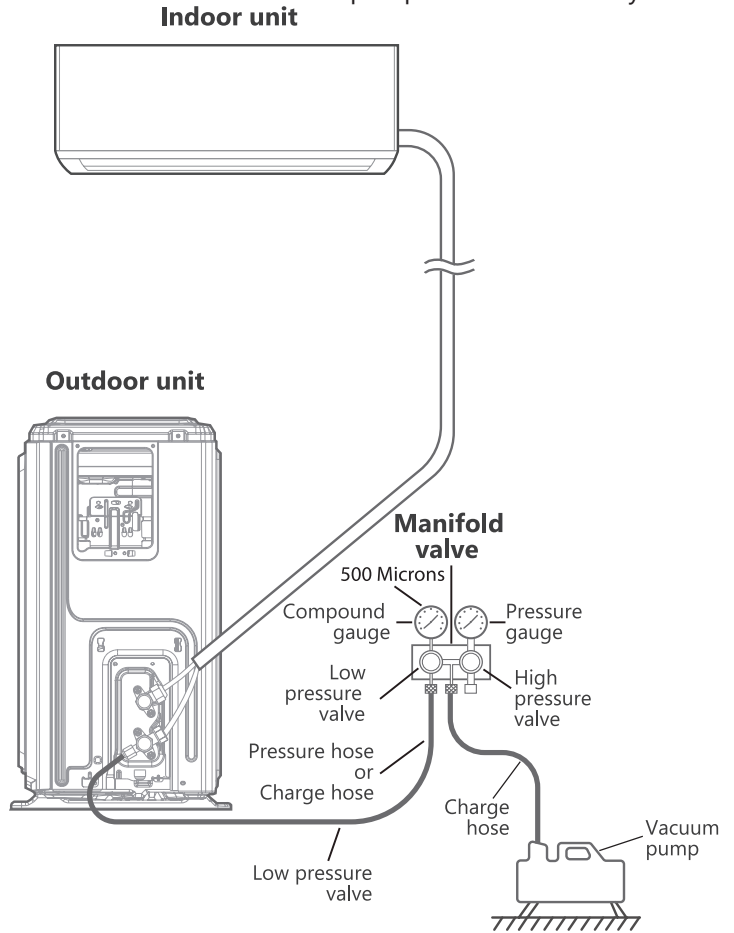
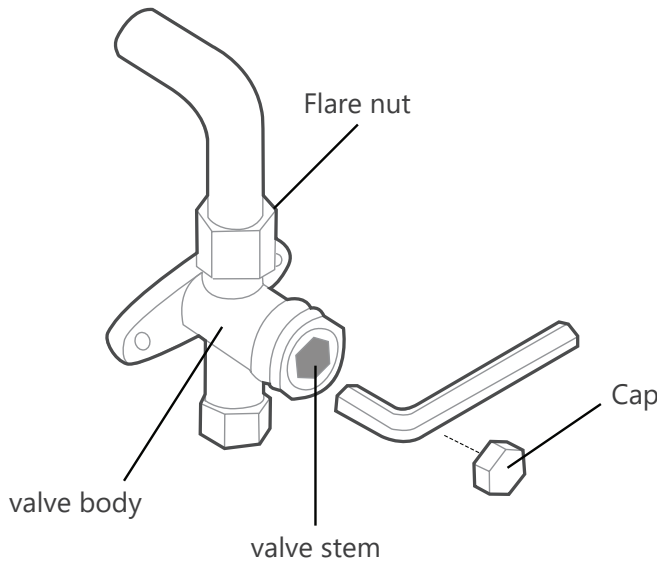


Fig. 6-1: Manifold Gauge Arrangement

6. Run the vacuum for at least 15 minutes, or until the Compound Meter reads 500 microns.
7. Close the Low-Pressure side of the manifold gauge and turn off the vacuum pump.
8. Wait for 5 minutes, then check that there has been no change in system pressure.
9. If there is a change in system pressure, refer to the Gas Leak Check section for information on how to check for leaks. If there is no change in system pressure, unscrew the cap from the packed valve (high-pressure valve).
10. Insert a hexagonal wrench into the packed valve (high-pressure valve) and open the valve by turning the wrench in a 1/4 counterclockwise turn. Listen for gas to exit the system, then close the valve after 5 seconds.
11. Watch the Pressure Gauge for one minute to make sure that there is no change in pressure. The Pressure Gauge should read slightly higher than atmospheric pressure.

12. Remove the charge hose from the service port.



**Fig. 6-2: Service Valve**

13. Using a hexagonal wrench, fully open both the high-pressure and low-pressure valves.
14. Tighten all valve caps hand-tight plus one flat to ensure no leaks. You may tighten it further using a torque wrench if needed.

**CAUTION**

**NOTE ON ADDING REFRIGERANT**  
**DO NOT** mix refrigerant types.

Some systems require additional charging depending on pipe lengths. In North America, the standard pipe length is 25 ft. (7.5 m). The refrigerant should be charged from the service port on the outdoor unit's low-pressure valve. The additional refrigerant to be charged can be calculated using the following formula:

**Table 6-1: Additional Refrigerant Formula**

Connective Pipe	Air Purging Method	Additional Refrigerant	
≤ Standard pipe length		N/A	
> Standard pipe length	Vacuum Pump	Liquid Side: Ø 1/4 in. (Ø 6.35 mm) R454B: (Pipe length – standard length) x 15 g/m (Pipe length – standard length) x 0.16 oz./ft.	Liquid Side: Ø 3/8 in. (Ø 9.52 mm) R454B: (Pipe length – standard length) x 30 g/m (Pipe length – standard length) x 0.32 oz./ft.

## Step 7 - Electrical & Gas Leak Checks

**WARNING**

**RISK OF ELECTRIC SHOCK**

ALL WIRING MUST COMPLY WITH LOCAL AND NATIONAL ELECTRICAL CODES AND MUST BE INSTALLED BY A LICENSED ELECTRICIAN.

**WARNING**

**BEFORE CHECKING THE SYSTEM**

Only perform test run after you have completed the following steps:

- Electrical Safety Checks – Confirm that the unit's electrical system is safe and operating properly.
- Gas Leak Checks – Check all flare nut connections and confirm that the system is not leaking.
- Confirm that gas and liquid (high and low pressure) valves are fully open.

**ELECTRICAL SAFETY CHECKS**

After installation, confirm that all electrical wiring is installed in accordance with local and national regulations, and according to the Installation Manual.

**BEFORE TEST RUN**

**Check Grounding Work**

Measure grounding resistance by visual detection and with a grounding resistance tester.

**DURING TEST RUN**

**Check for Electrical Leakage**

During the Test Run, use an electro probe and multimeter to perform a comprehensive electrical leakage test.

If electrical leakage is detected, turn off the unit immediately and call a licensed electrician to find and resolve the cause of the leakage.

**NOTE**

This may not be required for some locations in North America.

**GAS LEAK CHECKS**

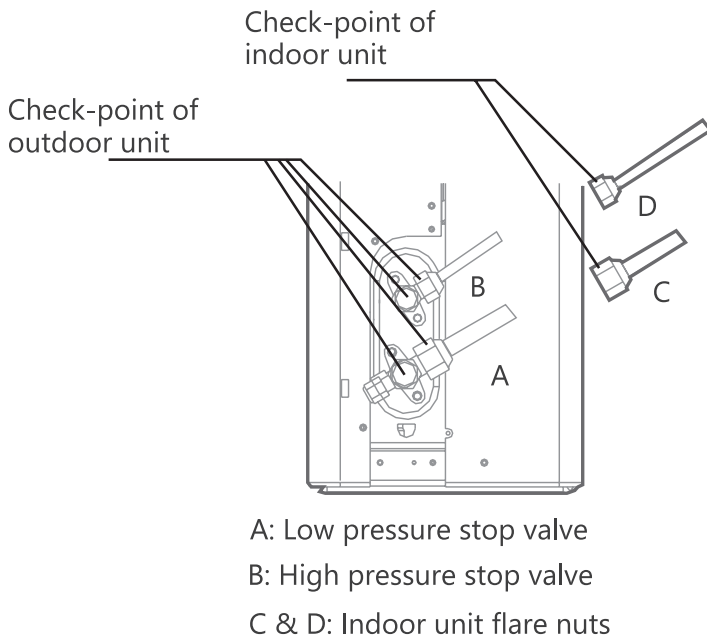
There are two different methods to check for gas leaks.

**Soap and Water Method**

Using a soft brush, apply soapy water or liquid detergent to all pipe connection points on the indoor unit and outdoor unit. The presence of bubbles indicates a leak.

**Leak Detector Method**

If using leak detector, refer to the device's operation manual for proper usage instructions.



**Fig. 7-1: Indoor and Outdoor Checkpoints**

**AFTER PERFORMING GAS LEAK CHECKS**

After confirming that all pipe connection points **DO NOT** leak, replace the valve cover on the outside unit.

## Step 8 - Test Run

### Test run Instructions

You should perform the **Test Run** for at least 30 minutes.

1. Connect power to the unit.
2. Press the **ON/OFF** button on the remote controller to turn it on..
3. Press the **MODE** button to scroll through the following functions, one at a time:
  - a. **COOL**–Select lowest possible temperature
  - b. **HEAT**–Select highest possible temperature
3. Let each function run for 5 minutes, and perform the following checks:

**Table 8-1: Test Run Check List**

List of Check to Perform	PASS?	FAIL?
No electrical leakage		
Unit is properly grounded		
All electrical terminals properly covered		
Indoor and outdoor units are solidly installed		
All pipe connection points do not leak <b>Outdoor (2 each):</b> <b>Indoor (2 each):</b>		
Water drains properly from drain hose		
All piping is properly insulated		
Unit performs COOL function properly		
Unit performs HEAT function properly		
Indoor unit louvers rotate properly		
Indoor unit responds to remote controller		

### DOUBLE-CHECK PIPE CONNECTIONS

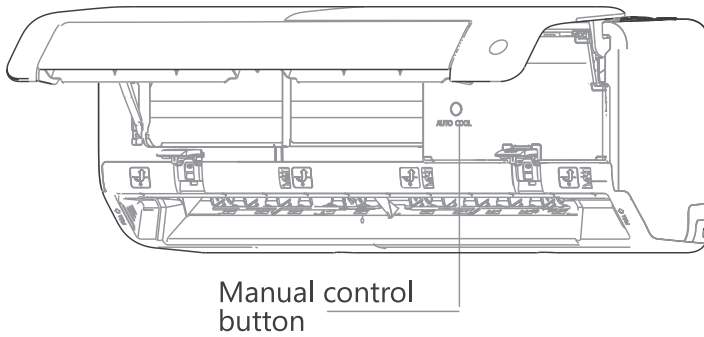
During operation, the pressure of the refrigerant circuit will increase. This may reveal leaks that were not present during your initial leak check. Take time during the Test Run to double-check that all refrigerant pipe connection points do not have leaks. Refer to Step 7 - Electrical & Gas Leak Checks section for instructions.

5. After the Test Run is successfully completed, and you confirm that all checks points in List of Checks to Perform have **PASSED**, do the following:
  - a. Using the remote control, return unit to normal operating temperature.
  - b. Using insulation tape, wrap the indoor refrigerant pipe connections that you left uncovered during the indoor unit installation process.

### IF AMBIENT TEMPERATURE IS BELOW 60°F (16°C)

You cannot use the remote controller to turn on the **COOL** function when the ambient temperature is below 60°F. In this instance, you can use the **MANUAL CONTROL** button to test the **COOL** function.

1. Lift the front panel of the indoor unit and raise it until it clicks in place.
2. The **MANUAL CONTROL** button is located on the right-hand side of the unit. Press it 2 times to select the **COOL** function.
3. Perform Test Run as normal.



**Fig. 8-1: Manual Control Button Location**

**NOTE**

The constant airflow volume motor is applied. So, the airflow volume is constant at all ESP within the stated range.

## Trademarks Copyrights & Legal Statement

Midea logo, word marks, trade name, trade dress, and all versions thereof are valuable assets of Midea Group and/or its affiliates (“Midea”), to which Midea owns trademarks, copyrights, and other intellectual property rights, and all goodwill derived from using any part of a Midea trademark. Use of Midea trademark for commercial purposes without the prior written consent of Midea may constitute trademark infringement or unfair competition in violation of relevant laws.

This manual is created by Midea and Midea reserves all copyrights thereof. No entity or individual may use, duplicate, modify, distribute in whole or in part this manual, or bundle or sell with other products without the prior written consent of Midea.

All the functions and instructions described were up to date at the time of printing this manual. However, the actual product may vary due to improved functions and designs.

## Disposal and Recycling

This symbol indicates that this product shall not be disposed of with other household waste at the end of its service life. Used devices must be returned to an official collection point for recycling of electrical electronic devices. To find these collection systems please contact your local authorities or retailer where the product was purchased. Each household performs an important role in recovering and recycling old appliances. Appropriate disposal of used appliances helps prevent potential negative consequences for the environment and human health.



## Data Protection Notice

For the provision of the services agreed with the customer, we agree to comply without restriction with all stipulations of applicable data protection law, in line with agreed countries within which services to the customer will be delivered, as well as, where applicable.

Generally, our data processing is to fulfill our obligation under contract with you and for product safety reasons, to safeguard your rights in connection with warranty and product registration questions. In some cases, but only if appropriate data protection is ensured, personal data might be transferred to recipients located outside of the European Economic Area.

Further information is provided upon request. You can contact our Data Protection **MideaDPO@midea.com**. To exercise your rights such as the right to object to your personal data being processed for direct marketing purposes, please contact us via **MideaDPO@midea.com**. To find further information, please follow the QR Code.



## **Important!**

### **Product Warranty Information**

The Warranty Registration below is a requirement to print a warranty certificate. You're not mandated to register your products to enjoy the Midea Standard Warranty; however, registration is highly recommended. Registering your warranty within 60 days ensures easy access to support and service when needed.

The design and specifications may change without prior notice in order to enhance the product. For detailed information, please consult your sales agency or the manufacturer. Any updates to the manual will be posted on the service website, so be sure to check for the latest version.

#### **United States**



<https://www.mideacomfort.us/registration.html>

#### **Canada**



<https://www.mideacomfortna.ca/registration.html>